

**Lidar Toolbox™**

User's Guide



**MATLAB®**

R2022a



# How to Contact MathWorks



Latest news: [www.mathworks.com](http://www.mathworks.com)  
Sales and services: [www.mathworks.com/sales\\_and\\_services](http://www.mathworks.com/sales_and_services)  
User community: [www.mathworks.com/matlabcentral](http://www.mathworks.com/matlabcentral)  
Technical support: [www.mathworks.com/support/contact\\_us](http://www.mathworks.com/support/contact_us)



Phone: 508-647-7000



The MathWorks, Inc.  
1 Apple Hill Drive  
Natick, MA 01760-2098

*Lidar Toolbox™ User's Guide*

© COPYRIGHT 2020–2022 by The MathWorks, Inc.

The software described in this document is furnished under a license agreement. The software may be used or copied only under the terms of the license agreement. No part of this manual may be photocopied or reproduced in any form without prior written consent from The MathWorks, Inc.

FEDERAL ACQUISITION: This provision applies to all acquisitions of the Program and Documentation by, for, or through the federal government of the United States. By accepting delivery of the Program or Documentation, the government hereby agrees that this software or documentation qualifies as commercial computer software or commercial computer software documentation as such terms are used or defined in FAR 12.212, DFARS Part 227.72, and DFARS 252.227-7014. Accordingly, the terms and conditions of this Agreement and only those rights specified in this Agreement, shall pertain to and govern the use, modification, reproduction, release, performance, display, and disclosure of the Program and Documentation by the federal government (or other entity acquiring for or through the federal government) and shall supersede any conflicting contractual terms or conditions. If this License fails to meet the government's needs or is inconsistent in any respect with federal procurement law, the government agrees to return the Program and Documentation, unused, to The MathWorks, Inc.

## Trademarks

MATLAB and Simulink are registered trademarks of The MathWorks, Inc. See [www.mathworks.com/trademarks](http://www.mathworks.com/trademarks) for a list of additional trademarks. Other product or brand names may be trademarks or registered trademarks of their respective holders.

## Patents

MathWorks products are protected by one or more U.S. patents. Please see [www.mathworks.com/patents](http://www.mathworks.com/patents) for more information.

## Revision History

September 2020	Online only	New for Version 1.0 (R2020b)
March 2021	Online only	Revised for Version 1.1 (R2021a)
September 2021	Online only	Revised for Version 2.0 (R2021b)
March 2022	Online only	Revised for Version 2.1 (R2022a)

## 1

### Lidar Toolbox Featured Examples

<b>Build a Map with Lidar Odometry and Mapping (LOAM) Using Unreal Engine Simulation</b> .....	<b>1-2</b>
<b>Curb Detection in 3-D Lidar Point Cloud</b> .....	<b>1-14</b>
<b>Code Generation for Lidar Object Detection Using SqueezeSegV2 Network</b> .....	<b>1-34</b>
<b>Lidar Object Detection Using Complex-YOLO v4 Network</b> .....	<b>1-40</b>
<b>Automate Ground Truth Labeling for Lidar Point Cloud Semantic Segmentation Using Lidar Labeler</b> .....	<b>1-55</b>
<b>Create, Process, and Export Digital Surface Model from Lidar Data</b> ...	<b>1-65</b>
<b>Multi-Lidar Calibration</b> .....	<b>1-73</b>
<b>Extract Forest Metrics and Individual Tree Attributes from Aerial Lidar Data</b> .....	<b>1-86</b>
<b>Code Generation For Aerial Lidar Semantic Segmentation Using PointNet ++ Deep Learning</b> .....	<b>1-95</b>
<b>Build Map and Localize Using Segment Matching</b> .....	<b>1-101</b>
<b>Lidar and Camera Calibration</b> .....	<b>1-119</b>
<b>Lidar Point Cloud Semantic Segmentation Using PointSeg Deep Learning Network</b> .....	<b>1-128</b>
<b>Detect, Classify, and Track Vehicles Using Lidar</b> .....	<b>1-139</b>
<b>Feature-Based Map Building from Lidar Data</b> .....	<b>1-154</b>
<b>Detect Vehicles in Lidar Using Image Labels</b> .....	<b>1-163</b>
<b>Lidar Point Cloud Semantic Segmentation Using SqueezeSegV2 Deep Learning Network</b> .....	<b>1-173</b>
<b>Code Generation for Lidar Point Cloud Segmentation Network</b> .....	<b>1-182</b>
<b>Lidar 3-D Object Detection Using PointPillars Deep Learning</b> .....	<b>1-189</b>

<b>Aerial Lidar SLAM Using FPFH Descriptors</b> .....	<b>1-200</b>
<b>Collision Warning Using 2-D Lidar</b> .....	<b>1-214</b>
<b>Track Vehicles Using Lidar: From Point Cloud to Track List</b> .....	<b>1-224</b>
<b>Build Map from 2-D Lidar Scans Using SLAM</b> .....	<b>1-242</b>
<b>Terrain Classification for Aerial Lidar Data</b> .....	<b>1-249</b>
<b>Data Augmentations for Lidar Object Detection Using Deep Learning</b>	<b>1-255</b>
<b>Unorganized to Organized Conversion of Point Clouds Using Spherical Projection</b> .....	<b>1-265</b>
<b>Lane Detection in 3-D Lidar Point Cloud</b> .....	<b>1-272</b>
<b>Automate Ground Truth Labeling For Vehicle Detection Using PointPillars</b> .....	<b>1-289</b>
<b>Track-Level Fusion of Radar and Lidar Data</b> .....	<b>1-299</b>
<b>Code Generation For Lidar Object Detection Using PointPillars Deep Learning</b> .....	<b>1-319</b>
<b>Aerial Lidar Semantic Segmentation Using PointNet++ Deep Learning</b> .....	<b>1-324</b>

## Lidar Labeling

# 2

<b>Get Started with the Lidar Labeler</b> .....	<b>2-2</b>
Load Lidar Data to Label .....	<b>2-2</b>
Create Labels and Attributes .....	<b>2-4</b>
Ground Segmentation .....	<b>2-6</b>
Label Point Cloud Using Automation .....	<b>2-7</b>
View and Adjust the Labels .....	<b>2-7</b>
Export the Labels .....	<b>2-10</b>
<b>Keyboard Shortcuts and Mouse Actions for Lidar Labeler</b> .....	<b>2-12</b>
Label Definitions .....	<b>2-12</b>
Frame Navigation and Time Interval Settings .....	<b>2-12</b>
Labeling Window .....	<b>2-12</b>
Cuboid Resizing and Moving .....	<b>2-13</b>
Zooming, Panning, and Rotating .....	<b>2-14</b>
App Sessions .....	<b>2-14</b>
<b>Use Custom Point Cloud Source Reader for Labeling</b> .....	<b>2-15</b>
Create Custom Reader Function .....	<b>2-15</b>
Import Data Source into Lidar Labeler App .....	<b>2-15</b>



<b>Create Automation Algorithm for Labeling</b> .....	<b>2-17</b>
Create New Algorithm .....	2-17
Import Existing Algorithm .....	2-18
Custom Algorithm Execution .....	2-18
<b>Temporal Automation Algorithms</b> .....	<b>2-21</b>
Create Temporal Automation Algorithm .....	2-21
Run Temporal Automation Algorithm .....	2-21

## Lidar Viewer Tutorial

### 3

<b>Create Custom Preprocessing Workflow with Lidar Viewer</b> .....	<b>3-2</b>
Read Point Cloud Data .....	3-2
Load Point Cloud Data into Lidar Viewer .....	3-2
Create Custom Preprocessing Algorithm .....	3-3
Combine Multiple Preprocessing Algorithms .....	3-9
Export Custom Preprocessing Workflow to MATLAB Function .....	3-10
Export Point Cloud Data from Lidar Viewer .....	3-11

## Concept Pages

### 4

<b>Introduction to Lidar</b> .....	<b>4-2</b>
What is Lidar? .....	4-2
What is a Point Cloud? .....	4-2
Types of Lidar .....	4-3
Advantages of Lidar Technology .....	4-4
Lidar Processing Overview .....	4-5
Applications of Lidar Technology .....	4-5
<b>Coordinate Systems in Lidar Toolbox</b> .....	<b>4-7</b>
World Coordinate System .....	4-7
Sensor Coordinate System .....	4-7
Spatial Coordinate System .....	4-8
Pattern Coordinate System .....	4-8
<b>What Is Lidar-Camera Calibration?</b> .....	<b>4-10</b>
Extrinsic Calibration of Lidar and Camera .....	4-10
<b>Calibration Guidelines</b> .....	<b>4-14</b>
Checkerboard Guidelines .....	4-14
Guidelines for Capturing Data .....	4-15
<b>What are Organized and Unorganized Point Clouds?</b> .....	<b>4-17</b>
Introduction .....	4-17
Unorganized to Organized Conversion .....	4-17
<b>Parameter Tuning for Ground Segmentation</b> .....	<b>4-20</b>

<b>Get Started with Lidar Camera Calibrator</b> .....	<b>4-21</b>
Load Data .....	4-21
Feature Detection .....	4-22
Calibration .....	4-27
Export Results .....	4-28
Keyboard Shortcuts and Mouse Actions .....	4-28
Limitations .....	4-30
<b>Get Started with Lidar Viewer</b> .....	<b>4-32</b>
Load Data .....	4-32
Data Visualization .....	4-34
Color Controls .....	4-37
Camera View Options .....	4-39
Edit Point Cloud .....	4-43
Custom Preprocessing Algorithms .....	4-46
Export Point Cloud .....	4-47
Measure Point Cloud .....	4-47
<b>Getting Started with PointPillars</b> .....	<b>4-49</b>
PointPillars Network .....	4-49
Create PointPillars Network .....	4-50
Transfer Learning .....	4-50
Train PointPillars Object Detector and Perform Object Detection .....	4-50
Code Generation .....	4-50
<b>Getting Started with PointNet++</b> .....	<b>4-52</b>
PointNet++ Network .....	4-52
Create PointNet++ Network .....	4-53
Train PointNet++ Network .....	4-53
Code Generation .....	4-53

## Tutorials

# 5

<b>Generate Lidar Point Cloud Data for Driving Scenario with Multiple Actors</b> .....	<b>5-2</b>
<b>Read Point Cloud Data from LAZ File</b> .....	<b>5-6</b>
<b>Estimate Transformation Between Two Point Clouds Using Features</b> .....	<b>5-7</b>
<b>Match and Visualize Corresponding Features in Point Clouds</b> .....	<b>5-10</b>
<b>Read Lidar and Camera Data from Rosbag File</b> .....	<b>5-13</b>
<b>Read, Process, and Write Lidar Point Cloud Data</b> .....	<b>5-15</b>
<b>Extract Ground Points and Non-Ground Points From Lidar Data</b> .....	<b>5-20</b>

# Lidar Toolbox Featured Examples

---

- “Build a Map with Lidar Odometry and Mapping (LOAM) Using Unreal Engine Simulation” on page 1-2
- “Curb Detection in 3-D Lidar Point Cloud” on page 1-14
- “Code Generation for Lidar Object Detection Using SqueezeSegV2 Network” on page 1-34
- “Lidar Object Detection Using Complex-YOLO v4 Network” on page 1-40
- “Automate Ground Truth Labeling for Lidar Point Cloud Semantic Segmentation Using Lidar Labeler” on page 1-55
- “Create, Process, and Export Digital Surface Model from Lidar Data” on page 1-65
- “Multi-Lidar Calibration ” on page 1-73
- “Extract Forest Metrics and Individual Tree Attributes from Aerial Lidar Data” on page 1-86
- “Code Generation For Aerial Lidar Semantic Segmentation Using PointNet++ Deep Learning” on page 1-95
- “Build Map and Localize Using Segment Matching” on page 1-101
- “Lidar and Camera Calibration” on page 1-119
- “Lidar Point Cloud Semantic Segmentation Using PointSeg Deep Learning Network” on page 1-128
- “Detect, Classify, and Track Vehicles Using Lidar” on page 1-139
- “Feature-Based Map Building from Lidar Data” on page 1-154
- “Detect Vehicles in Lidar Using Image Labels” on page 1-163
- “Lidar Point Cloud Semantic Segmentation Using SqueezeSegV2 Deep Learning Network” on page 1-173
- “Code Generation for Lidar Point Cloud Segmentation Network” on page 1-182
- “Lidar 3-D Object Detection Using PointPillars Deep Learning” on page 1-189
- “Aerial Lidar SLAM Using FPFH Descriptors” on page 1-200
- “Collision Warning Using 2-D Lidar” on page 1-214
- “Track Vehicles Using Lidar: From Point Cloud to Track List” on page 1-224
- “Build Map from 2-D Lidar Scans Using SLAM” on page 1-242
- “Terrain Classification for Aerial Lidar Data” on page 1-249
- “Data Augmentations for Lidar Object Detection Using Deep Learning” on page 1-255
- “Unorganized to Organized Conversion of Point Clouds Using Spherical Projection” on page 1-265
- “Lane Detection in 3-D Lidar Point Cloud” on page 1-272
- “ Automate Ground Truth Labeling For Vehicle Detection Using PointPillars” on page 1-289
- “Track-Level Fusion of Radar and Lidar Data” on page 1-299
- “Code Generation For Lidar Object Detection Using PointPillars Deep Learning” on page 1-319
- “Aerial Lidar Semantic Segmentation Using PointNet++ Deep Learning” on page 1-324

## Build a Map with Lidar Odometry and Mapping (LOAM) Using Unreal Engine Simulation

This example shows how to build a map with the lidar odometry and mapping (LOAM) [1] on page 1-0 algorithm by using synthetic lidar data from the Unreal Engine® simulation environment. In this example, you learn how to:

- Record and visualize synthetic lidar sensor data from a 3D simulation environment using the Unreal Engine.
- Use the LOAM algorithm to register the recorded point clouds and build a map.

### Set Up Scenario in Simulation Environment

Load the prebuilt Large Parking Lot (Automated Driving Toolbox) scene and a preselected reference trajectory. For information on how to generate a reference trajectory interactively by selecting a sequence of waypoints, see the “Select Waypoints for Unreal Engine Simulation” (Automated Driving Toolbox) example.

```
% Load reference path
data = load("parkingLotReferenceData.mat");

% Set reference trajectory of the ego vehicle
refPosesX = data.refPosesX;
refPosesY = data.refPosesY;
refPosesT = data.refPosesT;

% Set poses of the parked vehicles
parkedPoses = data.parkedPoses;

% Display the reference trajectory and the parked vehicle locations
sceneName = "LargeParkingLot";
hScene = figure(Name="Large Parking Lot",NumberTitle="off");
helperShowSceneImage(sceneName);
hold on
plot(refPosesX(:,2),refPosesY(:,2),LineWidth=2,DisplayName="Reference Path");
scatter(parkedPoses(:,1),parkedPoses(:,2),[],"filled",DisplayName="Parked Vehicles");
xlim([-60 40])
ylim([10 60])
hScene.Position = [100 100 1000 500]; % Resize figure
title("Large Parking Lot")
legend
```



Open the Simulink® model, and add additional vehicles to the scene using the `helperAddParkedVehicle` function.

```
modelName = 'GenerateLidarDataOfParkingLot';
open_system(modelName)
snapnow
helperAddParkedVehicles(modelName, parkedPoses)
```

### Record and Visualize Data

Use the Simulation 3D Vehicle with Ground Following (Automated Driving Toolbox) block to simulate a vehicle moving along the specified reference trajectory. Use the Simulation 3D Lidar (Automated Driving Toolbox) block to mount a lidar on the center of the roof of the vehicle, and record the sensor data.

```
close(hScene)
```

```
if ~ispc
    error("Unreal Engine Simulation is supported only on Microsoft" + char(174) + " Windows" + char(174))
end
```

```
% Run simulation
simOut = sim(modelName);

close_system(modelName, 0)
```

Use the `helperGetPointClouds` on page 1-0 function and the `helperGetLidarGroundTruth` on page 1-0 function to extract the lidar data and the ground truth poses.

```
ptCloudArr = helperGetPointClouds(simOut);
groundTruthPosesLidar = helperGetLidarGroundTruth(simOut);
```

## Detect Edge Points and Surface Points

The LOAM algorithm uses edge points and surface points for registration and mapping. The `detectLOAMFeatures` function outputs a `LOAMPoints` object, which stores the selected edge points and surface points. It includes the label of each point, which can be sharp-edge, less-sharp-edge, planar-surface, or less-planar-surface. Use the `pcregisterloam` function to register two organized point clouds.

```
ptCloud = ptCloudArr(1);
nextPtCloud = ptCloudArr(2);
gridStep = 1;
tform = pcregisterloam(ptCloud,nextPtCloud,gridStep);
disp(tform)
```

rigid3d with properties:

```
Rotation: [3x3 single]
Translation: [-0.2341 0.0101 0.0041]
```

Alternatively, for more control over the trade-off between accuracy and speed, you can first detect the LOAM feature points, and then perform LOAM registration using `pcregisterloam`. These steps are recommended before LOAM registration:

- 1 Detect LOAM feature points using the `detectLOAMFeatures` function.
- 2 Downsample the less planar surface points using the `downsampleLessPlanar` object function. This step helps speed up registration using the `pcregisterloam` function.

Because the detection algorithm relies on the neighbors of each point to classify edge points and surface points, as well as to identify unreliable points on the boundaries of occluded regions, preprocessing steps like downsampling, denoising and ground removal are not recommended before feature point detection. To remove noise from data farther from the sensor, and to speed up registration, filter the point cloud by range. The `helperRangeFilter` on page 1-0 function selects a cylindrical neighborhood around the sensor, given a specified cylinder radius, and excludes data that is too close to the sensor and might include part of the vehicle.

```
egoRadius = 2;
cylinderRadius = 30;
ptCloud = helperRangeFilter(ptCloud,egoRadius,cylinderRadius);
nextPtCloud = helperRangeFilter(nextPtCloud,egoRadius,cylinderRadius);
```

```
figure
hold on
title("Cylindrical Neighborhood")
pcshow(ptCloud)
view(2)
```

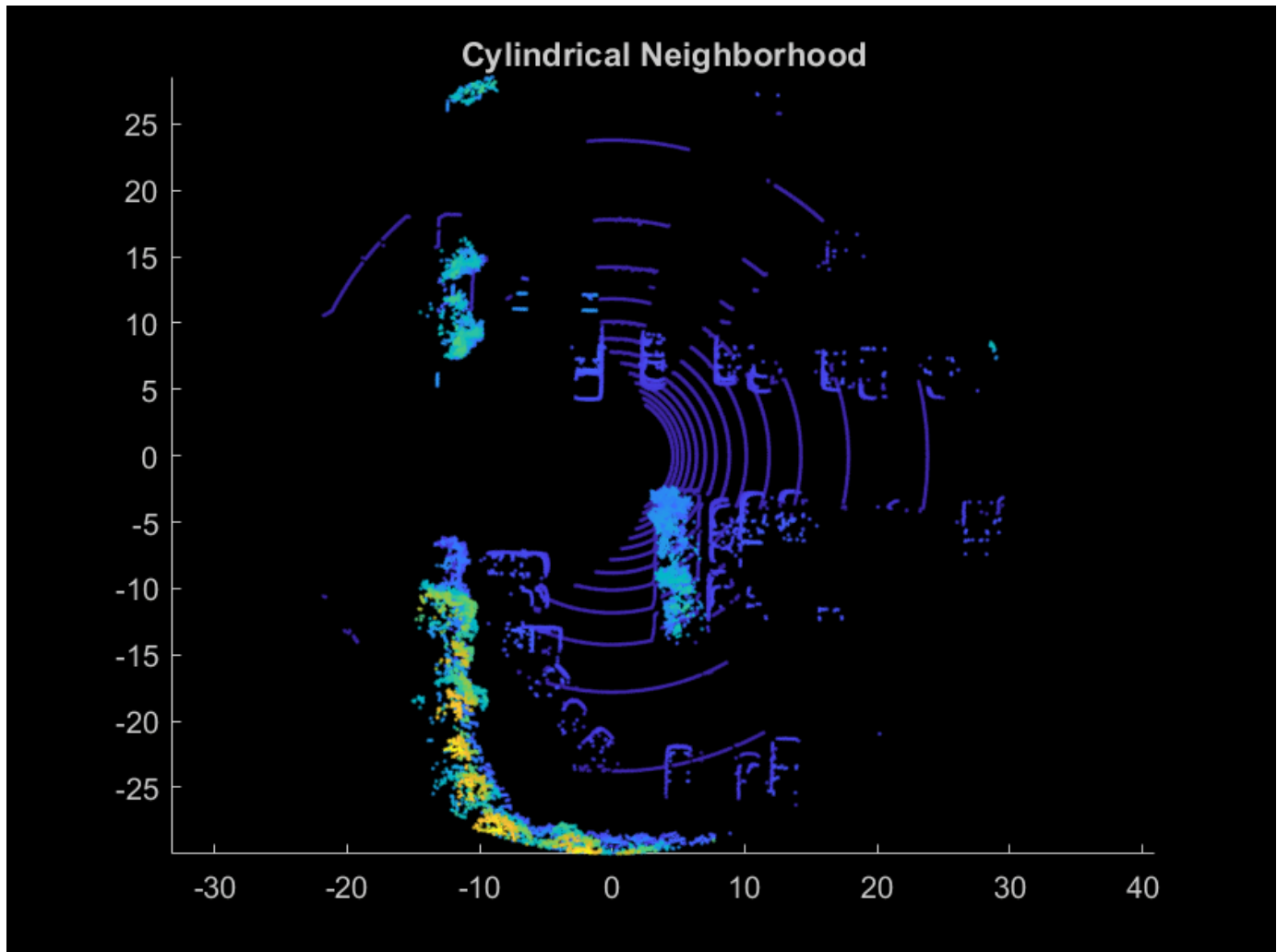

Next, detect LOAM feature points using the `detectLOAMFeatures` function. Tuning this function requires empirical analysis. The `detectLOAMFeatures` name-value arguments provide a trade-off between registration accuracy and speed. To improve the accuracy of the registration, you must minimize the root mean squared error of the Euclidean distance between the aligned points. Track and minimize the root mean squared error output `rmse` of the `pcregisterloam` function as you increase the value of the `NumRegionsPerLaser`, `MaxSharpEdgePoints`, `MaxLessSharpEdgePoints`, and `MaxPlanarSurfacePoints` arguments of `detectLOAMFeatures`.

```
maxPlanarSurfacePoints = 8;
points = detectLOAMFeatures(ptCloud,MaxPlanarSurfacePoints=maxPlanarSurfacePoints);
nextPoints = detectLOAMFeatures(nextPtCloud,MaxPlanarSurfacePoints=maxPlanarSurfacePoints);

figure
hold on
title("LOAM Points")
show(points,MarkerSize=12)
```

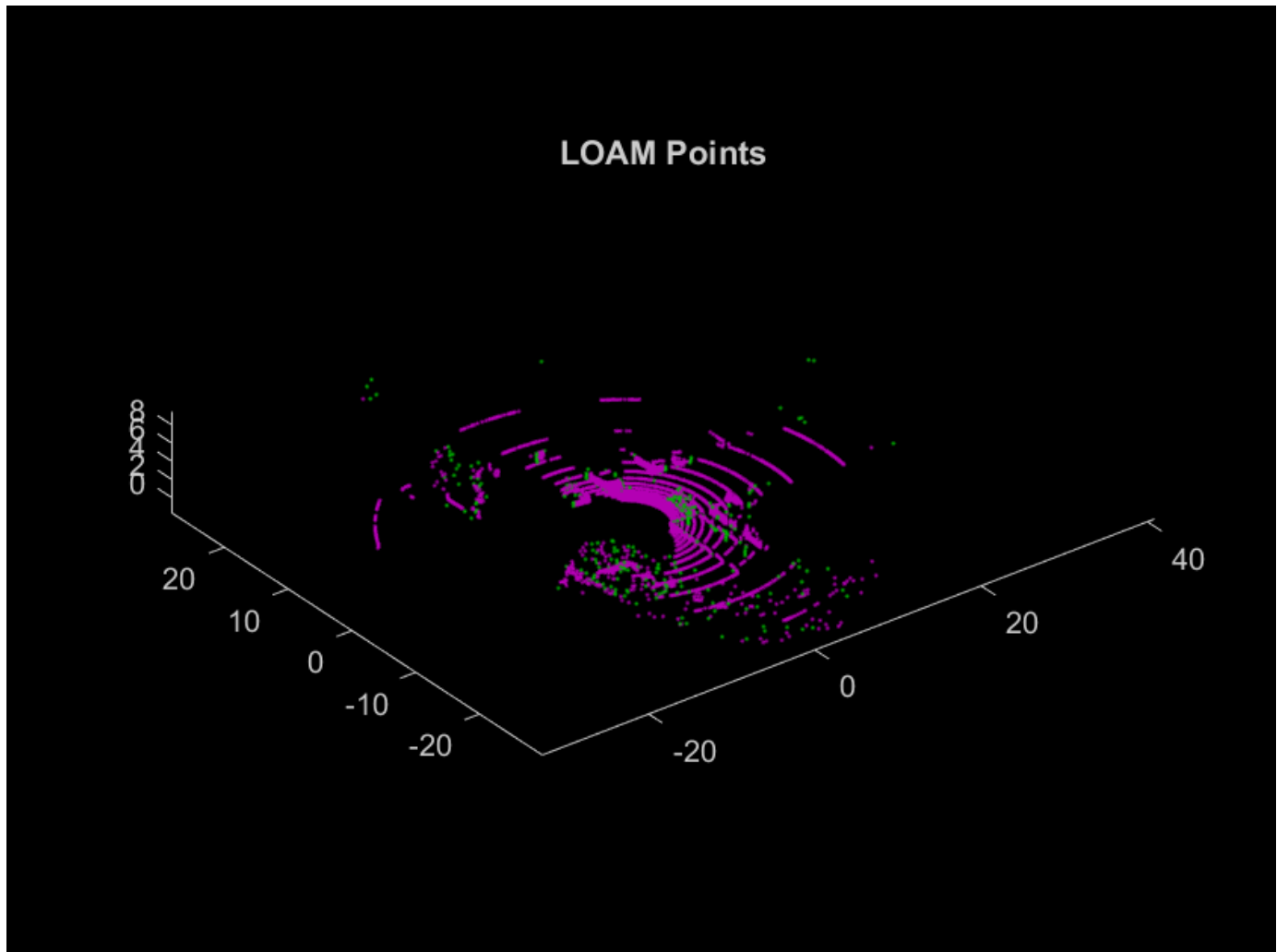

```
[~,rmse] = pcregisterloam(points,nextPoints);
disp(rmse)
```

```
0.2951
```

`detectLOAMFeatures` first identifies sharp edge points, less sharp edge points, and planar surface points. All remaining points that are not considered unreliable points, and have a curvature value below the threshold are classified as less planar surface points. Downsampling the less planar surface points can speed up registration when using `pcregisterloam`.

```
points = downsampleLessPlanar(points,gridStep);
```

```
figure
hold on
title('LOAM Points After Downsampling the Less Planar Surface Points')
show(points,'MarkerSize',12)
```



## LOAM Points After Downsampling the Less Planar Surface Points

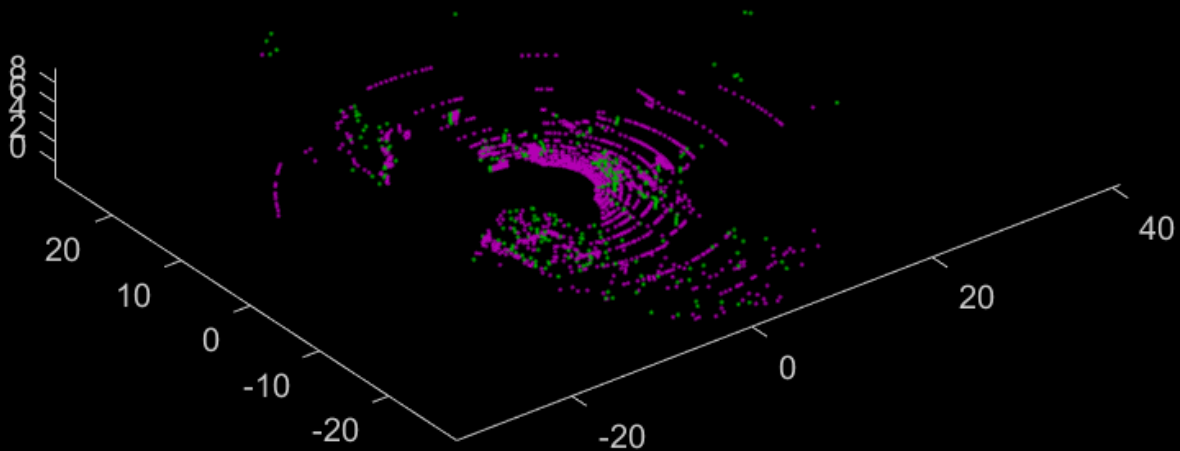

### Build Map Using Lidar Odometry

The LOAM algorithm consists of two main components that are integrated to compute an accurate transformation: Lidar Odometry and Lidar Mapping. Use the `pregisterloam` function with the one-to-one matching method to get the estimated transformation using the Lidar Odometry algorithm. The one-to-one matching method matches each point to its nearest neighbor, matching edge points to edge points and surface points to surface points. Use these matches to compute an estimate of the transformation. Use `pregisterloam` with the one-to-one matching method to incrementally build a map of the parking lot. Use a `pcviewset` object to manage the data.

Initialize the poses and the point cloud view set.

```
absPose = groundTruthPosesLidar(1);
relPose = rigid3d;
vSetOdometry = pcviewset;
```

Add the first view to the view set.

```
viewId = 1;
vSetOdometry = addView(vSetOdometry,viewId,absPose);
```

Register the point clouds incrementally and visualize the vehicle position in the parking lot scene.

```
% Display the parking lot scene with the reference trajectory
hScene = figure(Name="Large Parking Lot",NumberTitle="off");
helperShowSceneImage(sceneName);
hold on
plot(refPosesX(:,2),refPosesY(:,2),LineWidth=2)
xlim([-60 40])
ylim([10 60])
hScene.Position = [100 100 1000 500];

numSkip = 5;
for k = (numSkip+1)+1:numSkip:numel(ptCloudArr)
    prevPoints = points;
    viewId = viewId + 1;
    ptCloud = ptCloudArr(k);

    % Apply a range filter to the point cloud
    ptCloud = helperRangeFilter(ptCloud,egoRadius,cylinderRadius);

    % Detect LOAM points and downsample the less planar surface points
    points = detectLOAMFeatures(ptCloud,MaxPlanarSurfacePoints=maxPlanarSurfacePoints);
    points = downsampleLessPlanar(points,gridStep);

    % Register the points using the previous relative pose as an initial
    % transformation
    relPose = pcregisterloam(points,prevPoints,InitialTransform=relPose);

    % Update the absolute pose and store it in the view set
    absPose = rigid3d(relPose.T * absPose.T);
    vSetOdometry = addView(vSetOdometry,viewId,absPose);

    % Visualize the absolute pose in the parking lot scene
    plot(absPose.Translation(1),absPose.Translation(2),Color="r",Marker=".",MarkerSize=8);
    xlim([-60 40])
    ylim([10 60])
    title("Build a Map Using Lidar Odometry")
    legend(["Ground Truth","Estimated Position"])
    pause(0.001)
    view(2)
end
```

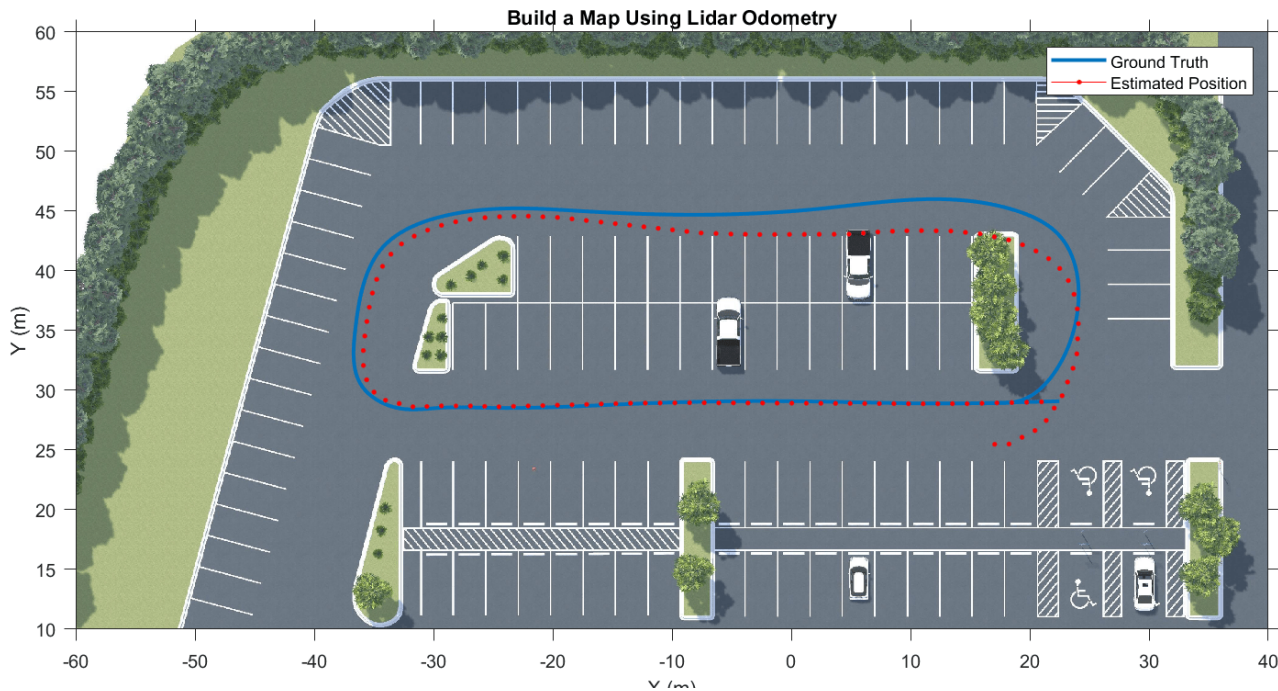

### Improve the Accuracy of the Map with Lidar Mapping

Lidar Mapping uses more points for registration and relies on a local map to find more accurate poses. Use the `pcregisterloam` function with the one-to-many matching method to get the estimated transformation using the Lidar Mapping registration algorithm. The one-to-many matching method matches each point to multiple nearest neighbors. Then, it uses these matches to compute the transformation. You can use the one-to-many matching method of Lidar Mapping to refine the rough estimate from the one-to-one matching method of Lidar Odometry. Lidar Mapping registers against a local map that contains points from multiple laser scans. Using this matching method, there are more points available to compute the transformation using the one-to-many matching method. Use the `helperLidarMap` object to manage the points in the map and select a local map for registration using the `selectLocalMap` object function of `helperLidarMap`.

Initialize the poses.

```
absPose = groundTruthPosesLidar(1);
relPose = rigid3d;
vSetMapping = pcviewset;
```

Detect LOAM points in the first point cloud.

```
ptCloud = ptCloudArr(1);
ptCloud = helperRangeFilter(ptCloud, egoRadius, cylinderRadius);
points = detectLOAMFeatures(ptCloud, 'MaxPlanarSurfacePoints', maxPlanarSurfacePoints);
points = downsampleLessPlanar(points, gridStep);
```

Add the first view to the view set.

```
viewId = 1;
vSetMapping = addView(vSetMapping, viewId, absPose);
```

Create a map using the `helperLidarMap` class, and add points to the map using the `addPoints` object function of `helperLidarMap`.

```
lidarMap = helperLidarMap;  
lidarMap = addPoints(lidarMap, points, absPose);
```

Select a local map using the `selectLocalMap` object function of `helperLidarMap`.

```
sz = [50 50 100];  
lidarMap = selectLocalMap(lidarMap, absPose.Translation, sz);
```

Use `pregisterloam` with the one-to-one matching method to get an estimated pose using Lidar Odometry. Then, use `pregisterloam` with the points in the local map and the one-to-many matching method to refine this pose. Get the points in the local map for registration using the `getLocalMap` object function of `helperLidarMap`. The `getLocalMap` object function returns the points inside the local map selected using `selectLocalMap`. Downsample the points in the map using the `downsamplePoints` object function of `helperLidarMap` to remove duplicate points from the map.

```
% Display the parking lot scene with the reference trajectory  
hScene = figure(Name="Large Parking Lot", NumberTitle="off");  
helperShowSceneImage(sceneName);  
hold on  
plot(refPosesX(:,2), refPosesY(:,2), LineWidth=2)  
xlim([-60 40])  
ylim([10 60])  
hScene.Position = [100 100 1000 500];  
  
numSkip = 5;  
for k = (numSkip+1)+1:numSkip:numel(ptCloudArr)  
    prevPtCloud = ptCloud;  
    prevPoints = points;  
    viewId = viewId + 1;  
    ptCloud = ptCloudArr(k);  
  
    % Apply a range filter to the point cloud  
    ptCloud = helperRangeFilter(ptCloud, egoRadius, cylinderRadius);  
  
    % Detect LOAM points and downsample the less planar surface points  
    points = detectLOAMFeatures(ptCloud, MaxPlanarSurfacePoints=maxPlanarSurfacePoints);  
    points = downsampleLessPlanar(points, gridStep);  
  
    % Register the points using the previous relative pose as an initial  
    % transformation  
    relPose = pregisterloam(points, prevPoints, MatchingMethod="one-to-one", InitialTransform=relPose);  
  
    % Update the absolute pose  
    absPose = rigid3d(relPose.T * absPose.T);  
  
    % Get the LOAM points in the local map using the estimated absolute  
    % pose  
    mapPoints = getLocalMap(lidarMap, absPose);  
  
    % getLocalMap returns the mapPoints aligned to the last points  
    % detected. Find the refinement transformation that improves the  
    % alignment of the points  
    poseRefinement = pregisterloam(points, mapPoints, MatchingMethod="one-to-many", InitialTransform=relPose);  
  
    % Refine the absolute pose using the pose refinement transformation  
    absPose = rigid3d(poseRefinement.T * absPose.T);
```

```

% Store the refined absolute pose in the view set
vSetMapping = addView(vSetMapping,viewId,absPose);

% Add the new points to the map
lidarMap = addPoints(lidarMap,points,absPose);

% Downsample the map to remove duplicate points
lidarMap = downsamplePoints(lidarMap,0.5);

% Select a new local map using the new absolute pose
lidarMap = selectLocalMap(lidarMap,absPose.Translation,sz);

% Visualize the absolute pose in the parking lot scene
plot(absPose.Translation(1),absPose.Translation(2),Color="r",Marker=".",MarkerSize=8)
xlim([-60 40])
ylim([10 60])
title("Build a Map Using Lidar Mapping")
legend(["Ground Truth","Estimated Position"])
pause(0.001)
view(2)
end

```



### Compare Results

Visualize the estimated trajectories and compare them to the ground truth. Notice that combining Lidar Odometry and Lidar Mapping results in a more accurate map.

```

figure
plot(refPosesX(:,2),refPosesY(:,2),LineWidth=2,DisplayName="Ground Truth")
hold on

```

```

% Get the positions estimated with Lidar Odometry
odometryPositions = vertcat(vSetOdometry.Views.AbsolutePose.Translation);

```

```

plot(odometryPositions(:,1),odometryPositions(:,2),LineWidth=2,DisplayName="Odometry")

% Get the positions estimated with Lidar Odometry and Mapping
mappingPositions = vertcat(vSetMapping.Views.AbsolutePose.Translation);
plot(mappingPositions(:,1),mappingPositions(:,2),LineWidth=2,DisplayName="Odometry and Mapping")

legend
title("Compare Trajectories")

```

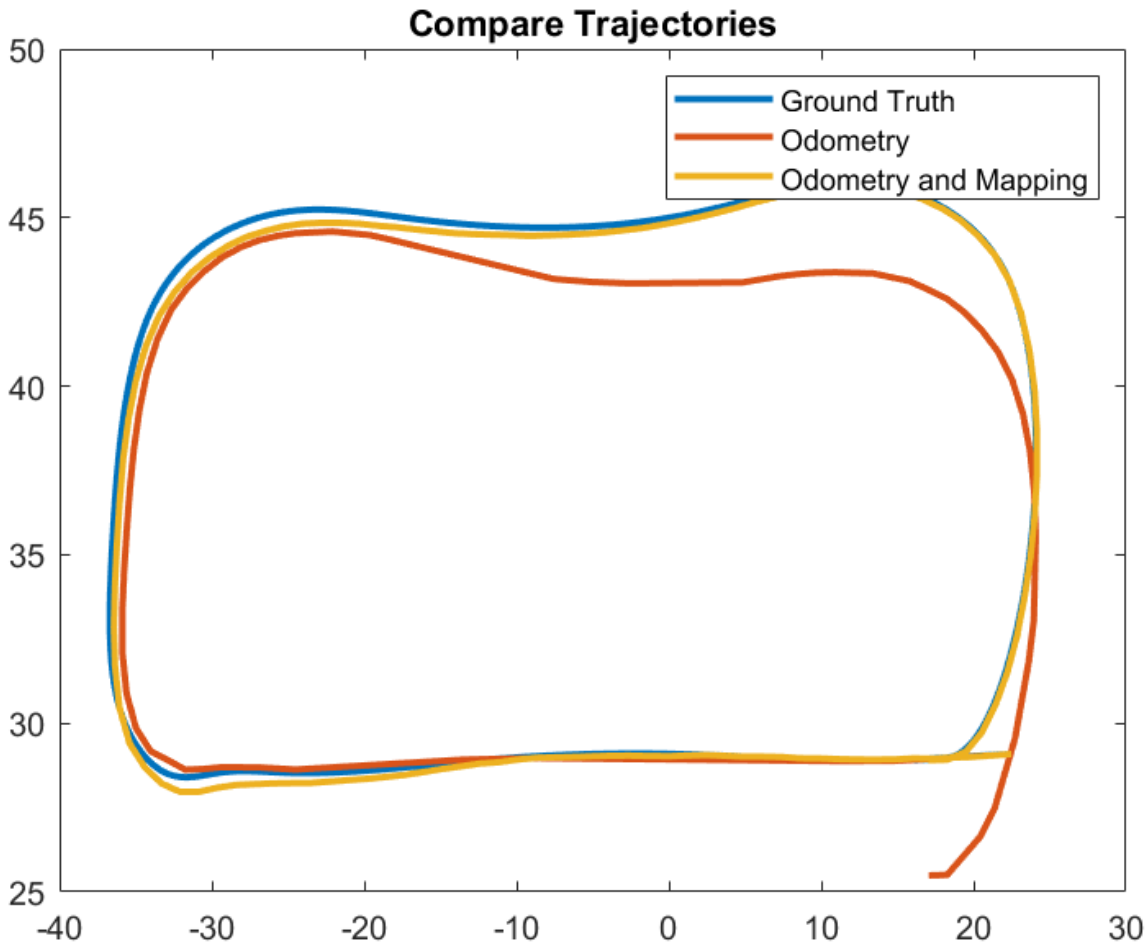

## References

[1] Zhang, Ji, and Sanjiv Singh. "LOAM: Lidar Odometry and Mapping in Real-Time." In *Robotics: Science and Systems X*. Robotics: Science and Systems Foundation, 2014. <https://doi.org/10.15607/RSS.2014.X.007>.

## Supporting Functions

**helperGetPointClouds** extracts an array of pointCloud objects that contain lidar sensor data.

```
function ptCloudArr = helperGetPointClouds(simOut)
```

```

% Extract signal
ptCloudData = simOut.ptCloudData.signals.values;

% Create a pointCloud array
ptCloudArr = pointCloud(ptCloudData(:,:,,2)); % Ignore first frame
for n = 3:size(ptCloudData,4)
    ptCloudArr(end+1) = pointCloud(ptCloudData(:,:,,n)); %#ok<AGROW>
end

end

```

**helperGetLidarGroundTruth** extracts an array of rigid3d objects that contain the ground truth location and orientation.

```

function gTruth = helperGetLidarGroundTruth(simOut)

numFrames = size(simOut.lidarLocation.time,1);
gTruth = repmat(rigid3d,numFrames-1,1);

for i = 2:numFrames
    gTruth(i-1).Translation = squeeze(simOut.lidarLocation.signals.values(:,:,i));
    % Ignore the roll and the pitch rotations since the ground is flat
    yaw = double(simOut.lidarOrientation.signals.values(:,3,i));
    gTruth(i-1).Rotation = [cos(yaw) sin(yaw) 0;
                           -sin(yaw) cos(yaw) 0;
                           0 0 1];
end

end

```

**helperRangeFilter** filters the point cloud by range.

```

function ptCloud = helperRangeFilter(ptCloud,egoRadius,cylinderRadius)

% Compute the distance between each point and the origin
dists = hypot(ptCloud.Location(:,:,1),ptCloud.Location(:,:,2));

% Select the points inside the cylinder radius and outside the ego radius
cylinderIdx = dists <= cylinderRadius & dists >= egoRadius;
ptCloud = select(ptCloud,cylinderIdx,OutputSize="full");

end

```



## Curb Detection in 3-D Lidar Point Cloud

This example shows how to detect curbs in lidar point clouds. A *curb* is a line of stone or concrete, that connects the roadway to the sidewalk. Curbs act as delimiters for the drivable area of the road. In the absence of GPS signals, detecting the curb position is important for path planning and safe navigation in autonomous driving applications.

This example uses a subset of the PandaSet data set from Hesai and Scale. The PandaSet contains lidar point cloud scans of various city scenes captured using the Pandar64 sensor.

### Introduction

Curb detection in lidar point cloud involves the detecting the left and right curbs of a road with respect to the ego vehicle. The lidar sensor is mounted on the top of the vehicle.

Use these steps to detect curbs in the point cloud data captured by the lidar sensor:

- 1 Extract a region of interest(ROI)
- 2 Classify on-road and off-road points
- 3 Identify the road shape using the off-road points
- 4 Detect candidate curb points using the on-road points

### Download Lidar Data Set

The size of the data set is 5.2 GB, and it contains 2560 preprocessed organized point clouds. Out of these, this example uses a subset of 27 point clouds. Each point cloud is specified as a 64-by-1856-by-3 array. The ground truth data contains the semantic segmentation labels for 13 classes. The point clouds are stored in PCD format, and the ground truth data is stored in PNG format.

Download the PandaSet data set using the `helperDownloadPandasetData` helper function, defined at the end of this example.

```
% Set random seed to generate reproducible results
rng("default");
[ptCloudData,labelsData] = helperDownloadPandasetData;
```

Select the first frame of the data set for further processing. Visualize the point cloud.

```
ptCloud = ptCloudData{1};
labels = labelsData{1};

% Visualize the input point cloud with corresponding ground truth labels
figure
pcshow(ptCloud.Location,labels)
view(2)
title("Input Lidar Point Cloud")
```



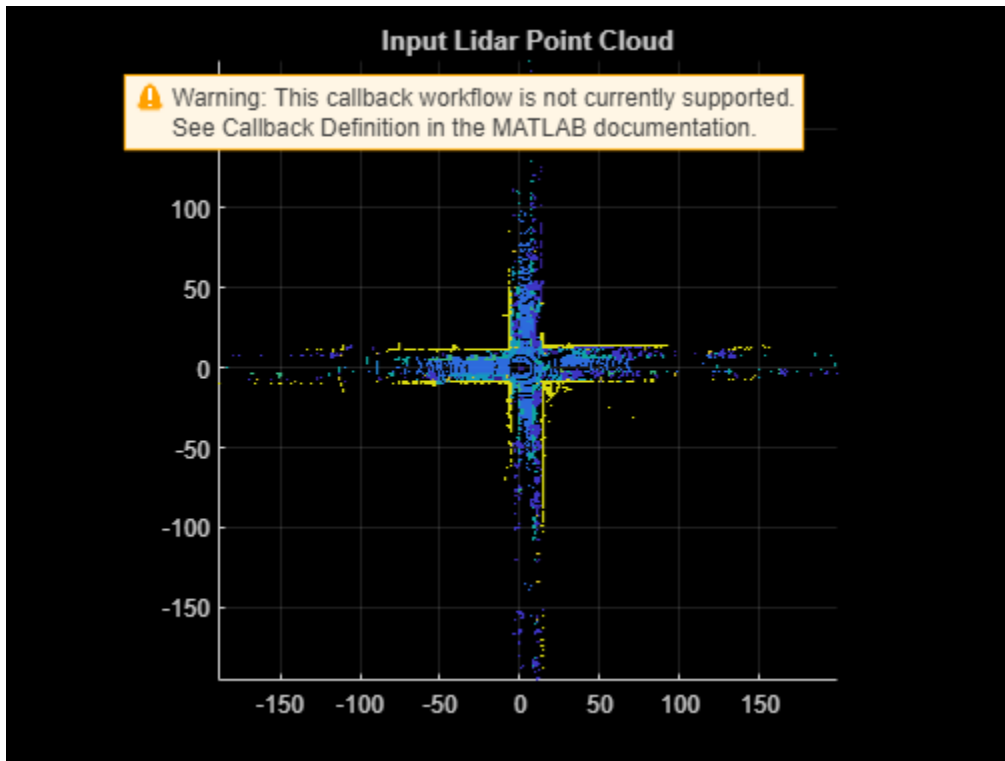

### Preprocess Data

As a preprocessing step for detecting curb points, first extract a region of interest from the point cloud and classify the points within it as on-road or off-road points.

Based on the installed position of the lidar sensor, the point cloud data is sparse beyond a certain distance. To ensure the point cloud you extract is dense enough for further processing, specify an ROI within a limited distance of the sensor.

```
% Define ROI in meters
xLim = [-35 20];
yLim = [-25 25];

roiIdx = ptCloud.Location(:,:,1) >= xLim(1) & ...
    ptCloud.Location(:,:,1) <= xLim(2) & ...
    ptCloud.Location(:,:,2) >= yLim(1) & ...
    ptCloud.Location(:,:,2) <= yLim(2);
```

Classify the point cloud into on-road and off-road points using these labels:

- 1 — Unlabeled
- 2 — Vegetation
- 3 — Ground
- 4 — Road
- 5 — Road Marking
- 6 — Side Walk
- 7 — Car

- 8 — Truck
- 9 — Other Vehicle
- 10 — Pedestrian
- 11 — Road Barrier
- 12 — Signs
- 13 — Buildings

```
labels(~roiIdx) = nan;
% The on-road points consist of ground, road and sidewalk
onRoadLabelsIdx = (labels == 3 | labels == 4 | labels == 6);

% The off-road points consist of buildings and other objects
offRoadLabelsIdx = (labels == 2 | labels == 11 | ...
    labels == 12 | labels == 13);

% Visualize the point cloud, along with on-road and off-road points.
figure
subplot(1,3,1)
pcshow(select(ptCloud,roiIdx))
view(2)
title("Cropped Input Point Cloud")

subplot(1,3,2)
pcshow(select(ptCloud,onRoadLabelsIdx))
view(2)
title("On-road Point Cloud")

subplot(1,3,3)
pcshow(select(ptCloud,offRoadLabelsIdx))
view(2)
title("Off-road Point Cloud")
```

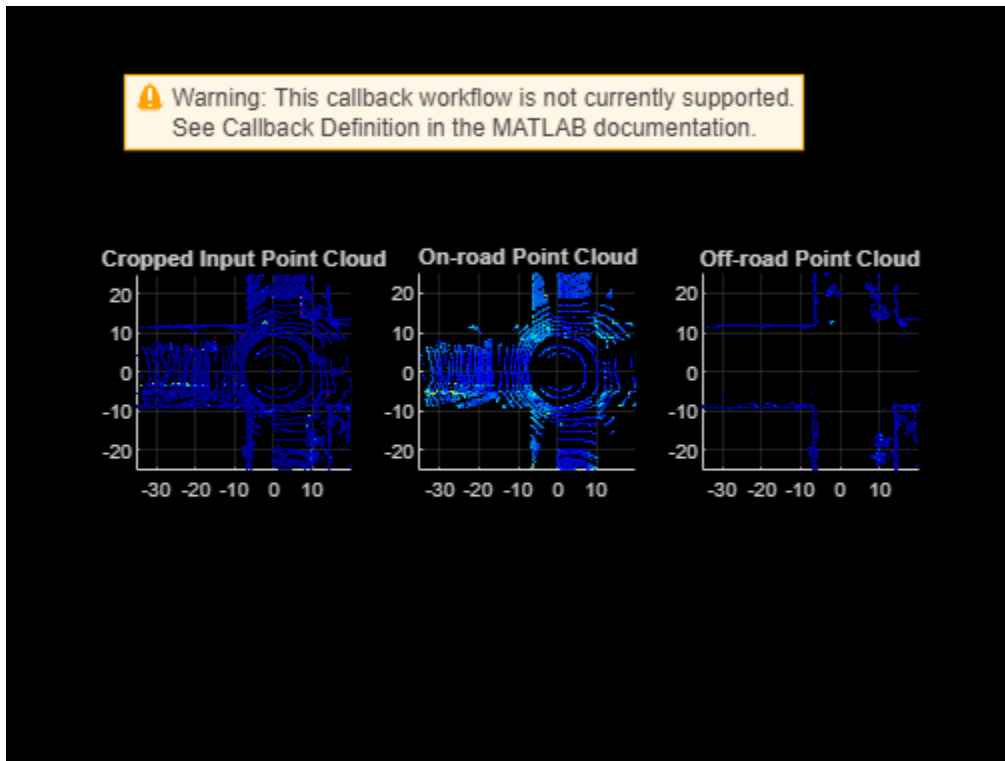

If semantic labels are not available with your data set, you can compute them using a deep learning network. For more information, see the “Lidar Point Cloud Semantic Segmentation Using SqueezeSegV2 Deep Learning Network” on page 1-173 example.

### Detect Road Shape

Apply the beam model to the off-road points to detect the road shape. For more information about the beam model, see [1] on page 1-0 and [2] on page 1-0 .

- 1 Launch a sequence of beams from a launching point. In this example, the launching point is the location of the lidar sensor on the ego vehicle.
- 2 Divide the beams into beam zones according to the angular resolution of the sensor. In this example, the angular resolution is 1 degree.
- 3 Determine the beam angles and beam lengths with respect to the launching point.
- 4 For each beam zone, determine the distance between the launching point and closest point in that zone and the distance between the launching point and the farthest point in that zone.
- 5 Compute the normalized beam length of a beam zone as the ratio of the shortest and longest distance between the launching point and a point in that zone.
- 6 Apply a customized version of the toe-finding algorithm [3] on page 1-0 to the normalized beam lengths to find the road shape.
- 7 The center angle of each toe slice is the road segmentation angle with respect to the launching point.

```
% Select the off-road point cloud
offRoadPtCloud = select(ptCloud,offRoadLabelsIdx);
```

```
% Use the helperRoadSegmentationAngles helper function defined at the end
```

```

% of this example to compute the road segmentation angles
[dk,roadAngles] = helperRoadSegmentationAngles(offRoadPtCloud);
roadAngles = sort(roadAngles);
roadAngles(end+1) = roadAngles(1);

% Visualize the off-road points and the toe slices indicating the road shape
figure
subplot(1,2,1)
pcshow(offRoadPtCloud,BackgroundColor=[1 1 1])
view(2)
title("Off-Road Point Cloud")
subplot(1,2,2)
polarplot(dk)
title("Road Shape")

```

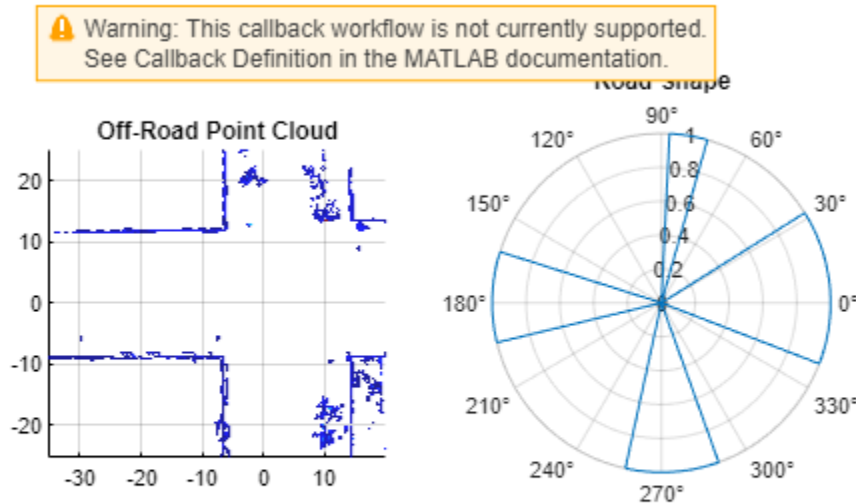

### Detect Road Curbs

Extract the feature curb points from the on-road points. Process each scan line of the on-road point cloud individually to extract the points satisfying the threshold on these features:

- **Smoothness Feature** [2] on page 1-0 — This feature checks for the smoothness of the area around a point. A higher smoothness value indicates that the point is an edge point, and a lower values indicates that the point is a plane point. Use the points with smoothness value greater than the specified smoothness threshold for further computation.
- **Height Difference Feature** [2] on page 1-0 — This feature checks for the standard deviation and the maximum difference of height around a point. Use the points with these values within the specified bounds for further computation.
- **Horizontal and Vertical Continuity Feature** [1] on page 1-0 — This feature checks for the horizontal and vertical continuity of a point with respect to its immediate neighboring points. Use

the points with horizontal and vertical distances greater than the specified threshold for further computation.

```
% Set up the parameters for detecting the curbs
numScanLines = 64;
numNeighborsOnEachSide = 5;

% Define the threshold for the smoothness feature
smoothnessThreshold = 0.001;

% Define the thresholds for the height difference feature (in meters)
heightThreshold.heightMin = 0.02;
heightThreshold.heightMax = 0.25;
heightThreshold.heightSDMin = 0.02;
heightThreshold.heightSDMax = 0.07;

% Define the threshold for the horizontal and vertical continuity feature
% (in degrees)
angleResolutionThreshold = 0.24;

ptInfluence = -2*numNeighborsOnEachSide;

Apply the height difference, smoothness, and horizontal and vertical continuity feature thresholds to
the on-road points.

% Use the helperDetectFeatureCurbs helper function defined at the
% end of this example to detect the feature curb points
[featureCurbPoints,validSmoothnessIndices,validHeightDifferenceIndices, ...
    validHorizontalVerticalContinuityIndices] = helperDetectFeatureCurbs( ...
    onRoadLabelsIdx,numScanLines,ptCloud,numNeighborsOnEachSide, ...
    ptInfluence,smoothnessThreshold,heightThreshold,angleResolutionThreshold);
```

Visualize the detected features.

```
figure
subplot(2,2,1)
pcshow(select(ptCloud,onRoadLabelsIdx & ...
    validSmoothnessIndices))
view(2)
title("Smoothness Feature")

subplot(2,2,2)
pcshow(select(ptCloud,onRoadLabelsIdx & ...
    validHeightDifferenceIndices))
view(2)
title("Height Difference Feature")

subplot(2,2,3)
pcshow(select(ptCloud,onRoadLabelsIdx & ...
    validHorizontalVerticalContinuityIndices))
view(2)
title("Horizontal and Vertical Continuity Feature")

subplot(2,2,4)
pcshow(featureCurbPoints)
view(2)
title("Feature Curb Points")
```

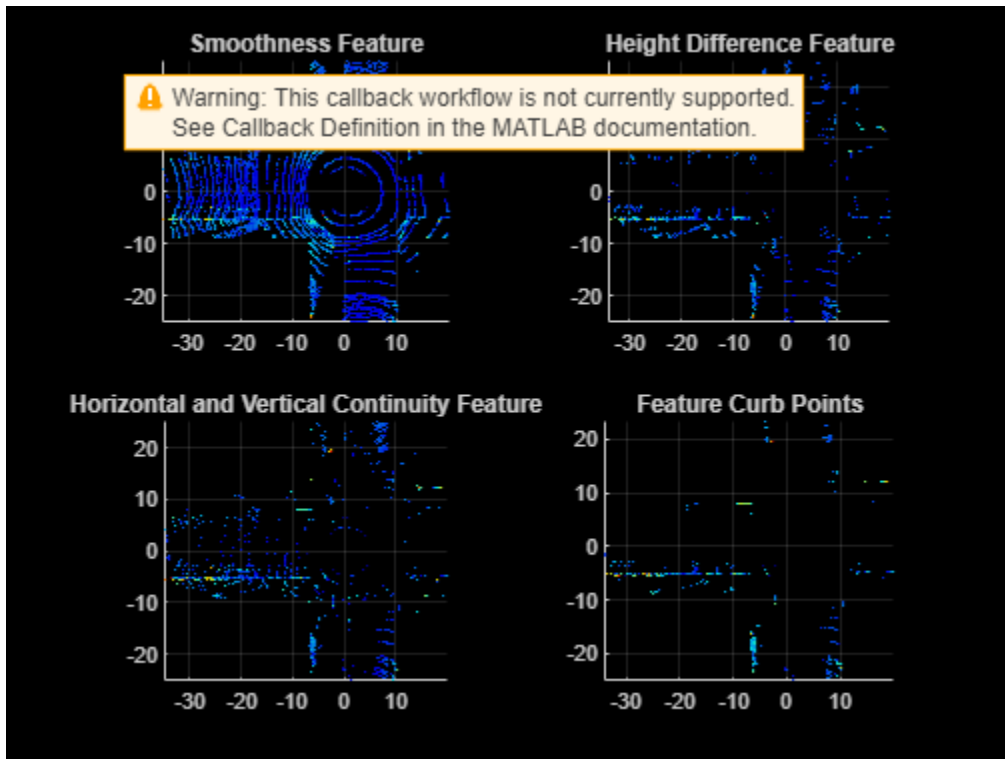

Next, compute the candidate curb points from the feature curb points:

- 1 Classify the feature curb points into different segments based on the road segmentation angles.
- 2 In each segment, define the points closest to the road segmentation lines as seed points. These seed points can be noisy and contain false positive points.
- 3 To improve the results, and to compute the candidate curb points, parabolically model the seed curbs in each segment, and use the RANSAC algorithm to remove the false positives that do not match the parabolic model.

```
% Define the threshold for RANSAC based filtering
maxDistance = 0.1;

% Define the segment size to find the seed curb points along the road
% segmentation lines
stepSegment = 0.1;

% Define the length of the road segmentation lines to search for the seed
% curb points
roadLength = hypot(diff(featureCurbPoints.XLimits),diff(featureCurbPoints.YLimits))/2;

% Use the helperDetectCandidateCurbs helper function, attached to this
% example as a supporting file, to compute the candidate curb points from
% the feature curb points
candidateCurbPoints = helperDetectCandidateCurbs(roadLength,roadAngles, ...
    featureCurbPoints,stepSegment,maxDistance);

% Visualize the point cloud overlaid with the candidate curb points
figure
pcshow(select(ptCloud,roiIdx).Location,"w")
```

```

view(2)
hold on
pcshow(candidateCurbPoints,"r",MarkerSize=200)
view(2)
hold off
title("Candidate Curb Points Detected")

```

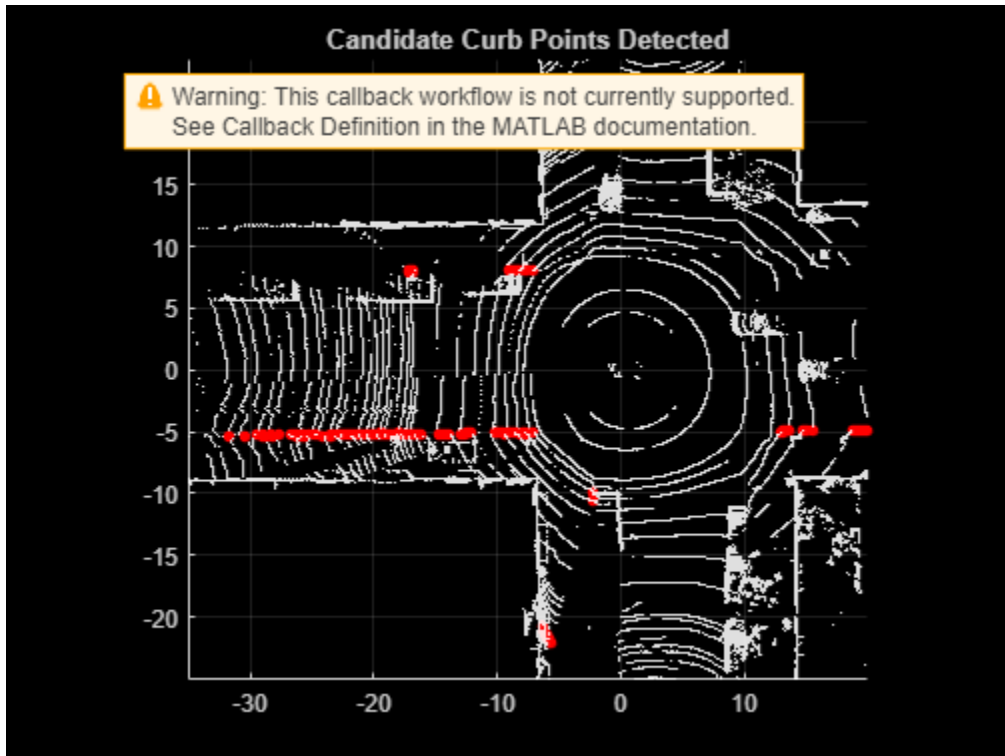

### Track Curb Points

Loop through and process the lidar data to extract and track the candidate curb points. Tracking curb points improves the robustness of curb detection. You can halt the curb tracking at the segmented roads, and restart it when the ego vehicle leaves the segmented roads. Curb tracking involves polynomial fitting on the XY-points using a 2-degree polynomial represented as  $y = ax^2 + bx + c$ , where  $a$ ,  $b$ , and  $c$  are the polynomial parameters. Curb tracking is a two-step process:

- 1 Track curb polynomial parameters  $a$  and  $b$  to control the curvature of the polynomial.
- 2 Track curb polynomial parameter  $c$  to control the drift of the polynomial.

Update these parameters by using a Kalman filter with a constant acceleration motion model. Use the `configureKalmanFilter` function to initialize a Kalman filter.

```
player = pcplayer([-35 20],[-25 25],[-10 10],MarkerSize=6);
```

```

% Initial values for Kalman filter
initParams.initialEstimateError = [1 1 1]*1e-1;
initParams.motionNoise = [1 1 1]*1e-7;
initParams.measurementNoise = 10;

```

```
leftTracker.drift = [];
```

```
leftTracker.filteredDrift = [];  
leftTracker.curveSmoothness = [];  
leftTracker.filteredCurveSmoothness = [];  
  
rightTracker.drift = [];  
rightTracker.filteredDrift = [];  
rightTracker.curveSmoothness = [];  
rightTracker.filteredCurveSmoothness = [];  
  
isTracking = false;  
isLeftCurbTrackingInitialised = false;  
isRightCurbTrackingInitialised = false;  
isPrevAngleSet = false;  
  
for fileIdx = 1:numel(ptCloudData)  
    % Load the point cloud and it's ground truth labels  
    ptCloud = ptCloudData{fileIdx};  
    labels = labelsData{fileIdx};  
  
    % Find the points lying within ROI  
    xLim = [-35 20];  
    yLim = [-25 25];  
    roiIdx = ptCloud.Location(:,:,1) >= xLim(1) & ...  
            ptCloud.Location(:,:,1) <= xLim(2) & ...  
            ptCloud.Location(:,:,2) >= yLim(1) & ...  
            ptCloud.Location(:,:,2) <= yLim(2);  
  
    labels(~roiIdx) = nan;  
  
    % Classify the points into on-road points and off-road points  
    onRoadLabelsIdx = (labels == 3 | labels == 4 | labels == 6);  
    offRoadLabelsIdx = (labels == 2 | labels == 11 | labels == 12 | ...  
                      labels == 13);  
    offRoadPtCloud = select(ptCloud,offRoadLabelsIdx);  
  
    % Compute the road segmentation angles using off-road points  
    [dk,roadAngles] = helperRoadSegmentationAngles(offRoadPtCloud);  
    if ~isempty(roadAngles)  
        roadAngles = sort(roadAngles);  
        roadAngles(end+1) = roadAngles(1);  
        if ~isPrevAngleSet && numel(roadAngles) == 3  
            prevAngle = roadAngles;  
            isPrevAngleSet = true;  
        end  
    end  
  
    % Compute number of road segments in front and behind the  
    % ego vehicle  
    numFrontRoadSegments = sum(roadAngles(1:end-1) < 95 | ...  
                              roadAngles(1:end-1) > 270);  
    numRearRoadSegments = sum(~(roadAngles(1:end-1) < 95 | ...  
                              roadAngles(1:end-1) > 270));  
  
    % Check if curb tracking should be enabled or disabled  
    if ~isTracking  
        if (numFrontRoadSegments < numRearRoadSegments) || ...  
           (numel(roadAngles) == 3)  
            isTracking = true;  
        end  
    end  
end
```



```

    end
else
    if numFrontRoadSegments > numRearRoadSegments
        isTracking = false;
        isLeftCurbTrackingInitialised = false;
        isRightCurbTrackingInitialised = false;
        isPrevAngleSet = false;
    end
    if numel(roadAngles) < 3 && isPrevAngleSet
        roadAngles = prevAngle;
    end
end
prevAngle = roadAngles;

% Compute the candidate curb points using on-road points
featureCurbPoints = helperDetectFeatureCurbs(onRoadLabelsIdx, ...
    numScanLines,ptCloud,numNeighborsOnEachSide,ptInfluence, ...
    smoothnessThreshold,heightThreshold,angleResolutionThreshold);

roadLength = hypot(diff(featureCurbPoints.XLimits), ...
    diff(featureCurbPoints.YLimits))/2;

candidateCurbPoints = helperDetectCandidateCurbs(roadLength, ...
    roadAngles,featureCurbPoints,stepSegment,maxDistance);
if isempty(candidateCurbPoints)
    continue;
end

% Divide the candidate curb points into front and rear curb points
% based on the ego vehicle position
frontCandidateCurbPoints = candidateCurbPoints( ...
    candidateCurbPoints(:,1) >= 0,:);
rearCandidateCurbPoints = candidateCurbPoints( ...
    candidateCurbPoints(:,1) < 0,:);

xVal = linspace(min(frontCandidateCurbPoints(:,1)),xLim(2),80);
if isTracking
    leftCurb = [];
    rightCurb = [];

    model = pcfplane(select(ptCloud,onRoadLabelsIdx),0.1, ...
        [0 0 1]);
    modelParams = model.Parameters;

    candidateAngles = atan2d(frontCandidateCurbPoints(:,2), ...
        frontCandidateCurbPoints(:,1));
    candidateAngles(candidateAngles < 0) = candidateAngles( ...
        candidateAngles < 0) + 360;

% Divide the candidate curb points, into left and right curb points
if (roadAngles(1) >= 270 || roadAngles(1) < 90) && ...
    (roadAngles(2) >= 90 && roadAngles(2) < 270)
    idx = candidateAngles >= roadAngles(1) & ...
        candidateAngles < roadAngles(2);
else
    idx = candidateAngles >= roadAngles(2) | ...
        candidateAngles < roadAngles(1);
end
end

```

```
leftCandidateCurbPoints = frontCandidateCurbPoints(idx,:);
rightCandidateCurbPoints = frontCandidateCurbPoints(~idx,:);

% Compute polynomials to track left and right curbs
leftPolynomial = fitPolynomialRANSAC( ...
    leftCandidateCurbPoints(:,1:2),2,0.1);
rightPolynomial = fitPolynomialRANSAC( ...
    rightCandidateCurbPoints(:,1:2),2,0.1);

if ~isempty(leftPolynomial)
    if ~isLeftCurbTrackingInitialised
        [leftFilter,leftCurb] = helperTrackCandidateCurbs( ...
            leftPolynomial,xVal,modelParams,initParams);
        isLeftCurbTrackingInitialised = true;
    else
        [leftPolynomial,leftCurb,leftTracker] = helperTrackCandidateCurbs( ...
            leftPolynomial,xVal,modelParams, ...
            leftFilter,leftTracker);
    end
end
if ~isempty(rightPolynomial)
    if ~isRightCurbTrackingInitialised
        [rightFilter,rightCurb] = helperTrackCandidateCurbs( ...
            rightPolynomial,xVal,modelParams,initParams);
        isRightCurbTrackingInitialised = true;
    else
        [rightPolynomial,rightCurb,rightTracker] = helperTrackCandidateCurbs( ...
            rightPolynomial,xVal,modelParams, ...
            rightFilter,rightTracker);
    end
end
ptCloud = select(ptCloud,roiIdx);

% Use the helperVisualiseOutput helper function, attached to this
% example as a supporting file to visualise the final output
outputPtCloud = helperVisualiseOutput(ptCloud,leftCurb,rightCurb, ...
    rearCandidateCurbPoints);
else
    ptCloud = select(ptCloud,roiIdx);

% Use the helperVisualiseOutput helper function, attached to this
% example as a supporting file to visualise the final output
outputPtCloud = helperVisualiseOutput(ptCloud,candidateCurbPoints);
end
if isOpen(player)
    view(player,outputPtCloud);
    view(player.Axes,[0 90])
    camva(player.Axes,0)
end
end
```

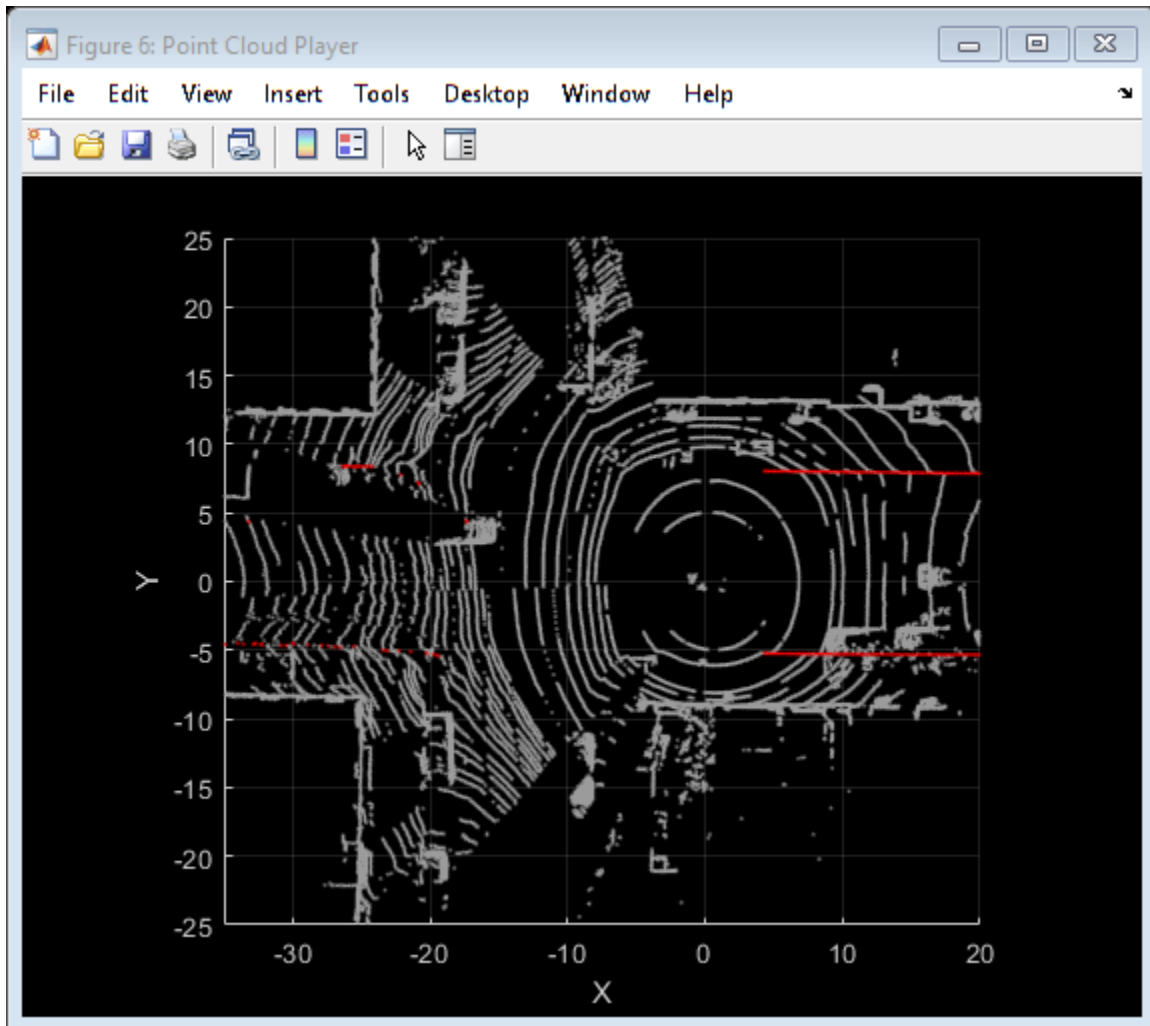

## Results

To analyze the curb detection results, compare them against the tracked curb polynomials by plotting them in figures. Each plot compares the parameters with and without the Kalman filter. The first figure compares the drift of curbs along the y-axis, and the second figure compares the smoothness of the curb polynomials. *Smoothness* is the rate of change of the slope of the curb curve.

```
figure
ax = subplot(2,1,1);
plot(leftTracker.drift)
hold on
plot(leftTracker.filteredDrift)
hold off
title("Left Curb Drift Along Y-axis")
ax.Position(2) = ax.Position(2) - 0.08;
ax = subplot(2,1,2);
plot(rightTracker.drift)
hold on
plot(rightTracker.filteredDrift)
hold off
title("Right Curb Drift Along Y-axis")
```

```
ax.Position(2) = ax.Position(2) - 0.06;
Lgnd = legend("Drift Values", "Filtered Drift Values", ...
    "Orientation", "Horizontal");
Lgnd.Position(1:2) = [0.29 0.9];
```

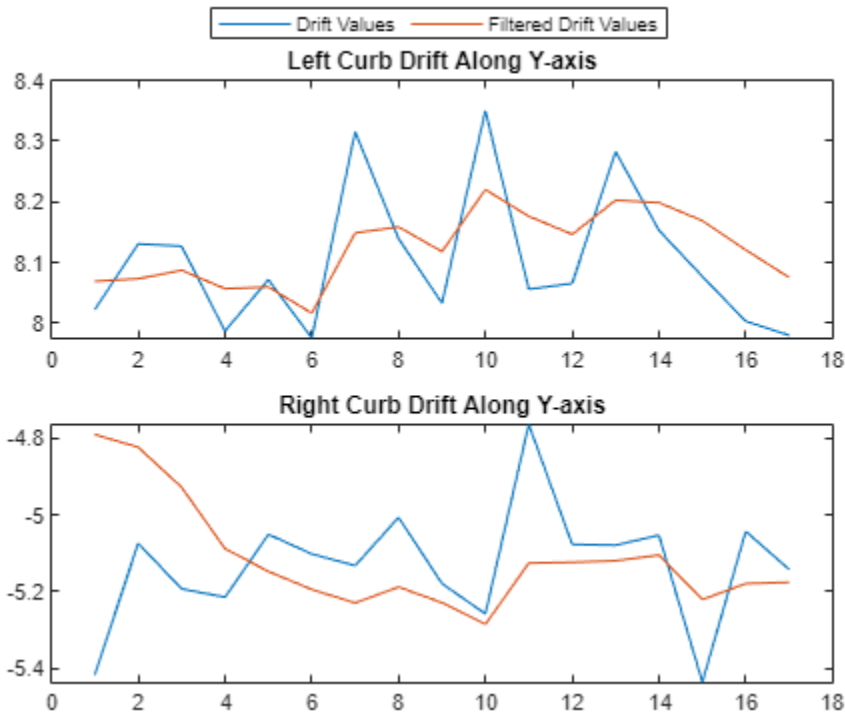

```
figure
ax = subplot(2,1,1);
plot(leftTracker.curveSmoothness);
hold on
plot(leftTracker.filteredCurveSmoothness)
hold off
title("Left Curve Smoothness")
ax.Position(2) = ax.Position(2) - 0.08;
ax = subplot(2,1,2);
plot(rightTracker.curveSmoothness);
hold on
plot(rightTracker.filteredCurveSmoothness)
hold off
title("Right Curve Smoothness")
ax.Position(2) = ax.Position(2) - 0.06;
Lgnd = legend("Curve Smoothness", "Filtered Curve Smoothness", ...
    "Orientation", "Horizontal");
Lgnd.Position(1:2) = [0.23 0.9];
```

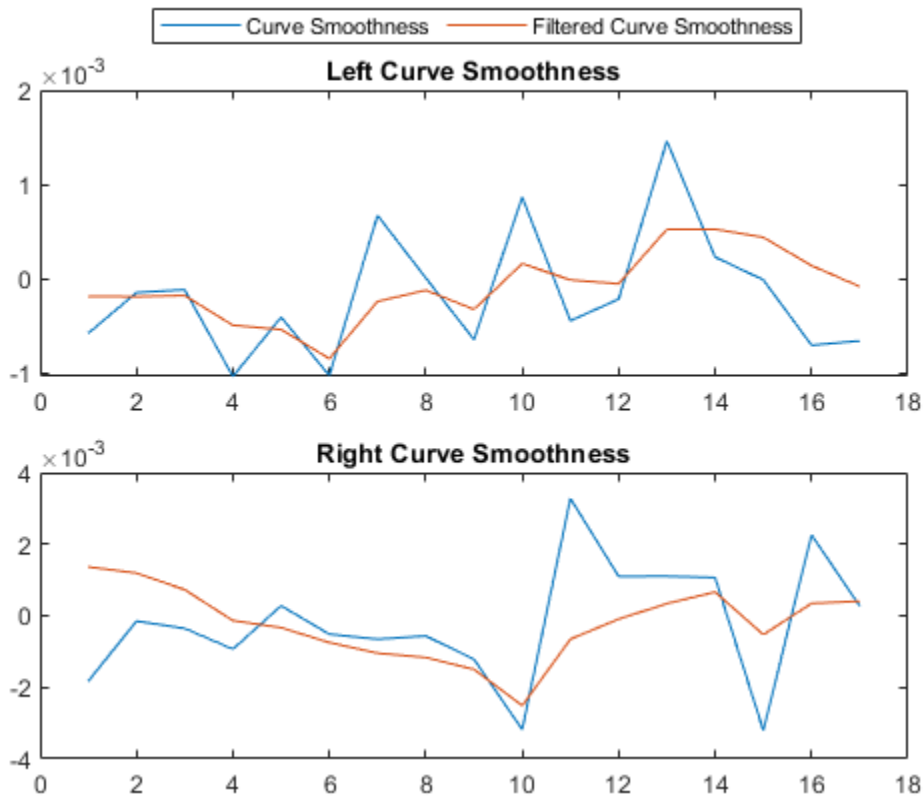

## Helper Functions

The helperDownloadPandasetData helper function loads the lidar data set into the MATLAB workspace.

```
function [ptCloudData,labelsData] = helperDownloadPandasetData()
lidarDataTarFile = matlab.internal.examples.downloadSupportFile("lidar", ...
    "data/Pandaset_LidarData.tar.gz");
filepath = fileparts(lidarDataTarFile);
outputFolder = fullfile(filepath,"Pandaset");

% Check if tar.gz file is downloaded, but not uncompressed.
if (~exist(fullfile(outputFolder,"Lidar"),"file") ...
    &&(~exist(fullfile(outputFolder,"semanticLabels"),"file")))
    untar(lidarDataTarFile,outputFolder);
end

lidarData = fullfile(outputFolder,"Lidar");
labelsFolder = fullfile(outputFolder,"semanticLabels");

ptCloudData = cell(27,1);
labelsData = cell(27,1);
count = 1;
for fileIdx = 1041:1067
    ptCloud = pcread(fullfile(lidarData,fileIdx+".pcd"));
    % The example follows the convention that ego vehicle motion is along
    % the positive x-axis, hence, transform the point cloud
```

```

theta = -90;
rot = [cosd(theta) sind(theta) 0; ...
      -sind(theta) cosd(theta) 0; ...
       0           0           1];
trans = [0 0 0];
tform = rigid3d(rot,trans);
ptCloud = pctransform(ptCloud,tform);
ptCloudData{count} = ptCloud;
labelsData{count} = imread(fullfile(labelsFolder,fileIdx+".png"));
count = count + 1;
end
end

```

The helperRoadSegmentationAngles helper function returns the road segmentation angles.

```

function [dk,angles] = helperRoadSegmentationAngles(offRoadPtCloud)
% Compute the angles of all the points in the off-road point cloud with
% respect to the launching point (origin)
roadAngles = atan2d(offRoadPtCloud.Location(:,2), ...
                   offRoadPtCloud.Location(:,1));
roadAngles(roadAngles < 0) = roadAngles(roadAngles < 0) + 360;
idx = floor(roadAngles);

minBeamLength = ones(360,1);
maxBeamLength = ones(360,1);
for k = 1:360
    % Use the points in the kth zone to compute the normalized beam length
    zonePtsIdx = idx >= (k-1) & idx < k;
    if any(zonePtsIdx)
        % Shortest distance between the zone points and the launching point
        minBeamLength(k) = min(hypot( ...
                                offRoadPtCloud.Location(zonePtsIdx,1), ...
                                offRoadPtCloud.Location(zonePtsIdx,2)));

        % Longest distance between the zone points and the launching point
        maxBeamLength(k) = max(hypot( ...
                                offRoadPtCloud.Location(zonePtsIdx,1), ...
                                offRoadPtCloud.Location(zonePtsIdx,2)));
    end
end
% Compute the normalized beam length
dk = minBeamLength./maxBeamLength;
dk(dk < 0.25) = 0;
dk(dk < mean(dk)) = 0;

peaksStart = find(diff(dk == 1) == 1) + 1;
peaksEnd = find(diff(dk == 1) == -1);

% Find indices of peaks to be merged
idx = (peaksStart - peaksEnd) < 15;
peaksStart(idx) = [];
peaksEnd(idx) = [];
if isempty(peaksStart) || isempty(peaksEnd)
    angles = [];
else
    if peaksStart(1) ~= 1
        peaksStart = [1; peaksStart];
    end
end

```

```

if peaksEnd(end) ~= 360
    peaksEnd = [peaksEnd; 360];
end
peaks = [peaksStart peaksEnd];

% Remove the outliers in peaks computation
peaks(diff(peaks,[],2) <= 3,:) = [];

% Compute the road segmentation angles from the peaks
angles = mean(peaks,2);
if abs(angles(1) + angles(end) - 360) > 0 && ...
    abs(angles(1) + angles(end) - 360) < 20
    angles(1) = angles(1) + angles(end);
    if angles(1) > 360
        angles(1) = angles(1) - 360;
    end
    angles(end) = [];
end

% Update the peaks information
dk = zeros(360,1);
for i = 1:size(peaks,1)
    dk(peaks(i,1):peaks(i,2)) = 1;
end
end
end

```

The helperCheckSmoothness helper function returns the indices of points satisfying the smoothnessThreshold condition.

```

function isSmoothnessValid = helperCheckSmoothness(neighborPtCloud, ...
    currentPt,ptInfluence,numNeighborsOnEachSide,smoothnessThreshold)
isSmoothnessValid = false(size(neighborPtCloud,1),1);

diffX = ptInfluence*currentPt(:,1) + sum(neighborPtCloud(:,1,:),3);
diffY = ptInfluence*currentPt(:,2) + sum(neighborPtCloud(:,2,:),3);
diffZ = ptInfluence*currentPt(:,3) + sum(neighborPtCloud(:,3,:),3);
numerator = vecnorm([diffX diffY diffZ]');
denominator = numNeighborsOnEachSide*vecnorm(currentPt)';

isSmoothnessValid(numerator./denominator > smoothnessThreshold) = true;
end

```

The helperCheckHeightDifference helper function returns the indices of points satisfying the heightThreshold conditions.

```

function isHeightDifferenceValid = helperCheckHeightDifference( ...
    neighborPtCloud,heightThreshold)
isHeightDifferenceValid = false(size(neighborPtCloud,1),1);

heightDifference = max(squeeze(neighborPtCloud(:,3,:)),[],2) - ...
    min(squeeze(neighborPtCloud(:,3,:)),[],2);
heightStdDev = std(squeeze(neighborPtCloud(:,3,:)),0,2);

isHeightDifferenceValid( ...
    heightStdDev > heightThreshold.heightSDMin & ...
    heightStdDev <= heightThreshold.heightSDMax & ...
    heightDifference >= heightThreshold.heightMin & ...

```

```

    heightDifference <= heightThreshold.heightMax) = true;
end

```

The helperCheckHorizontalVerticalContinuity helper function returns the indices of points satisfying the horizontalContinuityThreshold and verticalContinuityThreshold conditions.

```

function isHorizontalVerticalContinuityValid = helperCheckHorizontalVerticalContinuity( ...
    leftPt,currentPt,rightPt,angleResolutionThreshold)
isHorizontalVerticalContinuityValid = false(size(currentPt,1),1);

verticalAngle = atan2d(currentPt(:,3),hypot(currentPt(:,1), ...
    currentPt(:,2)));
horizontalContinuityThreshold = hypot(currentPt(:,1),currentPt(:,2))* ...
    angleResolutionThreshold*(pi/180);
verticalContinuityThreshold = horizontalContinuityThreshold.* ...
    sind(verticalAngle);

distanceLeftHorizontal = sqrt(sum((currentPt(:,1:2) - leftPt(:,1:2)).^2,2));
distanceRightHorizontal = sqrt(sum((currentPt(:,1:2) - rightPt(:,1:2)).^2,2));

distanceLeftVertical = abs(currentPt(:,3) - leftPt(:,3));
distanceRightVertical = abs(currentPt(:,3) - rightPt(:,3));

isHorizontalVerticalContinuityValid(distanceLeftHorizontal >= ...
    horizontalContinuityThreshold & ...
    distanceRightHorizontal >= horizontalContinuityThreshold & ...
    distanceLeftVertical >= verticalContinuityThreshold & ...
    distanceRightVertical >= verticalContinuityThreshold) = true;
end

```

The helperDetectFeatureCurbs helper function detects the feature curb points from the on-road points.

```

function [featureCurbPoints,validSmoothnessIndices, ...
    validHeightDifferenceIndices, ...
    validHorizontalVerticalContinuityIndices] = helperDetectFeatureCurbs( ...
    onRoadLabelsIdx,numScanLines,ptCloud,numNeighborsOnEachSide, ...
    ptInfluence,smoothnessThreshold,heightThreshold,angleResolutionThreshold)

% Declare and initialise the variables to store the indices of the points
% satisfying the feature thresholds
validSmoothnessIndices = false(size(onRoadLabelsIdx));
validHeightDifferenceIndices = false(size(onRoadLabelsIdx));
validHorizontalVerticalContinuityIndices = false(size(onRoadLabelsIdx));

for i = 1:numScanLines
    % Extract the points lying in a scan line
    scanLine = squeeze(ptCloud.Location(i,:,:));

    % Extract the on-road points from the scan line points
    onRoadPtsInScanLine = scanLine(onRoadLabelsIdx(i,:,:));
    validPoints = find(onRoadLabelsIdx(i,:));

    if size(onRoadPtsInScanLine,1) >= 2*numNeighborsOnEachSide + 1

        leftPoints = nan(size(onRoadPtsInScanLine,1),3, ...
            numNeighborsOnEachSide);

```



```

rightPoints = nan(size(onRoadPtsInScanLine,1),3, ...
    numNeighborsOnEachSide);

onRoadPtsInScanLineCyclic = [...
    onRoadPtsInScanLine(end:-1:end-numNeighborsOnEachSide+1,:);
    onRoadPtsInScanLine;
    onRoadPtsInScanLine(1:numNeighborsOnEachSide,:)];

for j = numNeighborsOnEachSide+1: ...
    size(onRoadPtsInScanLineCyclic,1)-numNeighborsOnEachSide
    % Select the left neighbor points of each point
    leftPoints(j-numNeighborsOnEachSide,:,:) = reshape( ...
        onRoadPtsInScanLineCyclic(j-numNeighborsOnEachSide:j-1,:)', ...
        1,3,numNeighborsOnEachSide);

    % Select the right neighbor points of each point
    rightPoints(j-numNeighborsOnEachSide,:,:) = reshape( ...
        onRoadPtsInScanLineCyclic(j+1:j+numNeighborsOnEachSide,:)', ...
        1,3,numNeighborsOnEachSide);
end
leftPoints(isnan(leftPoints(:,1,1)),:,:) = [];
rightPoints(isnan(rightPoints(:,1,1)),:,:) = [];

% Use the helperCheckSmoothness helper function to find the points
% satisfying the smoothness feature
validSmoothnessIndicesInScanLine = helperCheckSmoothness( ...
    cat(3,leftPoints,rightPoints),onRoadPtsInScanLine, ...
    ptInfluence,numNeighborsOnEachSide, ...
    smoothnessThreshold).*validPoints';

validSmoothnessIndices(i, ...
    validSmoothnessIndicesInScanLine( ...
    validSmoothnessIndicesInScanLine ~= 0)) = true;

% Use the helperCheckHeightDifference helper function to find the
% points satisfying the height difference feature
validHeightDifferenceIndicesInScanLine = helperCheckHeightDifference( ...
    cat(3,leftPoints,rightPoints),heightThreshold).*validPoints';

validHeightDifferenceIndices(i, ...
    validHeightDifferenceIndicesInScanLine( ...
    validHeightDifferenceIndicesInScanLine ~= 0)) = true;

% Use the helperCheckHorizontalVerticalContinuity helper function
% to find the points satisfying the horizontal and vertical
% continuity feature
validHorizontalVerticalContinuityIndicesInScanLine = ...
    helperCheckHorizontalVerticalContinuity( ...
    leftPoints(:, :, numNeighborsOnEachSide),onRoadPtsInScanLine, ...
    rightPoints(:, :, 1),angleResolutionThreshold).*validPoints';

validHorizontalVerticalContinuityIndices(i, ...
    validHorizontalVerticalContinuityIndicesInScanLine( ...
    validHorizontalVerticalContinuityIndicesInScanLine ~= 0)) = true;
end
end
featureCurbPoints = select(ptCloud,onRoadLabelsIdx & ...
    validHorizontalVerticalContinuityIndices & ...

```

```
        validSmoothnessIndices & ...  
        validHeightDifferenceIndices);  
featureCurbPoints = pcdenoise(featureCurbPoints);  
end
```

The helperTrackCandidateCurbs helper function tracks the candidate curb points using the Kalman filter.

```
function varargout = helperTrackCandidateCurbs(varargin)  
polynomial = varargin{1};  
xVal = varargin{2};  
modelParams = varargin{3};  
if numel(varargin) == 4  
    initParams = varargin{4};  
    curveInitialParameters = polynomial(1:2);  
    driftInitialParameters = polynomial(3);  
  
    % Configure Kalman filter  
    filter.curveFilter = configureKalmanFilter( ...  
        "ConstantAcceleration",curveInitialParameters, ...  
        initParams.initialEstimateError, ...  
        initParams.motionNoise, ...  
        initParams.measurementNoise);  
    filter.driftFilter = configureKalmanFilter( ...  
        "ConstantAcceleration",driftInitialParameters, ...  
        initParams.initialEstimateError, ...  
        initParams.motionNoise, ...  
        initParams.measurementNoise);  
  
    varargout{1} = filter;  
else  
    filter = varargin{4};  
    tracker = varargin{5};  
  
    predict(filter.curveFilter);  
    predict(filter.driftFilter);  
  
    tracker.drift = [tracker.drift;polynomial(3)];  
    tracker.curveSmoothness = [tracker.curveSmoothness;  
        polynomial(1)];  
  
    % Correct polynomial using Kalman filter  
    updatedCurveParams = correct(filter.curveFilter, ...  
        polynomial(1:2));  
    updatedDriftParams = correct(filter.driftFilter, ...  
        polynomial(3));  
  
    % Update the polynomial  
    polynomial = [updatedCurveParams,updatedDriftParams];  
    tracker.filteredDrift = [tracker.filteredDrift;polynomial(3)];  
    tracker.filteredCurveSmoothness = [tracker.filteredCurveSmoothness;  
        polynomial(1)];  
    varargout{1} = polynomial;  
    varargout{3} = tracker;  
end  
% Y-coordinate estimation  
yVal = polyval(polynomial,xVal);
```

```
% Z-coordinate estimation
zVal = (-modelParams(1)*xVal - ...
        modelParams(2)*yVal - modelParams(4))/modelParams(3);

% Final Curb
curb = [xVal' yVal' zVal'];
varargout{2} = curb;
end
```

## References

- [1] Zhang, Yihuan, Jun Wang, Xiaonian Wang, and John M. Dolan. "Road-Segmentation-Based Curb Detection Method for Self-Driving via a 3D-LiDAR Sensor." *IEEE Transactions on Intelligent Transportation Systems* 19, no. 12 (December 2018): 3981–91. <https://doi.org/10.1109/TITS.2018.2789462>.
- [2] Wang, Guojun, Jian Wu, Rui He, and Bin Tian. "Speed and Accuracy Tradeoff for LiDAR Data Based Road Boundary Detection." *IEEE/CAA Journal of Automatica Sinica* 8, no. 6 (June 2021): 1210–20. <https://doi.org/10.1109/JAS.2020.1003414>.
- [3] Hu, Jiuxiang, Anshuman Razdan, John C. Femiani, Ming Cui, and Peter Wonka. "Road Network Extraction and Intersection Detection From Aerial Images by Tracking Road Footprints." *IEEE Transactions on Geoscience and Remote Sensing* 45, no. 12 (December 2007): 4144–57. <https://doi.org/10.1109/TGRS.2007.906107>.

## Code Generation for Lidar Object Detection Using SqueezeSegV2 Network

This example shows how to generate CUDA® MEX code for a lidar object detection network. In the example, you first segment the point cloud with a pretrained network, then cluster the points and fit 3-D bounding boxes to each cluster. Finally, you generate MEX code for the network.

The lidar object detection network in this example is a SqueezeSegV2 [1 on page 1-0 ] network pretrained on the PandaSet data set, which contains 8240 unorganized lidar point cloud scans of various city scenes captured using a Pandar64 sensor. The network can segment 12 different classes and fit bounding boxes to objects in the car class.

### Third-Party Prerequisites

#### Required

- CUDA enabled NVIDIA® GPU and compatible driver

#### Optional

For non-MEX builds such as static libraries, dynamic libraries, or executables, this example has the following additional requirements.

- NVIDIA toolkit
- NVIDIA cuDNN library
- Environment variables for the compilers and libraries. For more information, see “Third-Party Hardware” (GPU Coder) and “Setting Up the Prerequisite Products” (GPU Coder).

### Verify GPU Environment

To verify if the compilers and libraries for running this example are set up correctly, use the `coder.checkGpuInstall` (GPU Coder) function.

```
envCfg = coder.gpuEnvConfig("host");
envCfg.DeepLibTarget = "cudnn";
envCfg.DeepCodegen = 1;
envCfg.Quiet = 1;
coder.checkGpuInstall(envCfg);
```

### Load SqueezeSegV2 Network and Entry-Point Function

Use the `getSqueezeSegV2PandasentNet` function, attached to this example as a supporting file, to load the pretrained SqueezeSegV2 network. For more information on how to train this network, see “Lidar Point Cloud Semantic Segmentation Using SqueezeSegV2 Deep Learning Network” on page 1-173.

```
net = getSqueezeSegV2PandasentNet;
```

The pretrained network is a DAG network. To display an interactive visualization of the network architecture, use the `analyzeNetwork` (Deep Learning Toolbox) function.

The `segmentClusterDetect` entry-point function takes in the organized point cloud matrix as an input and passes it to a trained network to segment, cluster and detect the bounding boxes. The `segmentClusterDetect` function loads the network object into a persistent variable and reuses the persistent object for subsequent prediction calls.

```

type('segmentClusterDetect.m');

function [op,bboxes] = segmentClusterDetect(I)
% Entry point function to segment, cluster and fit 3-D boxes.
% Copyright 2021 The MathWorks, Inc.

%#codegen

persistent net;

if isempty(net)
    net = coder.loadDeepLearningNetwork('trainedSqueezeSegV2PandasetNet.mat');
end

% Pass input.
predictedResult = predict(net,I);
[~,op] = max(predictedResult,[],3);

% Get the indices of points for the required class.
carIdx = (op == 7);

% Select the points of required class and cluster them based on distance.
ptCldMod = select(pointCloud(I(:,:,1:3)),carIdx);
[labels,numClusters] = pcsegdist(ptCldMod,0.5);

% Select each cluster and fit a cuboid to each cluster.
bboxes = zeros(0,9);
for num = 1:numClusters
    labelIdx = (labels == num);

    % Ignore cluster that has points less than 150 points.
    if sum(labelIdx,'all') < 150
        continue;
    end

    pcSeg = select(ptCldMod,labelIdx);
    mdl = pcfiteuboid(pcSeg);
    bboxes = [bboxes;mdl.Parameters];
end

end
end

```

### Execute Entry-Point Function

Read the point cloud and convert it to organized format using `pcorganize` function. For more details on unorganized to organized point cloud conversion, see the “Unorganized to Organized Conversion of Point Clouds Using Spherical Projection” on page 1-265 example.

```

ptCloudIn = pcread("pandasetDrivingData.pcd");

vbeamAngles = [15.0000  11.0000  8.0000  5.0000  3.0000  2.0000  1.8333  1.6667  :
                0.5000  0.3333  0.1667  0  -0.1667  -0.3333  -0.5000  -0.6667  -
                -1.8333  -2.0000  -2.1667  -2.3333  -2.5000  -2.6667  -2.8333  -3.0000  -
                -4.1667  -4.3333  -4.5000  -4.6667  -4.8333  -5.0000  -5.1667  -5.3333  -
                -9.0000  -10.0000  -11.0000  -12.0000  -13.0000  -14.0000  -19.0000  -25.0000];

hResolution = 1856;
params = lidarParameters(vbeamAngles,hResolution);
ptCloudOrg = pcorganize(ptCloudIn,params);

```

Convert the organized point cloud to a 5-channel input image using the `helperPointCloudToImage` function, attached to the example as a supporting file.

```
I = helperPointCloudToImage(ptCloudOrg);
```

Use the `segmentClusterDetect` entry-point function to get the predicted bounding boxes for cars and the segmentation labels.

```
[op,bboxes] = segmentClusterDetect(I);
```

Get the location and color map of the output.

```
cmap = helperLidarColorMap;  
colormap = cmap(op,:);  
loc = reshape(I(:,:,1:3),[],3);
```

Display the point cloud with segmentation output and bounding boxes.

```
figure  
ax = pcshow(loc,colormap);  
showShape("cuboid",bboxes,Parent=ax,Opacity=0.1,...  
         Color="green",LineWidth=0.5);  
zoom(ax,2);
```

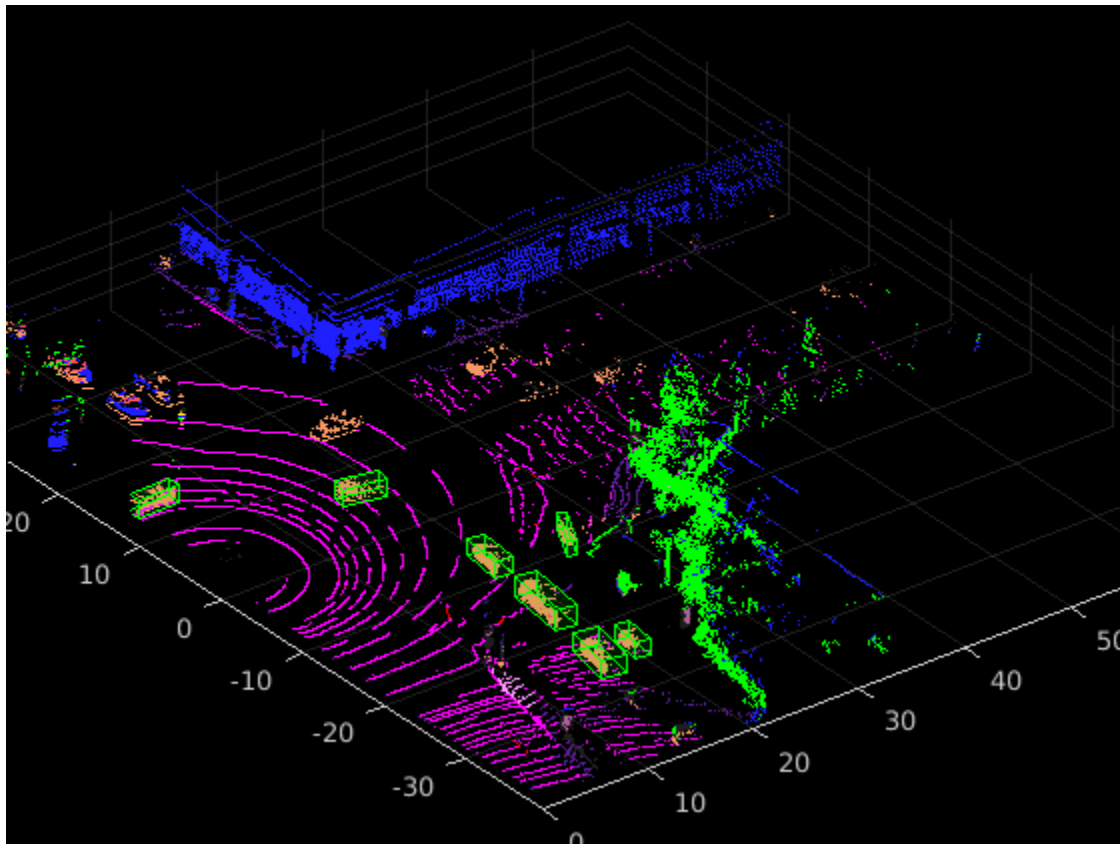

### Generate CUDA MEX Code

To generate CUDA® code for the `segmentClusterDetect` entry-point function, create a GPU code configuration object for a MEX target and set the target language to C++. Use the

`coder.DeepLearningConfig` (GPU Coder) function to create a CuDNN deep learning configuration object and assign it to the `DeepLearningConfig` property of the GPU code configuration object.

```
cfg = coder.gpuConfig('mex');
cfg.TargetLang = 'C++';
cfg.DeepLearningConfig = coder.DeepLearningConfig(TargetLibrary='cudnn');

args = {coder.typeof(I,[64 1856 5],[0 0 0])};

codegen -config cfg segmentClusterDetect -args args -report
```

Code generation successful: [View report](#)

To generate CUDA® code for the TensorRT target, create and use a TensorRT deep learning configuration object instead of the CuDNN configuration object.

### Run Generated MEX Code

Call the generated CUDA MEX code on the 5-channel image `I`, created from `ptCloudIn`.

```
[op,bboxes] = segmentClusterDetect_mex(I);
```

Get the color map of the output.

```
colormap = cmap(op,:);
```

Display the output.

```
figure
ax1 = pcshow(loc,colormap);
showShape("cuboid",bboxes,Parent=ax1,Opacity=0.1,...
         Color="green",LineWidth=0.5);
zoom(ax1,2);
```

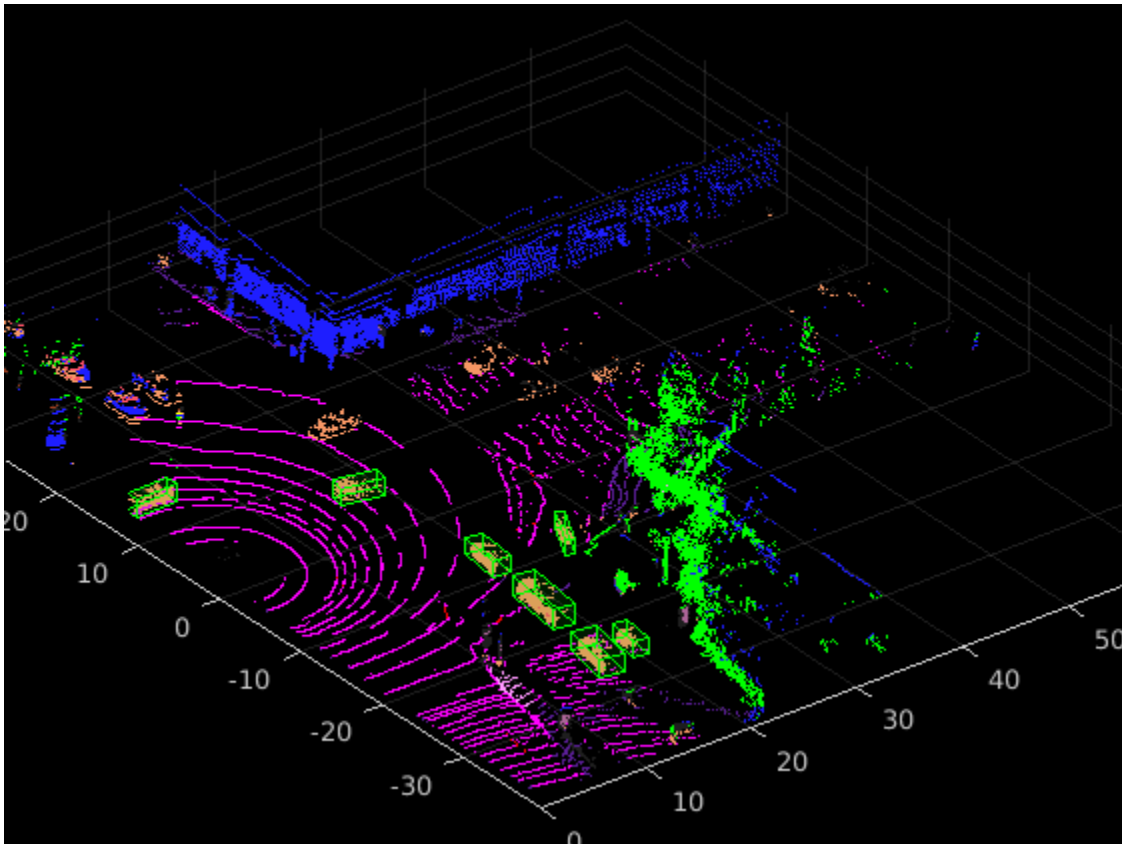

## Supporting Functions

### Define Lidar Color Map

The `helperLidarColorMap` function defines the colormap used by the lidar dataset.

```
function cmap = helperLidarColorMap
% Lidar color map for the pandaset classes

cmap = [[30 30 30];      % UnClassified
        [0 255 0];      % Vegetation
        [255 150 255];  % Ground
        [255 0 255];    % Road
        [255 0 0];      % Road Markings
        [90 30 150];    % Side Walk
        [245 150 100];  % Car
        [250 80 100];   % Truck
        [150 60 30];    % Other Vehicle
        [255 255 0];    % Pedestrian
        [0 200 255];    % Road Barriers
        [170 100 150];  % Signs
        [30 30 255]];   % Building

cmap = cmap./255;

end
```



## References

- [1] Wu, Bichen, Xuanyu Zhou, Sicheng Zhao, Xiangyu Yue, and Kurt Keutzer. "SqueezeSegV2: Improved Model Structure and Unsupervised Domain Adaptation for Road-Object Segmentation from a LiDAR Point Cloud." In *2019 International Conference on Robotics and Automation (ICRA)*, 4376-82. Montreal, QC, Canada: IEEE, 2019. <https://doi.org/10.1109/ICRA.2019.8793495>.
- [2] PandaSet is provided by Hesai and Scale under the CC-BY-4.0 license.

## Lidar Object Detection Using Complex-YOLO v4 Network

This example shows how to train a Complex-YOLO v4 network to perform object detection on point clouds.

The Complex-YOLO [1 on page 1-0 ] approach is effective for lidar object detection as it directly operates on bird's-eye-view RGB maps that are transformed from the point clouds. In this example, using the Complex-YOLO approach, you train a YOLO v4 [2 on page 1-0 ] network to predict both 2-D box positions and orientation in the bird's-eye-view frame. You then project the 2-D positions along with the orientation predictions back onto the point cloud to generate 3-D bounding boxes around the object of interest.

### Download Lidar Data Set

This example uses a subset of the PandaSet data set [3 on page 1-0 ] that contains 2560 preprocessed organized point clouds. Each point cloud covers 360 degrees of view and is specified as a 64-by-1856 matrix. The point clouds are stored in PCD format and their corresponding ground truth data is stored in the `PandaSetLidarGroundTruth.mat` file. The file contains 3-D bounding box information for three classes, which are car, truck, and pedestrian. The size of the data set is 5.2 GB.

Download the PandaSet data set from the given URL using the `helperDownloadPandasetData` helper function, defined at the end of this example.

```
outputFolder = fullfile(tempdir, 'Pandaset');

lidarURL = ['https://ssd.mathworks.com/supportfiles/lidar/data/' ...
           'Pandaset_LidarData.tar.gz'];

helperDownloadPandasetData(outputFolder, lidarURL);
```

Depending on your internet connection, the download process can take some time. The code suspends MATLAB® execution until the download process is complete. Alternatively, you can download the data set to your local disk using your web browser and extract the file. If you do so, change the `outputFolder` variable in the code to the location of the downloaded file. The download file contains `Lidar`, `Cuboids`, and `semanticLabels` folders, which contain the point clouds, cuboid label information, and semantic label information respectively.

### Download Pretrained Model

This example implements two variants of the complex YOLO v4 object detectors:

- `complex-yolov4-pandaset` — Standard complex YOLO v4 network trained on bird's-eye-view generated from point clouds of the PandaSet data set
- `tiny-complex-yolov4-pandaset` — Lightweight complex YOLO v4 network trained on bird's-eye-view images generated from point clouds of the PandaSet data set

The pretrained networks are trained on three object categories: car, truck and pedestrian.

```
modelName = 'tiny-complex-yolov4-pandaset';
mdl = downloadPretrainedComplexYOLOv4(modelName);
net = mdl.net;
```

### Load Data

Create a file datastore to load the PCD files from the specified path using the `pcread` function.

```
path = fullfile(outputFolder, 'Lidar');
lidarData = fileDatastore(path, 'ReadFcn', @(x) pcread(x));
```

Load the 3-D bounding box labels of the car, truck, and pedestrian objects.

```
gtPath = fullfile(outputFolder, 'Cuboids', 'PandaSetLidarGroundTruth.mat');
data = load(gtPath, 'lidarGtLabels');
Labels = timetable2table(data.lidarGtLabels);
boxLabels = Labels(:,2:end);
```

Display the full-view point cloud.

```
figure
ptCld = read(lidarData);
ax = pcshow(ptCld.Location);
set(ax, 'XLim', [-50 50], 'YLim', [-40 40]);
zoom(ax, 2.5);
axis off;
```

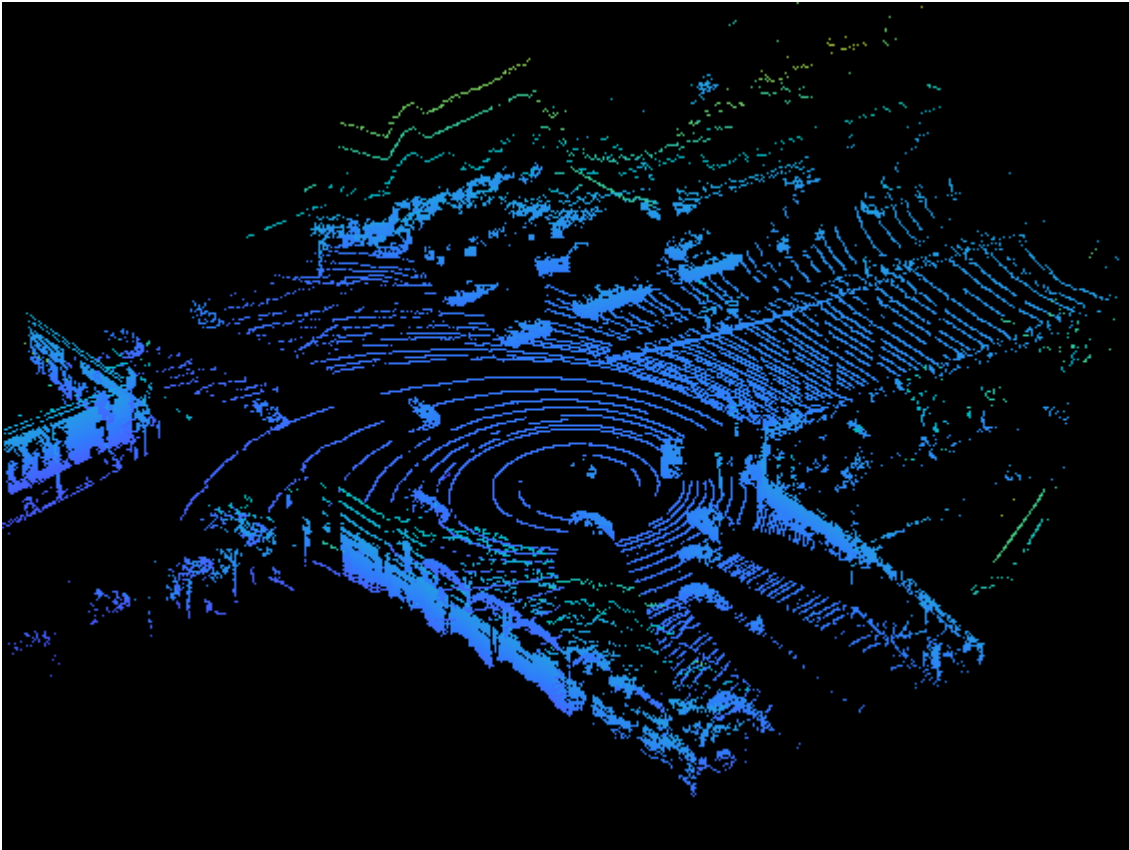

### Create Bird's-eye-view Image from Point Cloud Data

The PandaSet data consists of full-view point clouds. For this example, crop the full-view point clouds and convert them to a bird's-eye-view images using the standard parameters. These parameters determine the size of the input passed to the network. Selecting a smaller range of point clouds along the x-, y-, and z-axes helps you detect objects that are closer to the origin.

```
xMin = -25.0;
xMax = 25.0;
```

```
yMin = 0.0;  
yMax = 50.0;  
zMin = -7.0;  
zMax = 15.0;
```

Define the dimensions for the bird's-eye-view image.

```
bevHeight = 608;  
bevWidth = 608;
```

Find the grid resolution.

```
gridW = (yMax - yMin)/bevWidth;  
gridH = (xMax - xMin)/bevHeight;
```

Define the grid parameters.

```
gridParams = {{xMin,xMax,yMin,yMax,zMin,zMax},{bevWidth,bevHeight},{gridW,gridH}};
```

Convert the training data to bird's-eye-view images by using the `transformPCtoBEV` helper function, attached to this example as a supporting file. You can set `writeFiles` to `false` if your training data is already present in the `outputFolder`.

```
writeFiles = true;  
if writeFiles  
    transformPCtoBEV(lidarData,boxLabels,gridParams,outputFolder);  
end
```

### **Create Datastore Objects for Training**

Create a datastore for loading the bird's-eye-view images.

```
dataPath = fullfile(outputFolder,'BEVImages');  
imds = imageDatastore(dataPath);
```

Create a datastore for loading the ground truth boxes.

```
labelPath = fullfile(outputFolder,'Cuboids','BEVGroundTruthLabels.mat');  
load(labelPath,'processedLabels');  
blDs = boxLabelDatastore(processedLabels);
```

Remove the data that has no labels from the training data.

```
[imds,blDs] = removeEmptyData(imds,blDs);
```

Split the data set into a training set for training the network and a test set for evaluating the network. Use 60% of the data for training set and the rest for testing..

```
rng(0);  
shuffledIndices = randperm(size(imds.Files,1));  
idx = floor(0.6 * length(shuffledIndices));
```

Split the image datastore into training and test sets.

```
imdsTrain = subset(imds,shuffledIndices(1:idx));  
imdsTest = subset(imds,shuffledIndices(idx+1:end));
```

Split the box label datastore into training and test sets.

```
bldsTrain = subset(blds,shuffledIndices(1:idx));
bldsTest = subset(blds,shuffledIndices(idx+1:end));
```

Combine the image and box label datastores.

```
trainData = combine(imdsTrain,bldsTrain);
testData = combine(imdsTest,bldsTest);
```

Use the `validateInputDataComplexYOLOv4` helper function, attached to this example as a supporting file, to detect:

- Samples with an invalid image format or that contain NaNs
- Bounding boxes containing zeros, NaNs, Infs, or are empty
- Missing or noncategorical labels.

The values of the bounding boxes must be finite and positive and cannot be NaNs. They must also be within the image boundary with a positive height and width.

```
validateInputDataComplexYOLOv4(trainData);
validateInputDataComplexYOLOv4(testData);
```

### Preprocess Training Data

Preprocess the training data to prepare for training. The `preprocessData` helper function, listed at the end of the example, applies the following operations to the input data.

- Resize the images to the network input size.
- Scale the image pixels in the range [0 1].
- Set `isRotRect` to `true` to return the rotated rectangles.

```
networkInputSize = [608 608 3];
isRotRect = true;
preprocessedTrainingData = transform(trainData,@(data)preprocessData(data,networkInputSize,isRotRect));
```

Read the preprocessed training data.

```
data = read(preprocessedTrainingData);
```

Display an image with the bounding boxes.

```
I = data{1,1};
bbox = data{1,2};
labels = data{1,3};
helperDisplayBoxes(I,bbox,labels);
```



Reset the datastore.

```
reset(preprocessedTrainingData);
```

### **Modify Pretrained Complex-YOLO V4 Network**

The Complex-YOLO V4 network uses anchor boxes estimated from the training data to have better initial estimate corresponding to the type of data set and to help the network learn to predict the boxes accurately.

First, because the training images vary in size, use the `transform` function to preprocess the training data and resize all the images to the same size.

Specify the number of anchors:

- `complex-yolov4-pandaset model` — Specify 9 anchors
- `tiny-complex-yolov4-pandaset model` — Specify 6 anchors

Use the `estimateAnchorBoxes` function to estimate the anchor boxes. For reproducibility, set the random seed. Then pass the estimated anchor boxes to the `configureComplexYOLOV4` function to arrange them in the correct order for the training. Set `isRotRect` to false because the rotation angle is not necessary for the bounding boxes to estimate the anchors.

```
rng(0)
isRotRect = false;
trainingDataForEstimation = transform(trainData,@(data)preprocessData(data,networkInputSize,isRotRect));
numAnchors = 6;
[anchorBoxes,meanIoU] = estimateAnchorBoxes(trainingDataForEstimation,numAnchors)
```

```
anchorBoxes = 6x2
```

```
    23    52
    11    13
    12    17
    19     8
    25    60
    10    10
```

```
meanIoU = 0.7925
```

Specify the class names to use for training.

```
classNames = {'Car'
              'Truck'
              'Pedestrian'};
```

Configure the pretrained model for training using the `configureComplexYOLOV4` function. This function returns a the modified layer graph, network output names, reordered anchor boxes, and anchor box masks to select anchor boxes to use in the detected heads. Configure the detection head of the YOLO v4 model to predict the angle regression along with bounding boxes, the objectness score, and classification scores.

```
[net,networkOutputs,anchorBoxes] = configureComplexYOLOv4(net,classNames,anchorBoxes,modelName);
```

### Specify Training Options

Specify these training options.

- Set the number of epochs to 90.
- Set the mini batch size to 8. Stable training is possible with higher learning rates when higher mini batch size is used. Set this value depending on the memory available.
- Set the learning rate to 0.001.
- Set the warmup period to 1000 iterations. It helps in stabilizing the gradients at higher learning rates.
- Set the L2 regularization factor to 0.001.
- Specify the penalty threshold as 0.5. Detections that overlap less than 0.5 with the ground truth are penalized.
- Initialize the velocity of the gradient as `[ ]`, which is used by SGDM to store the velocity of the gradients.

```
maxEpochs = 90;
miniBatchSize = 8;
learningRate = 0.001;
warmupPeriod = 1000;
l2Regularization = 0.001;
penaltyThreshold = 0.5;
velocity = [];
```

### Train Model

Train on a GPU, if one is available. Using a GPU requires Parallel Computing Toolbox™ and a CUDA® enabled NVIDIA® GPU. For information on supported devices, see “GPU Support by Release” (Parallel Computing Toolbox).

Use the `minibatchqueue` function to split the preprocessed training data into batches with the supporting function `createBatchData`, defined at the end of the example, which returns the batched images and bounding boxes combined with the respective class IDs. For faster extraction of the batch data for training, set the `dispatchInBackground` to `true` to use a parallel pool.

`minibatchqueue` automatically detects whether a GPU is available. If you do not have a GPU or do not want to use one for training, set the `OutputEnvironment` parameter to `cpu`.

```
if canUseParallelPool
    dispatchInBackground = true;
else
    dispatchInBackground = false;
end

mbqTrain = minibatchqueue(preprocessedTrainingData,2, ...
    "MiniBatchSize",miniBatchSize,...
    "MiniBatchFcn",@(images,boxes,labels) createBatchData(images,boxes,labels,classNames), .
    "MiniBatchFormat",["SSCB",""],...
    "DispatchInBackground",dispatchInBackground,...
    "OutputCast",["","double"]);
```

Create the training progress plot using the supporting function `configureTrainingProgressPlotter`.

Finally, specify the custom training loop. For each iteration:

- Read data from the `minibatchqueue`. If it has no more data, reset the `minibatchqueue` and shuffle.
- Evaluate the model gradients using the `dlfeval` and the `modelGradients` supporting function, listed at the end of this example.
- Apply a weight decay factor to the gradients to regularization for more robust training.
- Determine the learning rate based on the iterations using the `piecewiseLearningRateWithWarmup` supporting function.
- Update the net parameters using the `sgdupdate` function.
- Update the state parameters of net with the moving average.
- Display the learning rate, total loss, and the individual losses (box loss, object loss, and class loss) for every iteration. Use these values to interpret how the respective losses change in each iteration. For example, a sudden spike in the box loss after a few iterations implies that the predictions contain Inf values or NaNs.



- Update the training progress plot.

You can terminate the training if the loss saturates for a few epochs.

```
doTraining = false;
```

```
if doTraining
    iteration = 0;

    % Create subplots for the learning rate and mini-batch loss.
    fig = figure;
    [lossPlotter, learningRatePlotter] = configureTrainingProgressPlotter(fig);

    % Custom training loop.
    for epoch = 1:maxEpochs

        reset(mbqTrain);
        shuffle(mbqTrain);

        while(hasdata(mbqTrain))
            iteration = iteration + 1;

            [XTrain,YTrain] = next(mbqTrain);

            % Evaluate the model gradients and loss using dlfeval and the
            % modelGradients function.
            [gradients,state,lossInfo] = dlfeval(@modelGradients,net,XTrain,YTrain,anchorBoxes,p

            % Apply L2 regularization.
            gradients = dlupdate(@(g,w) g + l2Regularization*w, gradients, net.Learnables);

            % Determine the current learning rate value.
            currentLR = piecewiseLearningRateWithWarmup(iteration,epoch,learningRate,warmupPeriod

            % Update the network learnable parameters using the SGDM optimizer.
            [net,velocity] = sgdmupdate(net,gradients,velocity,currentLR);

            % Update the state parameters of dlnetwork.
            net.State = state;

            % Display progress.
            if mod(iteration,10)==1
                displayLossInfo(epoch,iteration,currentLR,lossInfo);
            end

            % Update training plot with new points.
            updatePlots(lossPlotter,learningRatePlotter,iteration,currentLR,lossInfo.totalLoss);
        end
    end
else
    net = mdl.net;
    anchorBoxes = mdl.anchorBoxes;
end
```

To find optimal training options by sweeping through ranges of hyperparameter values, use the Deep Network Designer (Deep Learning Toolbox) app.

## Evaluate Model

Computer Vision Toolbox™ provides object detector evaluation functions to measure common metrics such as average precision (`evaluateDetectionAOS`) for rotated rectangles. This example uses the average orientation similarity (AOS) metric. AOS is a metric for measuring detector performance on rotated rectangle detections. This metric provides a single number that incorporates the ability of the detector to make correct classifications (precision) and the ability of the detector to find all relevant objects (recall).

```
% Create a table to hold the bounding boxes, scores, and labels returned by
% the detector.
results = table('Size',[0 3], ...
    'VariableTypes',{'cell','cell','cell'}, ...
    'VariableNames',{'Boxes','Scores','Labels'});

% Run the detector on images in the test set and collect the results.
reset(testData)
while hasdata(testData)
    % Read the datastore and get the image.
    data = read(testData);
    image = data{1,1};

    % Run the detector.
    executionEnvironment = 'auto';
    [bboxes,scores,labels] = detectComplexYOLOv4(net,image,anchorBoxes,classNames,executionEnvironment);

    % Collect the results.
    tbl = table({bboxes},{scores},{labels},'VariableNames',{'Boxes','Scores','Labels'});
    results = [results; tbl];
end

% Evaluate the object detector using the average precision metric.
metrics = evaluateDetectionAOS(results, testData)
```

```
metrics=3x5 table
```

	AOS	AP	OrientationSimilarity	Precision	Recall
Car	0.83079	0.90904	{7339x1 double}	{7339x1 double}	{7339x1 double}
Truck	0.46622	0.48079	{1134x1 double}	{1134x1 double}	{1134x1 double}
Pedestrian	0.6626	0.72495	{3439x1 double}	{3439x1 double}	{3439x1 double}

## Detect Objects Using Trained Complex-YOLO V4

Use the network for object detection.

```
% Read the datastore.
reset(testData)
data = read(testData);

% Get the image.
I = data{1,1};

% Run the detector.
executionEnvironment = 'auto';
[bboxes,scores,labels] = detectComplexYOLOv4(net,I,anchorBoxes,classNames,executionEnvironment);
```

```
% Display the output.  
figure  
helperDisplayBoxes(I,bboxes,labels);
```

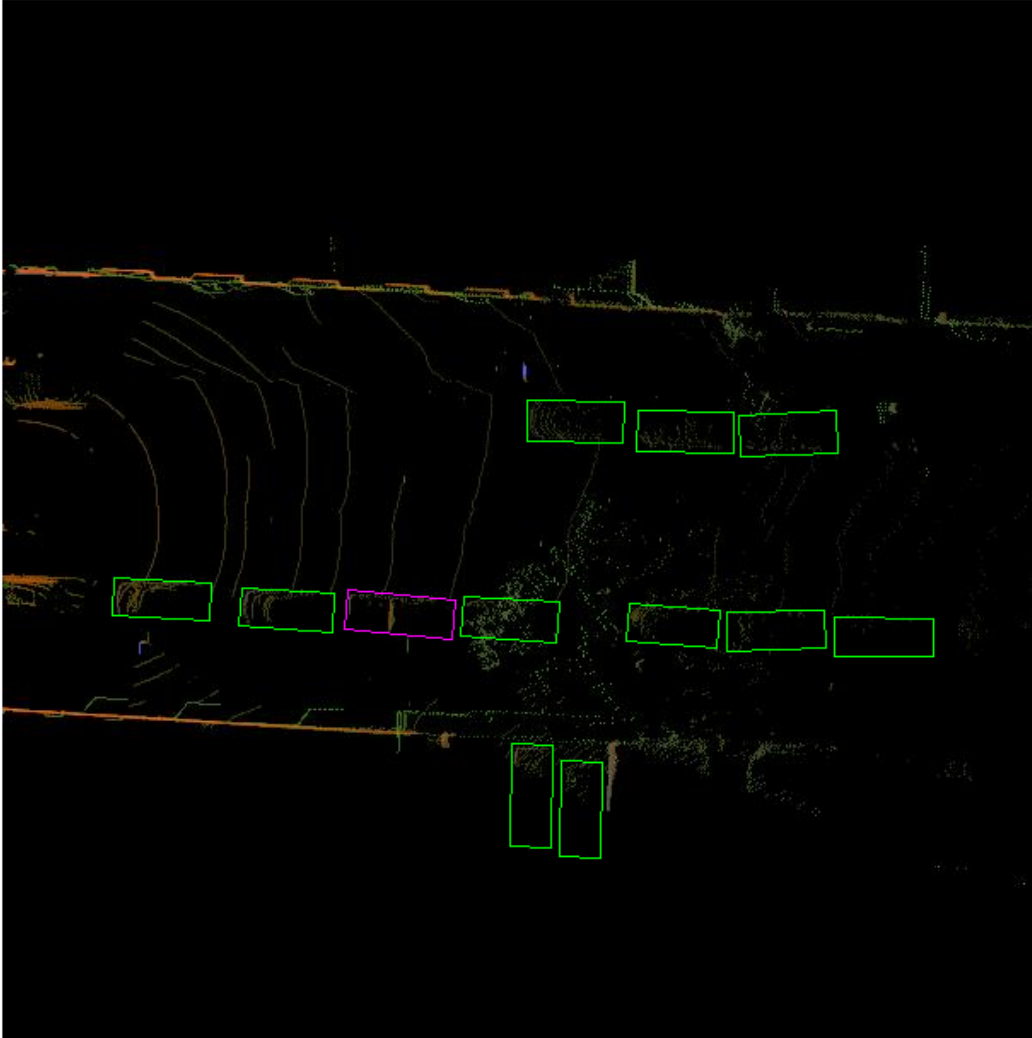

Transfer the detected boxes to a point cloud using the `transferbboxToPointCloud` helper function, attached to this example as a supporting file.

```
lidarTestData = subset(lidarData,shuffledIndices(idx+1:end));  
ptCld = read(lidarTestData);  
[ptCldOut,bboxCuboid] = transferbboxToPointCloud(bboxes,gridParams,ptCld);  
helperDisplayBoxes(ptCldOut,bboxCuboid,labels);
```

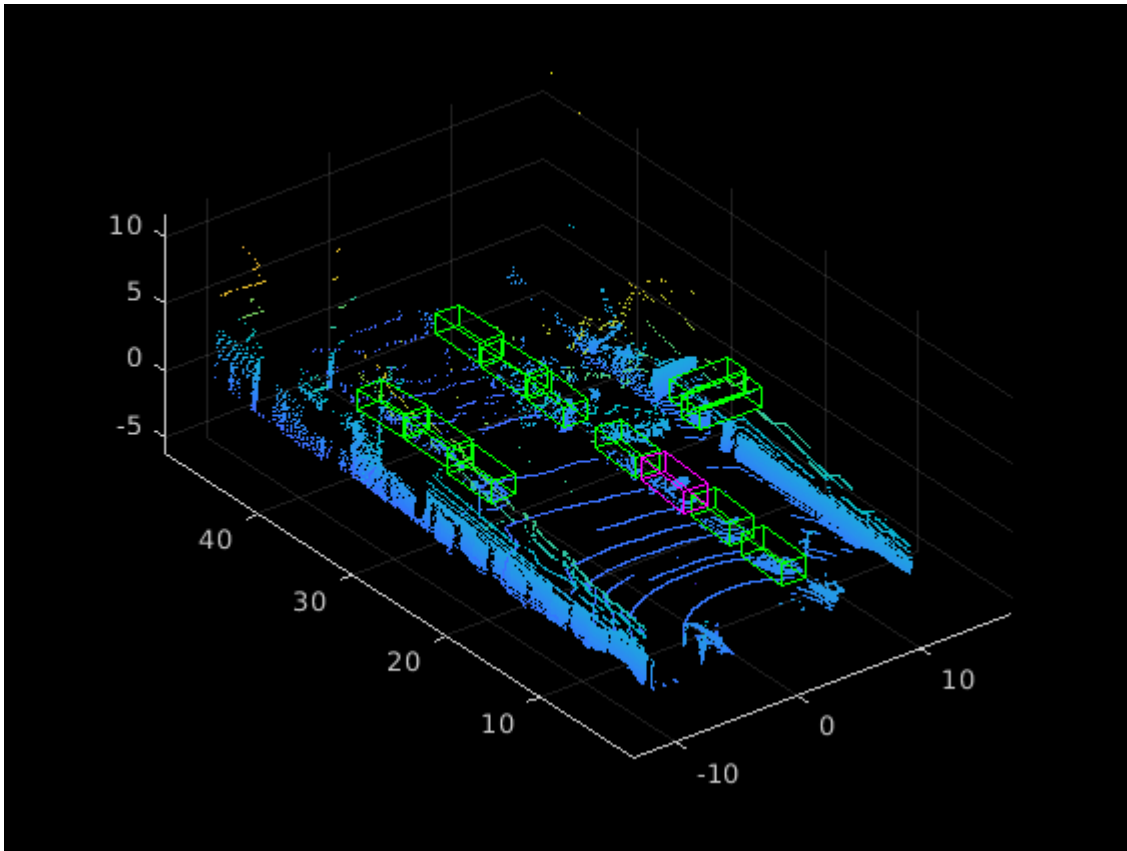

## Supporting Functions

### Model Gradients

The function `modelGradients` takes as input the Complex-YOLO v4 network, a mini-batch of input data `XTrain` with corresponding ground truth boxes `YTrain`, and the specified penalty threshold. It returns the gradients of the loss with respect to the learnable parameters in `net`, the corresponding mini-batch loss information, and the state of the current batch.

The `modelGradients` function computes the total loss and gradients by performing these operations.

- Generate predictions from the input batch of images using the `complexYOLOv4Forward` method.
- Collect predictions on the CPU for postprocessing.
- Convert the predictions from the Complex-YOLO v4 grid cell coordinates to bounding box coordinates to allow easy comparison with the ground truth data.
- Generate targets for loss computation by using the converted predictions and ground truth data. Generate the targets for bounding box positions (x, y, width, height, yaw), object confidence, and class probabilities. See the supporting function `generateComplexYOLOv4Targets`.
- Calculate the mean squared error of the predicted bounding box coordinates with target boxes using the supporting function `bboxOffsetLoss`, defined at the end of the example.
- Calculate the binary cross-entropy of the predicted object confidence score with a target object confidence score using the supporting function `objectnessLoss`, defined at the end of the example.

- Calculate the binary cross-entropy of the predicted class of object with the target using the supporting function `classConfidenceLoss`, defined at the end of the example.
- Compute the total loss as the sum of all losses.
- Compute the gradients of learnables with respect to the total loss.

```
function [gradients,state,info] = modelGradients(net,XTrain,YTrain,anchors,penaltyThreshold,netw

    inputImageSize = size(XTrain,1:2);

    % Gather the ground truths in the CPU for postprocessing.
    YTrain = gather(extractdata(YTrain));

    % Extract the predictions from the network.
    [YPredCell,state] = complexYOLOv4Forward(net,XTrain,networkOutputs,anchors);

    % Gather the activations in the CPU for postprocessing and extract darray data.
    gatheredPredictions = cellfun(@ gather,YPredCell(:,1:8),'UniformOutput',false);
    gatheredPredictions = cellfun(@ extractdata, gatheredPredictions,'UniformOutput', false);

    % Convert predictions from grid cell coordinates to box coordinates.
    tiledAnchors = generateTiledAnchorsComplexYolov4(gatheredPredictions(:,2:5),anchors);
    gatheredPredictions(:,2:5) = applyAnchorBoxOffsetsComplexYolov4(tiledAnchors,gatheredPredicti

    % Generate targets for predictions from the ground truth data.
    [boxTarget,objectnessTarget,classTarget,objectMaskTarget,boxErrorScale] = generateComplexYOL

    % Compute the loss.
    boxLoss = bboxOffsetLoss(YPredCell(:,[2 3 9 10 6 7]),boxTarget,objectMaskTarget,boxErrorScale
    objLoss = objectnessLoss(YPredCell(:,1),objectnessTarget,objectMaskTarget);
    clsLoss = classConfidenceLoss(YPredCell(:,8),classTarget,objectMaskTarget);
    totalLoss = boxLoss + objLoss + clsLoss;

    info.boxLoss = boxLoss;
    info.objLoss = objLoss;
    info.clsLoss = clsLoss;
    info.totalLoss = totalLoss;

    % Compute the gradients of learnables with regard to the loss.
    gradients = dlgradient(totalLoss,net.Learnables);
end
```

## Loss Functions

Compute the mean squared error for the bounding box position.

```
function boxLoss = bboxOffsetLoss(boxPredCell,boxDeltaTarget,boxMaskTarget,boxErrorScaleTarget)
    lossX = sum(cellfun(@(a,b,c,d) mse(a.*c.*d,b.*c.*d),boxPredCell(:,1),boxDeltaTarget(:,1),boxP
    lossY = sum(cellfun(@(a,b,c,d) mse(a.*c.*d,b.*c.*d),boxPredCell(:,2),boxDeltaTarget(:,2),boxP
    lossW = sum(cellfun(@(a,b,c,d) mse(a.*c.*d,b.*c.*d),boxPredCell(:,3),boxDeltaTarget(:,3),boxP
    lossH = sum(cellfun(@(a,b,c,d) mse(a.*c.*d,b.*c.*d),boxPredCell(:,4),boxDeltaTarget(:,4),boxP

    lossYaw1 = sum(cellfun(@(a,b,c,d) mse(a.*c.*d,b.*c.*d),boxPredCell(:,5),boxDeltaTarget(:,5),l
    lossYaw2 = sum(cellfun(@(a,b,c,d) mse(a.*c.*d,b.*c.*d),boxPredCell(:,6),boxDeltaTarget(:,6),l

    boxLoss = lossX+lossY+lossW+lossH+lossYaw1+lossYaw2;
end
```

Compute the binary cross-entropy loss for the class confidence score.

```
function clsLoss = classConfidenceLoss(classPredCell,classTarget,boxMaskTarget)
    clsLoss = sum(cellfun(@(a,b,c) crossentropy(a.*c,b.*c,'TargetCategories','independent'),classPredCell,classTarget,boxMaskTarget));
end
```

Compute the binary cross-entropy loss for the objectness score.

```
function objLoss = objectnessLoss(objectnessPredCell,objectnessDeltaTarget,boxMaskTarget)
    objLoss = sum(cellfun(@(a,b,c) crossentropy(a.*c,b.*c,'TargetCategories','independent'),objectnessPredCell,objectnessDeltaTarget,boxMaskTarget));
end
```

### Preprocess Data

```
function data = preprocessData(data,targetSize,isRotRect)
% Resize the images and scale the pixels to between 0 and 1. Also scale the
% corresponding bounding boxes.
for ii = 1:size(data,1)
    I = data{ii,1};
    imgSize = size(I);

    % Convert an input image with a single channel to three channels.
    if numel(imgSize) < 3
        I = repmat(I,1,1,3);
    end
    bboxes = data{ii,2};

    I = im2single(imresize(I,targetSize(1:2)));
    scale = targetSize(1:2)./imgSize(1:2);
    bboxes = bboxresize(bboxes,scale);

    if ~isRotRect
        bboxes = bboxes(:,1:4);
    end

    data(ii, 1:2) = {I,bboxes};
end
end
```

```
function [XTrain,YTrain] = createBatchData(data,groundTruthBoxes,groundTruthClasses,classNames)
% Return images combined along the batch dimension in XTrain and
% normalized bounding boxes concatenated with classIDs in YTrain.

% Concatenate images along the batch dimension.
XTrain = cat(4,data{:},1);

% Get class IDs from the class names.
classNames = repmat({categorical(classNames)}),size(groundTruthClasses);
[~,classIndices] = cellfun(@(a,b)ismember(a,b),groundTruthClasses,classNames,'UniformOutput',false);

% Append the label indexes and training image size to scaled bounding boxes
% and create a single cell array of responses.
combinedResponses = cellfun(@(bbox,classid)[bbox,classid],groundTruthBoxes,classIndices,'UniformOutput',false);
len = max(cellfun(@(x)size(x,1),combinedResponses));
paddedBBoxes = cellfun(@(v) padarray(v,[len-size(v,1),0],0,'post'),combinedResponses,'UniformOutput',false);
YTrain = cat(4,paddedBBoxes{:},1);
end
```

## Learning Rate Schedule Function

```
function currentLR = piecewiseLearningRateWithWarmup(iteration,epoch,learningRate,warmupPeriod,numEpochs)
% The piecewiseLearningRateWithWarmup function computes the current
% learning rate based on the iteration number.
    persistent warmUpEpoch;

    if iteration <= warmupPeriod
        % Increase the learning rate for the number of iterations in the warmup period.
        currentLR = learningRate*((iteration/warmupPeriod)^4);
        warmUpEpoch = epoch;
    elseif iteration >= warmupPeriod && epoch < warmUpEpoch+floor(0.6*(numEpochs-warmUpEpoch))
        % After the warmup period, keep the learning rate constant if the remaining number of epochs is
        % more than 60 percent but less than 90 percent, multiply the learning rate by 0.1.
        currentLR = learningRate;

    elseif epoch >= warmUpEpoch + floor(0.6*(numEpochs-warmUpEpoch)) && epoch < warmUpEpoch+floor(0.9*(numEpochs-warmUpEpoch))
        % If the remaining number of epochs is more than 60 percent but less
        % than 90 percent, multiply the learning rate by 0.1.
        currentLR = learningRate*0.1;

    else
        % If more than 90 percent of the epochs remain, multiply the learning
        % rate by 0.01.
        currentLR = learningRate*0.01;
    end
end
```

## Utility Functions

```
function [lossPlotter,learningRatePlotter] = configureTrainingProgressPlotter(f)
% Create the subplots to display the loss and learning rate.

    figure(f);
    clf
    subplot(2,1,1);
    ylabel('Learning Rate');
    xlabel('Iteration');
    learningRatePlotter = animatedline;
    subplot(2,1,2);
    ylabel('Total Loss');
    xlabel('Iteration');
    lossPlotter = animatedline;
end

function displayLossInfo(epoch,iteration,currentLR,lossInfo)
% Display loss information for each iteration.
    disp("Epoch : " + epoch + " | Iteration : " + iteration + " | Learning Rate : " + currentLR + " | Total Loss : " + double(gather(extractdata(lossInfo.totalLoss))) + ...
        " | Box Loss : " + double(gather(extractdata(lossInfo.boxLoss))) + ...
        " | Object Loss : " + double(gather(extractdata(lossInfo.objLoss))) + ...
        " | Class Loss : " + double(gather(extractdata(lossInfo.clsLoss))));
end

function updatePlots(lossPlotter,learningRatePlotter,iteration,currentLR,totalLoss)
% Update loss and learning rate plots.
    addpoints(lossPlotter,iteration,double(extractdata(gather(totalLoss))));
    addpoints(learningRatePlotter, iteration,currentLR);
    drawnow
```

```
end

function helperDisplayBoxes(obj,bboxes,labels)
% Display the boxes over the image and point cloud.
figure
if ~isa(obj,'pointCloud')
    imshow(obj)
    shape = 'rectangle';
else
    pcshow(obj.Location);
    shape = 'cuboid';
end
showShape(shape,bboxes(labels=='Car',:),...
           'Color','green','LineWidth',0.5);hold on;
showShape(shape,bboxes(labels=='Truck',:),...
           'Color','magenta','LineWidth',0.5);
showShape(shape,bboxes(labels=='Pedestrian',:),...
           'Color','yellow','LineWidth',0.5);
hold off;
end

function helperDownloadPandasetData(outputFolder,lidarURL)
% Download the data set from the given URL to the output folder.
lidarDataTarFile = fullfile(outputFolder,'Pandaset_LidarData.tar.gz');
if ~exist(lidarDataTarFile,'file')
    mkdir(outputFolder);
    disp('Downloading PandaSet Lidar driving data (5.2 GB)...');
    websave(lidarDataTarFile,lidarURL);
    untar(lidarDataTarFile,outputFolder);
end
% Extract the file.
if (~exist(fullfile(outputFolder,'Lidar'),'dir'))...
    &&(~exist(fullfile(outputFolder,'Cuboids'),'dir'))
    untar(lidarDataTarFile,outputFolder);
end
end
```

## References

- [1] Simon, Martin, Stefan Milz, Karl Amende, and Horst-Michael Gross. "Complex-YOLO: Real-Time 3D Object Detection on Point Clouds". *ArXiv:1803.06199 [Cs]*, 24 September 2018. <https://arxiv.org/abs/1803.06199>.
- [2] Bochkovski, Alexey, Chien-Yao Wang, and Hong-Yuan Mark Liao. "YOLOv4: Optimal Speed and Accuracy of Object Detection". *ArXiv:2004.10934 [Cs, Eess]*, 22 April 2020. <https://arxiv.org/abs/2004.10934>.
- [3] PandaSet is provided by Hesai and Scale under the CC-BY-4.0 license.



# Automate Ground Truth Labeling for Lidar Point Cloud Semantic Segmentation Using Lidar Labeler

This example shows how to automate semantic labeling in a point cloud using a pretrained semantic segmentation network in the Lidar Labeler app. In this example, you can use the `AutomationAlgorithm` class to automate labeling in the **Lidar Labeler** app.

## Lidar Labeler App

Good ground truth data is crucial for the development and performance evaluation of automated driving and flight algorithms. However, creating and maintaining a diverse, high-quality, and labeled data set requires significant effort. The **Lidar Labeler** app provides a framework to automate the labeling process using the `AutomationAlgorithm` class. You can create a custom algorithm and use it in the app to label your entire data set. You can also edit the results to account for challenging scenarios missed by the algorithm.

In this example, you:

- Use a pretrained SqueezeSegV2 semantic segmentation network to segment 3-D organized point cloud.
- Create an automation algorithm that you can use in the **Lidar Labeler** app to automatically segment vegetation, ground, road, road marking, sidewalk, car, truck, other vehicle, pedestrian, road barrier, sign, and building voxels in a point cloud using the SqueezeSegV2 network.

## Segment Point Cloud Using SqueezeSegV2 Network

Segment the point cloud using a pretrained SqueezeSegV2 network. For information on how to train a SqueezeSegV2 network yourself, see “Lidar Point Cloud Semantic Segmentation Using SqueezeSegV2 Deep Learning Network” on page 1-173. This pretrained network is for organized point clouds. For information on how to convert unorganized point clouds to organized point clouds, see “Unorganized to Organized Conversion of Point Clouds Using Spherical Projection” on page 1-265.

## Download Pretrained Network

Download the pretrained SqueezeSegV2 network, which has been trained on the PandaSet data set.

```
outputFolder = fullfile(tempdir,"Pandaset");
preTrainedMATFile = fullfile(outputFolder,"trainedSqueezeSegV2PandasetNet.mat");
preTrainedZipFile = fullfile(outputFolder,"trainedSqueezeSegV2PandasetNet.zip");

if ~exist(preTrainedMATFile,"file")
    if ~exist(preTrainedZipFile,"file")
        disp("Downloading pretrained model (5 MB)...");
        component = "lidar";
        filename = "data/trainedSqueezeSegV2PandasetNet.zip";
        preTrainedZipFile = matlab.internal.examples.downloadSupportFile(component,filename);
    end
    unzip(preTrainedZipFile,outputFolder);
end
```

## Download Lidar Data Set

Download the PandaSet data set from Hesai and Scale, and save the lidar data to a Pandaset folder in a temporary folder. Note that the data set is 5.2 GB in size, and the code suspends MATLAB®

execution until the download process is complete. To avoid suspending MATLAB execution during the download you can download the data set to your local disk, and then extract the file.

```
lidarDataTarFile = fullfile(outputFolder,"Pandaset_LidarData.tar.gz");
if ~exist(lidarDataTarFile,"file")
    disp("Downloading Pandaset Lidar driving data (5.2BG)...");
    component = "lidar";
    filename = "data/Pandaset_LidarData.tar.gz";
    lidarDataTarFile = matlab.internal.examples.downloadSupportFile(component,filename);
    untar(lidarDataTarFile,outputFolder);
end

% Check if tar.gz file is downloaded, but not uncompressed.
if ~exist(fullfile(outputFolder,"Lidar"),"file")
    untar(lidarDataTarFile,outputFolder);
end
```

### **Predict Segmentation Result on Point Cloud**

Use the trained network to predict results on a point cloud by following these steps:

- Load the pretrained SqueezeSegV2 network into the workspace.
- Read the point cloud.
- Convert the point cloud to five-channel image using the helperPointCloudToImage on page 1-0 function, defined in the Supporting Functions on page 1-0 section of this example.
- Use the semanticseg function to predict the semantic result on the five-channel input image.
- Display the segmentation result on the point cloud using the helperDisplayLabelOverlaidPointCloud on page 1-0 function, defined in the Supporting Functions on page 1-0 section of this example.

```
% Load the pretrained network.
outputFolder = fullfile(tempdir,"Pandaset");
load(fullfile(outputFolder,"trainedSqueezeSegV2PandasetNet.mat"),"net");

% Read the point cloud.
ptCloud = pcread(fullfile(outputFolder,"Lidar","0001.pcd"));

% Convert the point cloud to 5-channel image.
im = helperPointCloudToImage(ptCloud);

% Predict the segmentation result.
predictedResult = semanticseg(im,net);

% Display semantic segmentation result on point cloud.
helperDisplayLabelOverlaidPointCloud(im,predictedResult);
view([39.2 90.0 60])
title("Semantic Segmentation Result on Point Cloud")
```

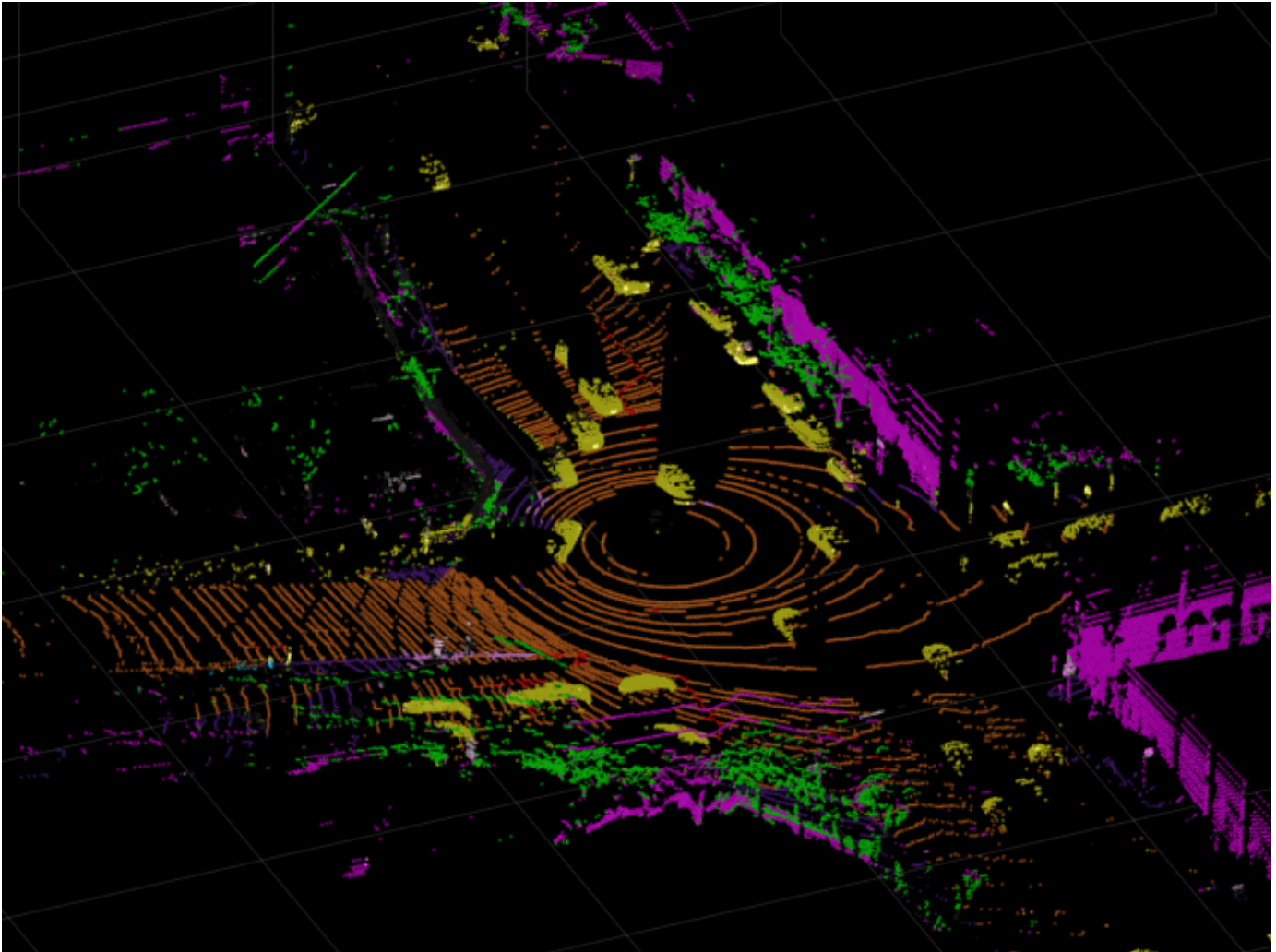

### Prepare Lidar Semantic Segmentation Automation Class

Construct an automation class for the lidar semantic segmentation algorithm. The class inherits from the `lidar.labeler.AutomationAlgorithm` abstract base class. The base class defines properties and signatures for methods that the app uses to configure and run the custom algorithm. The **Lidar Labeler** app provides an initial automation class template. For more information, see “Create Automation Algorithm for Labeling” on page 2-17. The `LidarSemanticSegmentation` class is based on this template, and provides you with a ready-to-use automation class for semantic segmentation in a point cloud. The comments of the class outline the basic steps required to implement each API call.

#### Algorithm Properties

First, define the properties that determine the name and description of the algorithm, as well as the directions for using the algorithm.

```
% -----
% Step 1: Define the required properties describing the algorithm. This
% includes Name, Description, and UserDirections.
properties(Constant)
```

```
% Name Algorithm Name
% Character vector specifying the name of the algorithm.
Name = 'Lidar Semantic Segmentation';

% Description Algorithm Description
% Character vector specifying the short description of the algorithm.
Description = 'Segment the point cloud using SqueezeSegV2 network';

% UserDirections Algorithm Usage Directions
% Cell array of character vectors specifying directions for
% algorithm users to follow to use the algorithm.
UserDirections = [{'ROI Label Definition: select one of ' ...
    'the ROI definitions to be labeled'], ...
    'Run: Press RUN to run the automation algorithm. ', ...
    ['Review and Modify: Review automated labels over the interval ', ...
    'using playback controls. Modify/delete/add ROIs that were not ' ...
    'satisfactorily automated at this stage. If the results are ' ...
    'satisfactory, click Accept to accept the automated labels.'], ...
    ['Accept/Cancel: If the results of automation are satisfactory, ' ...
    'click Accept to accept all automated labels and return to ' ...
    'manual labeling. If the results of automation are not ' ...
    'satisfactory, click Cancel to return to manual labeling ' ...
    'without saving the automated labels.'];
end
```

### Custom Properties

Next, define the custom properties required for the core algorithm.

```
% -----
% Step 2: Define properties you want to use during the algorithm
% execution.
properties
    % AllCategories
    % AllCategories holds the default 'unlabelled', 'Vegetation',
    % 'Ground', 'Road', 'RoadMarkings', 'SideWalk', 'Car', 'Truck',
    % 'OtherVehicle', 'Pedestrian', 'RoadBarriers', 'Signs',
    % 'Buildings' categorical types.
    AllCategories = {'unlabelled'};

    % PretrainedNetwork
    % PretrainedNetwork saves the pretrained SqueezeSegV2 network.
    PretrainedNetwork
end
```

### Function Definitions

For the third step, define the function used to check for valid data and label definitions.

The `checkSignalType` function checks if the signal data is supported for automation. The lidar semantic segmentation algorithm supports signals of type `PointCloud`.

```
function isValid = checkSignalType(signalType)
    % Only point cloud signal data is valid for the Lidar Vehicle
    % detector algorithm.
    isValid = (signalType == vision.labeler.loading.SignalType.PointCloud);
end
```

The `checkLabelDefinition` function checks if the label definition is the appropriate type for automation. The lidar semantic segmentation algorithm requires the `Voxel` label type.

```
function isValid = checkLabelDefinition(algObj, labelDef)
    % Only Voxel ROI label definitions are valid for the Lidar
    % semantic segmentation algorithm.
    isValid = labelDef.Type == lidarLabelType.Voxel;
    if isValid
        algObj.AllCategories{end+1} = labelDef.Name;
    end
end
```

The `checkSetup` function checks if an ROI label definition is selected for automation.

```
function isReady = checkSetup(algObj)
    % Is there one selected ROI Label definition to automate.
    isReady = ~isempty(algObj.SelectedLabelDefinitions);
end
```

### Execution Functions

Specify the execution functions. The `initialize` function populates the initial algorithm state based on the existing labels in the app. In this example, the `initialize` function loads the pretrained semantic segmentation network and saves it to the `PretrainedNetwork` property of the algorithm object.

```
function initialize(algObj,~)
    % Load the pretrained SqueezeSegV2 semantic segmentation network.
    outputFolder = fullfile(tempdir, 'Pandaset');
    pretrainedSqueezeSeg = load(fullfile(outputFolder, 'trainedSqueezeSegV2PandasetNet.mat'));
    % Store the network in the 'PretrainedNetwork' property of this object.
    algObj.PretrainedNetwork = pretrainedSqueezeSeg.net;
end
```

The `run` function defines the core lidar semantic segmentation algorithm of this automation class. The algorithm calls the `run` function for each frame of the point cloud sequence. The function expects the automation class to return a set of labels. You can extend the algorithm to any category the network is trained on. For the purposes of this example, restrict the network to segment voxels of the categories `vegetation`, `ground`, `road`, `road markings`, `sidewalk`, `cars`, `trucks`, `other vehicles`, `pedestrian`, `road barrier`, `signs`, and `buildings`.

```
function autoLabels = run(algObj, pointCloud)
    % Setup categorical matrix with categories including default
    % 'unlabelled', 'Vegetation', 'Ground', 'Road', 'RoadMarkings',
    % 'SideWalk', 'Car', 'Truck', 'OtherVehicle', 'Pedestrian',
    % 'RoadBarriers', and 'Signs'.
    autoLabels = categorical(zeros(size(pointCloud.Location,1),size(pointCloud.Location,2)), ...
        0:12,algObj.AllCategories);

    % Convert the input point cloud to five channel image.
    I = helperPointCloudToImage(pointCloud);

    % Predict the segmentation result.
    predictedResult = semanticseg(I,algObj.PretrainedNetwork);
    autoLabels(:) = predictedResult;
end
```

The `terminate` function handles any cleanup or tear-down required after the automation is done. This algorithm does not require any cleanup, so the function is empty.

### Use Lidar Semantic Segmentation Automation Class in App

To use the properties and methods implemented in the `LidarSemanticSegmentation` automation algorithm class file with **Lidar Labeler**, you must import the algorithm into the app.

First, create the folder structure `+lidar/+labeler` under the current folder, and copy the automation class into it.

```
mkdir('+lidar/+labeler');
copyfile(fullfile(matlabroot,'examples','lidar','main','LidarSemanticSegmentation.m'), ...
         '+lidar/+labeler');
```

Next, open the **Lidar Labeler** app and load the PandaSet point cloud sequence.

```
pointCloudDir = fullfile(outputFolder,'Lidar');
lidarLabeler(pointCloudDir);
```

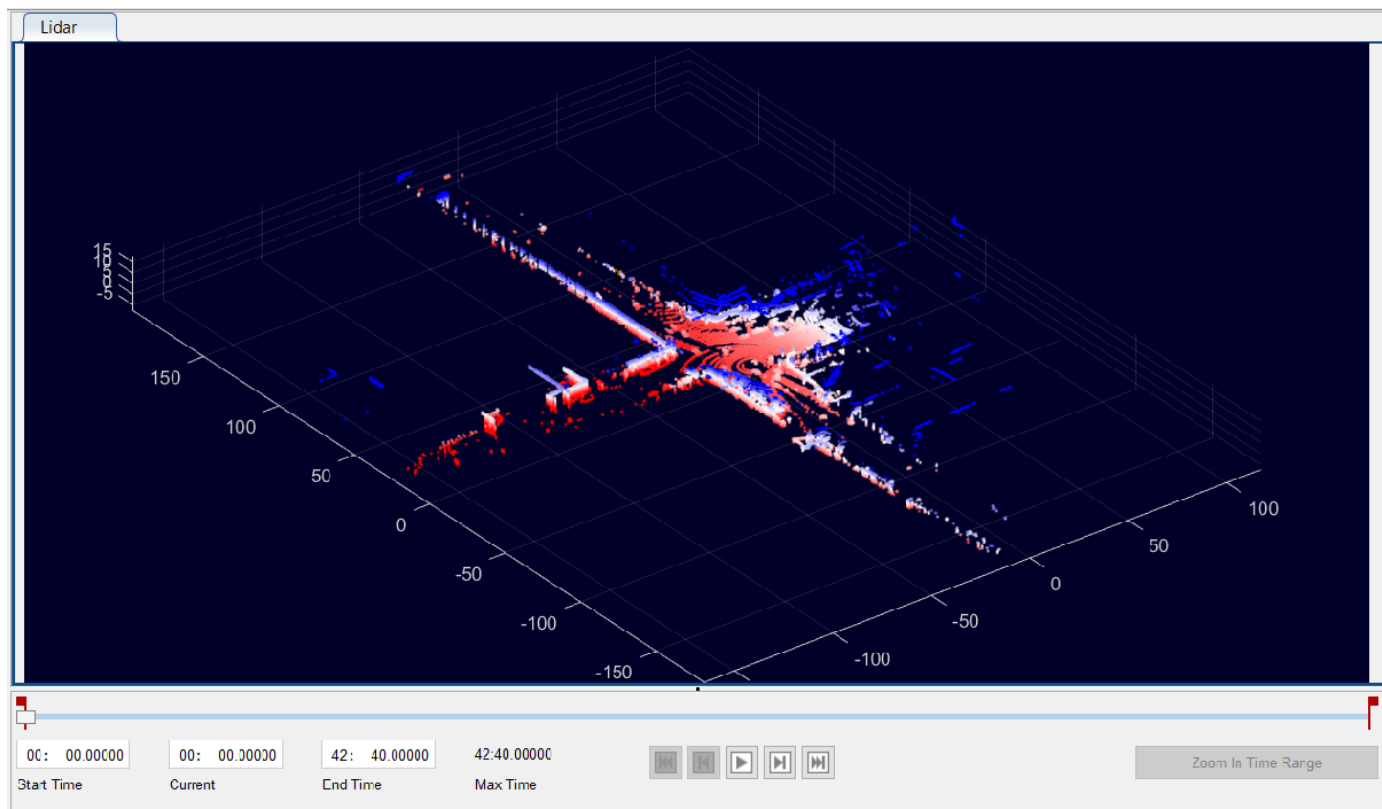

In the **ROI Labels** tab in the left pane, click **Label**. Define 12 ROI labels with the names `Vegetation`, `Ground`, `Road`, `RoadMarkings`, `SideWalk`, `Car`, `Truck`, `OtherVehicle`, `Pedestrian`, `RoadBarriers`, `Signs`, and `Buildings`, of label type `Voxel`. Optionally, you can select colors for the labels. Click **OK**.

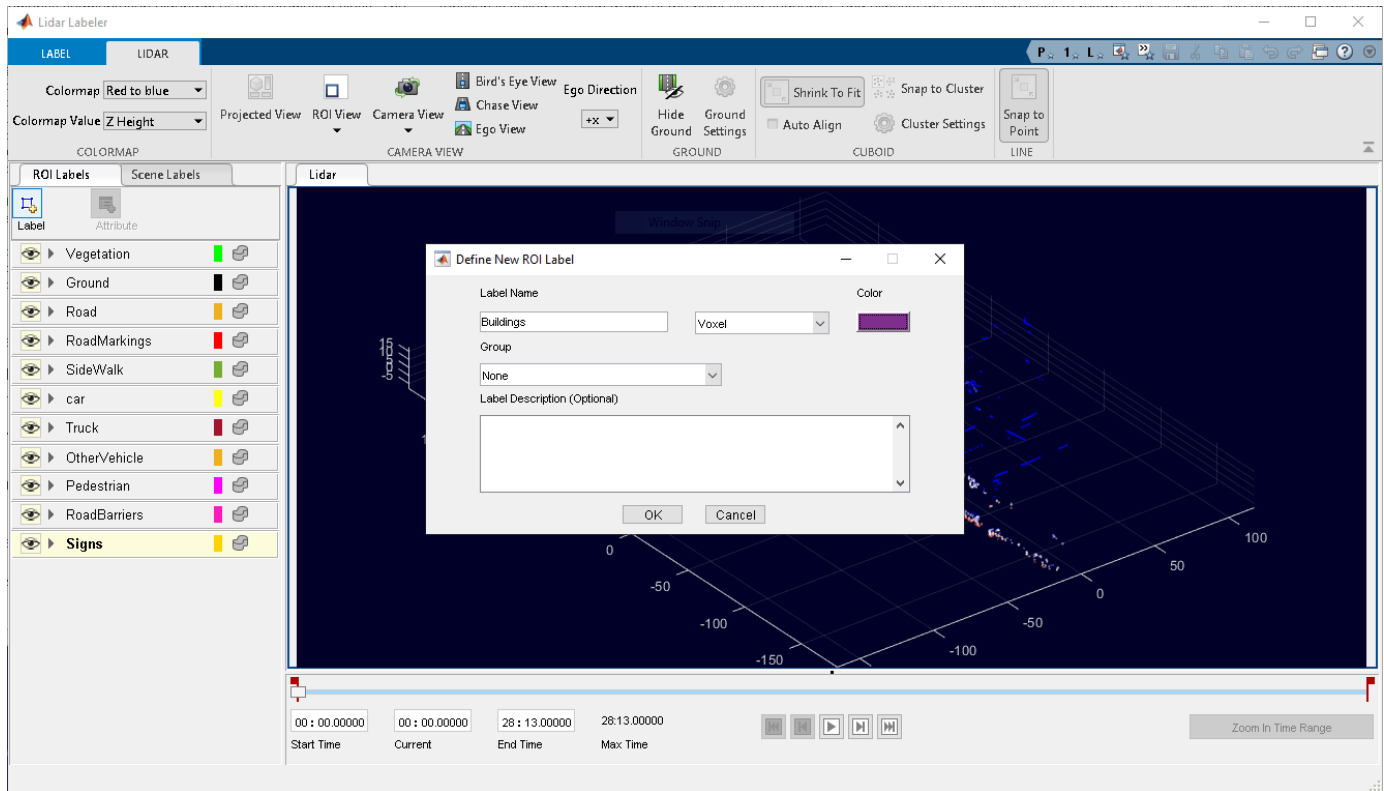

For illustration purposes, this example runs the algorithm on a subset of the PandaSet point cloud frames. Select the time range to label. Specify the first 15 seconds of the data set by entering 0 in the **Start Time** box and 15 in the **End Time** box. A pair of red flags appear on the range slider, indicating the selected time interval. The app displays the signal frames from only this interval, and applies the automation algorithm to only this interval.



Under **Select Algorithm**, select **Refresh list**. Then, select **Algorithm > Lidar Semantic Segmentation**. If you do not see this option, verify that the current working folder has a folder called +lidar/+labeler, with a file named LidarSemanticSegmentation.m in it.



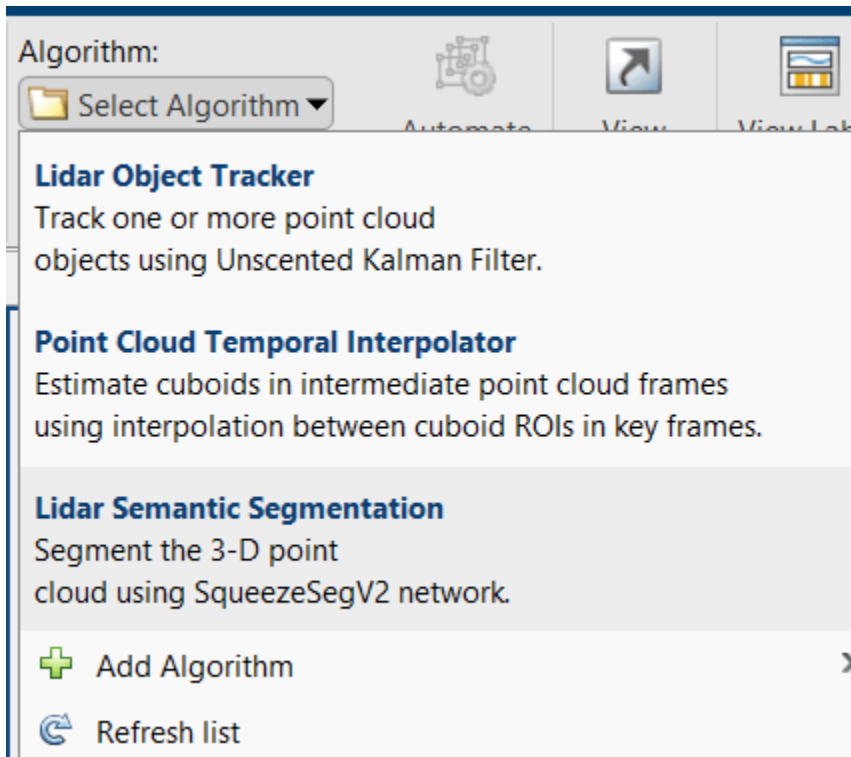

Click **Automate**. The app opens an automation session and displays directions for using the algorithm.

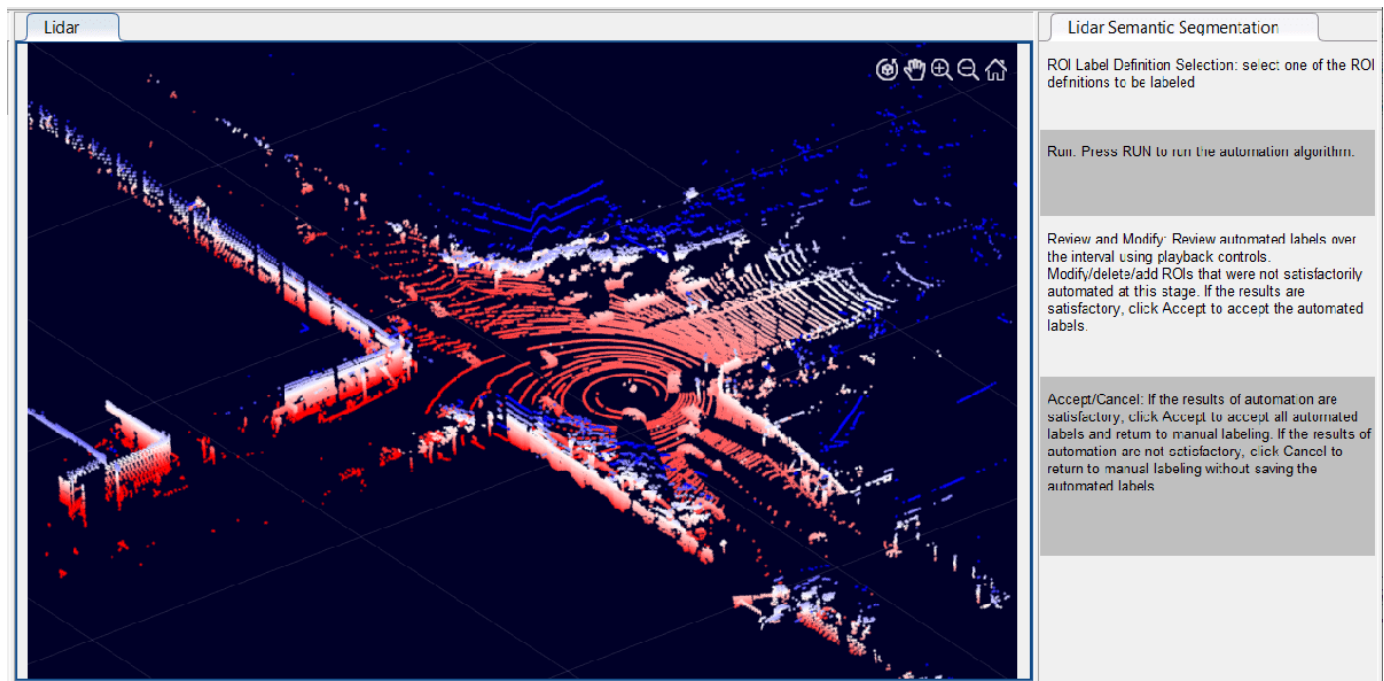

Click **Run**. The created algorithm executes on each frame of the specified sequence and segments points into the Vegetation, Ground, Road, RoadMarkings, SideWalk, Car, Truck,



OtherVehicle, Pedestrian, RoadBarriers, Signs, Buildings categories. After the app completes the automation run, use the slider or arrow keys to scroll through the sequence to locate any frames where the automation algorithm labeled points incorrectly. Use the zoom, pan, and 3-D rotation options to view and rotate the point cloud. Manually adjust the results by adding or deleting voxel annotations.

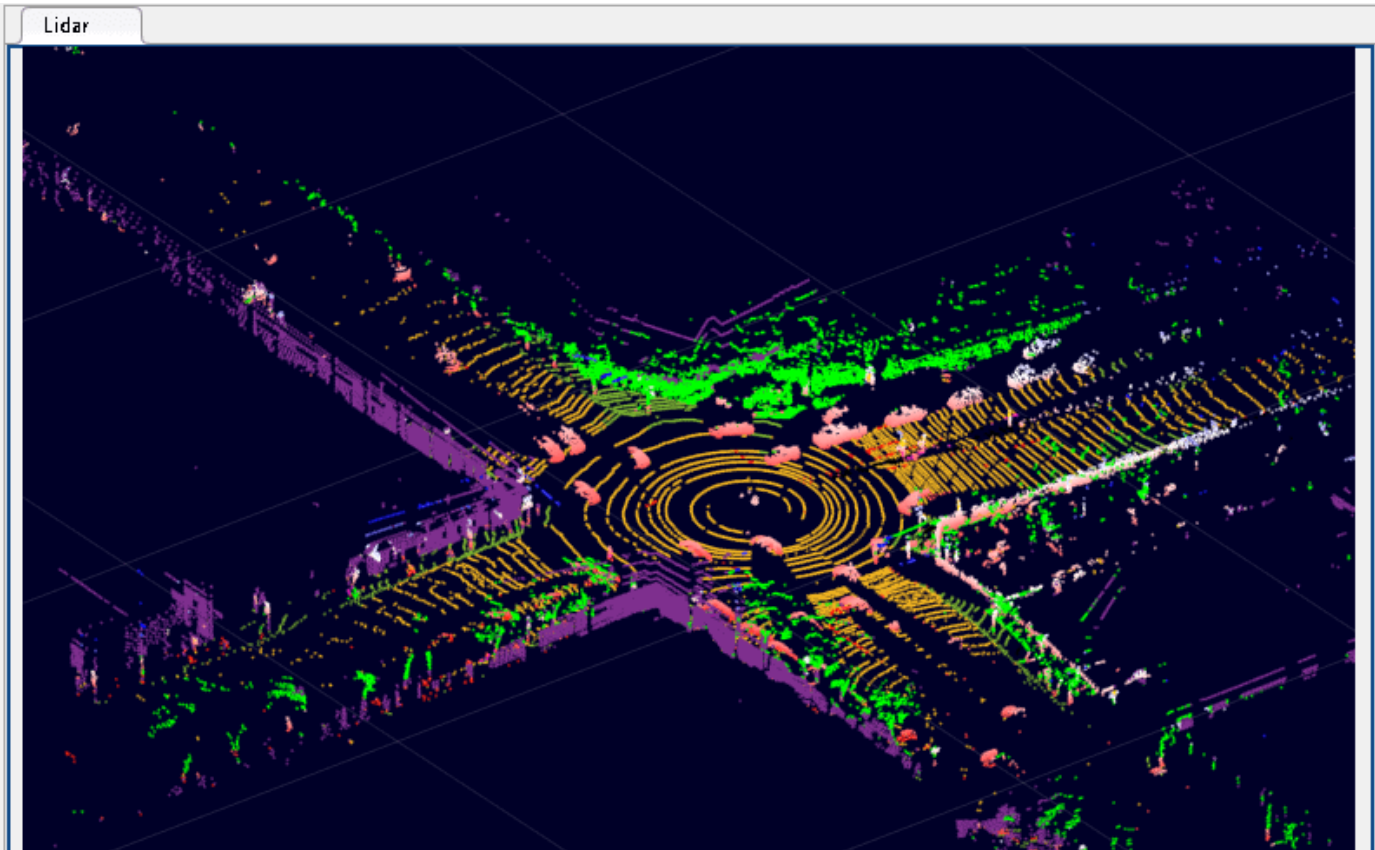

### Supporting Functions

The `helperDisplayLabelOverlaidPointCloud` function overlays the segmentation result over a 3-D organized point cloud.

```
function helperDisplayLabelOverlaidPointCloud(I,predictedResult)
    % helperDisplayLabelOverlaidPointCloud Overlay labels over point cloud object.
    % helperDisplayLabelOverlaidPointCloud(I,predictedResult)
    % displays the overlaid pointCloud object. I is the 5 channels organized
    % input image. predictedResult contains pixel labels.
    ptCloud = pointCloud(I(:,:,1:3),Intensity = I(:,:,4));
    cmap = helperPandasetColorMap;
    B = ...
        labeloverlay(uint8(ptCloud.Intensity),predictedResult,Colormap = cmap,Transparency = 0.4);
    pc = pointCloud(ptCloud.Location,Color = B);
    ax = pcshow(pc);
    set(ax,XLim = [-70 70],YLim = [-70 70])
    zoom(ax,3.5)
end
```

The `helperPandasetColorMap` function defines the colormap used by the lidar data set.

```
function cmap = helperPandasetColorMap
    cmap = [[30 30 30]; % Unlabeled
           [0 255 0]; % Vegetation
           [255 150 255]; % Ground
           [237 117 32]; % Road
           [255 0 0]; % Road Markings
           [90 30 150]; % Sidewalk
           [255 255 30]; % Car
           [245 150 100]; % Truck
           [150 60 30]; % Other Vehicle
           [255 255 0]; % Pedestrian
           [0 200 255]; % Road Barriers
           [170 100 150]; % Signs
           [255 0 255]]; % Building
    cmap = cmap./255;
end
```

The helperPointCloudToImage function converts the point cloud to a five-channel image.

```
function image = helperPointCloudToImage(ptcloud)
% helperPointCloudToImage converts the point cloud to five-channel image

image = ptcloud.Location;
image(:,:,4) = ptcloud.Intensity;
rangeData = iComputeRangeData(image(:,:,1),image(:,:,2),image(:,:,3));
image(:,:,5) = rangeData;
index = isnan(image);
image(index) = 0;
end

function rangeData = iComputeRangeData(xChannel,yChannel,zChannel)
rangeData = sqrt(xChannel.*xChannel+yChannel.*yChannel+zChannel.*zChannel);
end
```

## Create, Process, and Export Digital Surface Model from Lidar Data

This example shows how to process aerial lidar data received from an airborne lidar system into a GeoTIFF file. Import a LAZ file containing aerial lidar data, create a spatially referenced digital surface model (DSM) from the data, crop the DSM to an area of interest, and export the cropped DSM to a GeoTIFF file.

When you export a DSM to a GeoTIFF file, you also export the projected coordinate reference system (CRS) for the data. Projected CRSs associate x- and y-coordinates to locations on Earth. Specifying the projected CRS is important when creating a model because the same coordinates in different projected CRSs can refer to different locations.

### Read Aerial Lidar Data

Read 3-D point cloud data for an area near Tuscaloosa, Alabama from a LAZ file [1 on page 1-0 ]. The area includes roads, trees, and buildings.

```
lazFileName = fullfile(toolboxdir("lidar"), "lidardata", "las", "aerialLidarData.laz");  
lasReader = lasFileReader(lazFileName);  
ptCloud = readPointCloud(lasReader);
```

Display the data.

```
figure  
pcshow(ptCloud.Location)
```

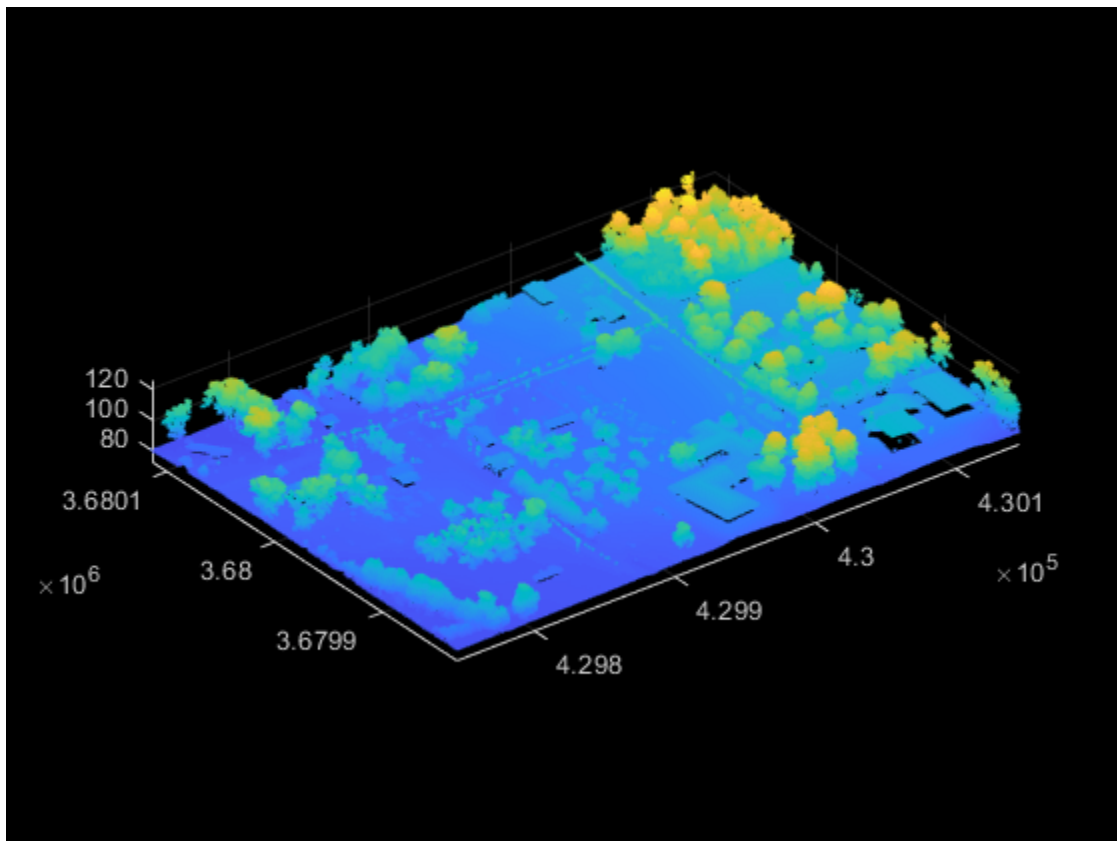

## Create DSM

A DSM includes the elevations of ground points, the elevations of natural features such as trees, and the elevations of artificial features such as buildings. Create a DSM from the point cloud data by using the `pc2dem` function. Use the maximum point from each element of the point cloud, which corresponds to the first return pulse of the lidar data, by specifying the `CornerFillMethod` as "max". The function returns an array of elevation values and the x- and y-limits of the data.

```
gridRes = 1;  
[Z,xlimits,ylimits] = pc2dem(ptCloud,gridRes,CornerFillMethod="max");
```

## Spatially Reference DSM

Spatially reference the DSM by creating a map reference object.

```
R = maprefpostings(xlimits,ylimits,size(Z))
```

```
R =  
  MapPostingsReference with properties:  
    XWorldLimits: [429745.02 430146.02]  
    YWorldLimits: [3679830.75 3680114.75]  
    RasterSize: [285 402]  
    RasterInterpretation: 'postings'  
    ColumnsStartFrom: 'south'  
    RowsStartFrom: 'west'  
    SampleSpacingInWorldX: 1  
    SampleSpacingInWorldY: 1  
    RasterExtentInWorldX: 401  
    RasterExtentInWorldY: 284  
    XIntrinsicLimits: [1 402]  
    YIntrinsicLimits: [1 285]  
    TransformationType: 'rectilinear'  
    CoordinateSystemType: 'planar'  
    ProjectedCRS: []
```

The reference object contains information such as the limits, the distance between the points, and the directions of the columns and rows. By default, the reference object assumes that columns start from the south and rows start from the west. These default values are consistent with the output of the `pc2dem` function, which creates the elevation array such that the first element represents the southwesternmost point.

The `ProjectedCRS` property of the reference object is empty, which means the DSM is not associated with a projected CRS. Read the CRS from the LAZ file and update the `ProjectedCRS` property.

```
p = readCRS(lasReader);  
R.ProjectedCRS = p;  
disp(p)  
  
projcrs with properties:  
    Name: "NAD83 / UTM zone 16N"  
    GeographicCRS: [1x1 geocrs]  
    ProjectionMethod: "Transverse Mercator"
```

```

        LengthUnit: "meter"
    ProjectionParameters: [1x1 map.crs.ProjectionParameters]

```

A projected CRS consists of a geographic CRS and several parameters that are used to transform coordinates to and from the geographic CRS. A geographic CRS consists of a datum (including a reference ellipsoid), a prime meridian, and an angular unit of measurement. View the geographic CRS and its reference ellipsoid.

```
g = p.GeographicCRS
```

```

g =
    geocrs with properties:
        Name: "NAD83"
        Datum: "North American Datum 1983"
        Spheroid: [1x1 referenceEllipsoid]
        PrimeMeridian: 0
        AngleUnit: "degree"

```

```
g.Spheroid
```

```
ans =
    referenceEllipsoid with defining properties:

```

```

        Code: 7019
        Name: 'GRS 1980'
        LengthUnit: 'meter'
        SemimajorAxis: 6378137
        SemiminorAxis: 6356752.31414036
        InverseFlattening: 298.257222101
        Eccentricity: 0.0818191910428158

```

```
and additional properties:
```

```

    Flattening
    ThirdFlattening
    MeanRadius
    SurfaceArea
    Volume

```

Display the spatially referenced DSM as an overhead surface by using the `mapshow` function.

```

figure
mapshow(Z,R,DisplayType="surface")
axis image
title("Digital Surface Model (DSM) from Aerial Lidar Data")

```

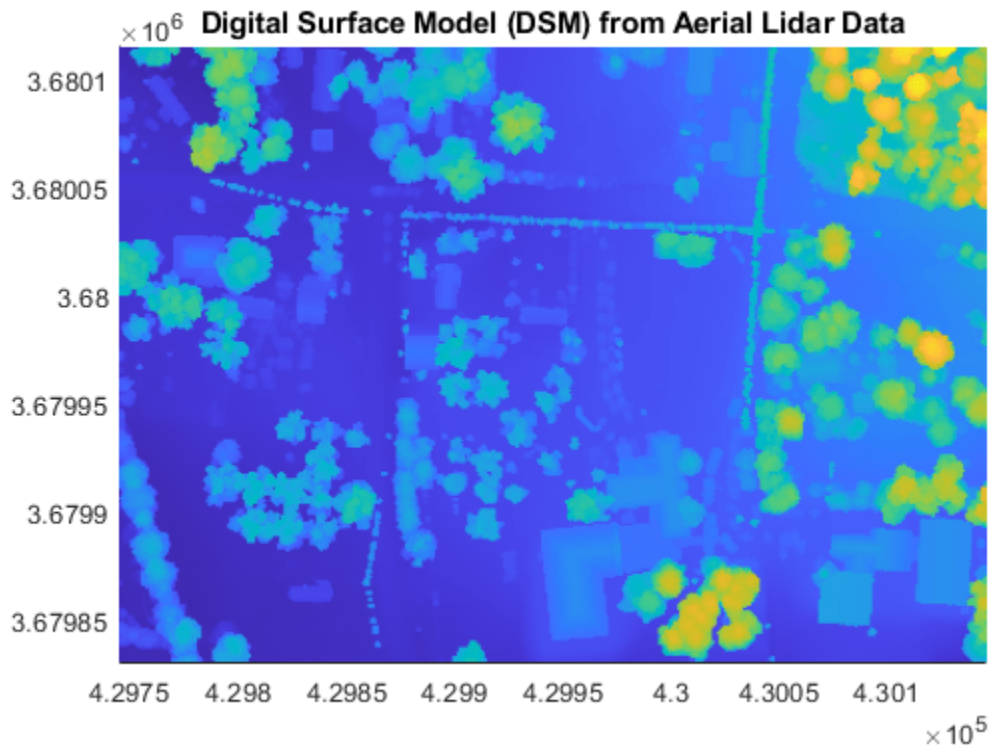

### Crop DSM to Region of Interest

Represent the DSM region as a polygon by using a `mappolyshape` object. Update the `ProjectedCRS` property to match the CRS of the DSM.

```
bboxx = xlims([1 1 2 2 1]);
bboxxy = ylims([1 2 2 1 1]);
bboxshape = mappolyshape(bboxxx,bboxxy);
bboxshape.ProjectedCRS = p;
```

View the region using satellite imagery. You can visually confirm that the satellite imagery aligns with the DSM visualization created using the `mapshow` function.

```
regioncolors = lines(2);
geoplot(bboxshape, ...
    EdgeColor=regioncolors(1,:), ...
    FaceAlpha=0.2, ...
    LineWidth=2, ...
    DisplayName="Aerial Lidar Data Region")
hold on
geobasemap satellite
legend
```

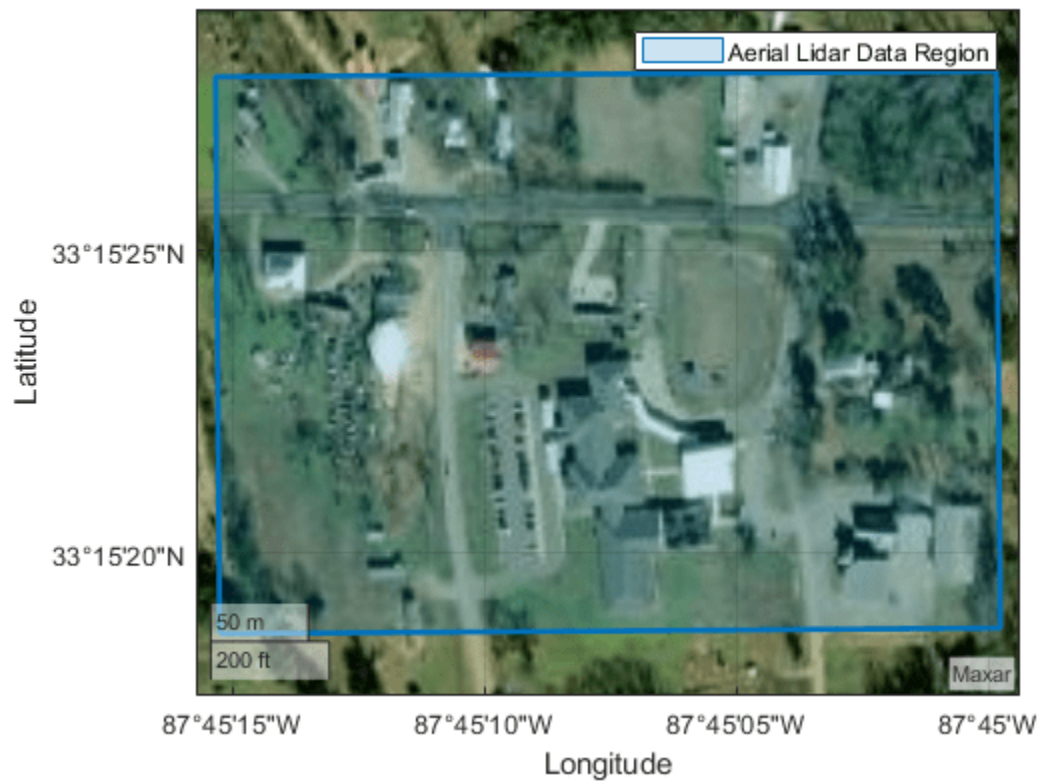

Select and display a region of interest. To use a predefined region that is bounded by roads on the east, north, and west, specify `interactivelySelectPoints` as `false`. Alternatively, you can interactively select four points that define a region by specifying `interactivelySelectPoints` as `true`.

```
interactivelySelectPoints = false;
if interactivelySelectPoints
    [cropbboxlat,cropbboxlon] = ginput(4); %#ok<UNRCH>
else
    cropbboxlat = [33.2571550; 33.2551982; 33.2551982; 33.2571125];
    cropbboxlon = [-87.7530648; -87.7530139; -87.7509086; -87.7509086];
end
cropbboxlat(end+1) = cropbboxlat(1);
cropbboxlon(end+1) = cropbboxlon(1);
cropbboxshape = geoplyshape(cropbboxlat,cropbboxlon);

geoplot(cropbboxshape, ...
    EdgeColor=regioncolors(2,:), ...
    FaceAlpha=0.2, ...
    LineWidth=2, ...
    DisplayName="Selected Region of Interest")
```





Transform the latitude and longitude limit coordinates for the region to  $x$ - and  $y$ -limit coordinates. The geographic CRS underlying the satellite basemap is WGS84, while the geographic CRS underlying the DSM data is NAD83. NAD83 and WGS84 are similar, but not identical. As a result, there can be discrepancies in coordinates between the satellite imagery and DSM.

```
[cropbboxx,cropbboxxy] = projfwd(p,cropbboxlat(:),cropbboxlon(:));
```

Create the crop limits by finding the bounds of the  $x$ - and  $y$ -coordinates.

```
[cropxlimmin,cropxlimmax] = bounds(cropbboxx);
cropxlimits = [cropxlimmin cropxlimmax];
[cropylimmin,cropylimmax] = bounds(cropbboxxy);
cropylimits = [cropylimmin cropylimmax];
```

Create a new spatially referenced DSM that contains data within the region of interest.

```
[Zcrop,Rcrop] = mapcrop(Z,R,cropxlimits,cropylimits);
```

### Export DSM to GeoTIFF File

Write the cropped DSM to a GeoTIFF file called `lidardsm.tif`. Specify the projected CRS by using the `CoordRefSysCode` argument. The metadata for the LAZ file [1 on page 1-0 ] indicates the projected CRS is UTM Zone 16N, specified by EPSG authority code 26916.

```
datafile = "lidardsm.tif";
epsgCode = 26916;
geotiffwrite(datafile,Zcrop,Rcrop,CoordRefSysCode=epsgCode)
```



You can also find the authority code by displaying the well-known text (WKT) string for the projected CRS. For this WKT, the authority code is in the last line.

```
wktstring(p, "Format", "formatted")

ans =
  "PROJCRS["NAD83 / UTM zone 16N",
    BASEGEOGCRS["NAD83",
      DATUM["North American Datum 1983",
        ELLIPSOID["GRS 1980",6378137,298.257222101,
          LENGTHUNIT["metre",1]]],
      PRIMEM["Greenwich",0,
        ANGLEUNIT["degree",0.0174532925199433]],
      ID["EPSG",4269]],
    CONVERSION["UTM zone 16N",
      METHOD["Transverse Mercator",
        ID["EPSG",9807]],
      PARAMETER["Latitude of natural origin",0,
        ANGLEUNIT["degree",0.0174532925199433],
        ID["EPSG",8801]],
      PARAMETER["Longitude of natural origin",-87,
        ANGLEUNIT["degree",0.0174532925199433],
        ID["EPSG",8802]],
      PARAMETER["Scale factor at natural origin",0.9996,
        SCALEUNIT["unity",1],
        ID["EPSG",8805]],
      PARAMETER["False easting",500000,
        LENGTHUNIT["metre",1],
        ID["EPSG",8806]],
      PARAMETER["False northing",0,
        LENGTHUNIT["metre",1],
        ID["EPSG",8807]]],
    CS[Cartesian,2],
      AXIS["easting",east,
        ORDER[1],
        LENGTHUNIT["metre",1]],
      AXIS["northing",north,
        ORDER[2],
        LENGTHUNIT["metre",1]],
    ID["EPSG",26916]]"
```

One way to validate the GeoTIFF file is to return information about the file as a `RasterInfo` object. For example, verify that the projected CRS is in the file by querying the `CoordinateReferenceSystem` property of the `RasterInfo` object.

```
info = georasterinfo(datafile);
info.CoordinateReferenceSystem

ans =
  projcrs with properties:
      Name: "NAD83 / UTM zone 16N"
      GeographicCRS: [1x1 geocrs]
      ProjectionMethod: "Transverse Mercator"
      LengthUnit: "meter"
      ProjectionParameters: [1x1 map.crs.ProjectionParameters]
```

Another way to validate the GeoTIFF file is by displaying it. Read the new DSM as an array and a reference object by using the `readgeoraster` function. Then, display the DSM.

```
[Z2,R2] = readgeoraster(datafile);  
  
figure  
mapshow(Z2,R2,DisplayType="surface")  
axis image  
title("Cropped DSM from Aerial Lidar Data")
```

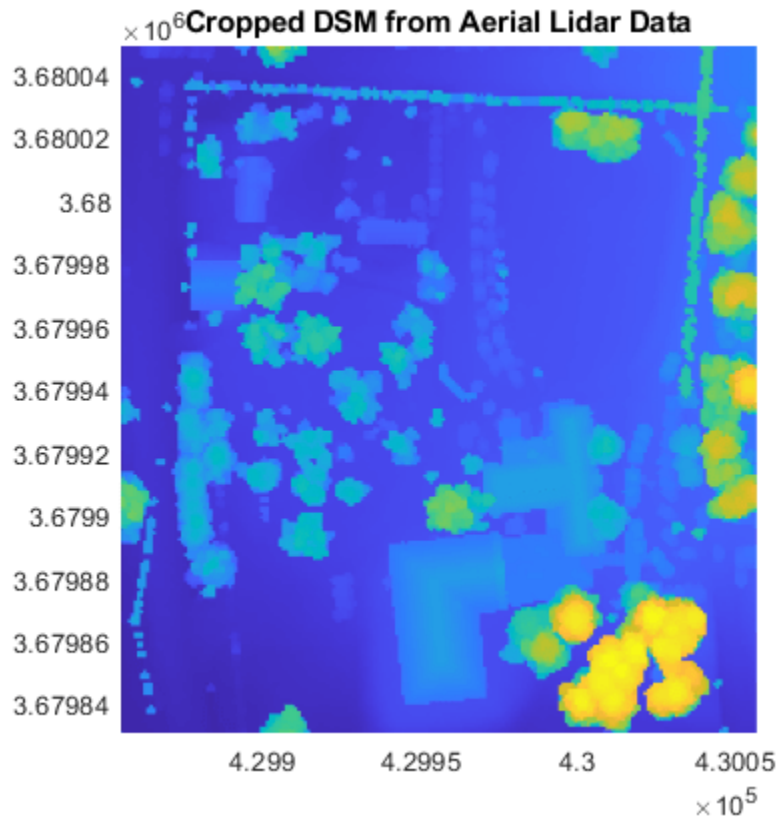

You can use the GeoTIFF file in other applications that import GIS data. For example, RoadRunner enables you to add elevation data from GeoTIFF files to scenes.

## References

[1] OpenTopography. "Tuscaloosa, AL: Seasonal Inundation Dynamics And Invertebrate Communities," 2011. <https://doi.org/10.5069/G9SF2T3K>.

## Multi-Lidar Calibration

This example shows how to calibrate multiple 3-D lidar sensors mounted on a vehicle to estimate a relative transformation between them. Traditional methods, such as marker-based registration, are difficult when the lidar sensors have a negligible overlap between their fields of view (FOVs). The calibration also becomes more difficult as the number of lidar sensors increases. This example demonstrates the use of the trajectories of individual lidar sensors to estimate the transformation between them. This method of calibration is also known as *hand-eye calibration*.

The use of multiple lidar sensors on an autonomous vehicle helps to remove blind spots, increases redundancy, and enables high-resolution map creation. To extract meaningful information from multiple lidar sensors, you can fuse the data using the transformation between them. Fusing multiple lidars can be challenging because of variations in resolution between different lidar sensors. This example also demonstrates how to create a high-resolution point cloud map by fusing the point clouds from multiple lidar sensors.

This example uses synthetic input data generated using the Unreal Engine® by Epic Games®. The figure shows the configuration of the sensors mounted on the vehicle.



### Load Vehicle Trajectory

The generated data simulates a vehicle on a predefined trajectory in an urban road setting. For details on how to interactively select a sequence of waypoints from a scene and generate vehicle trajectories, see the “Select Waypoints for Unreal Engine Simulation” (Automated Driving Toolbox) example. Use the `helperShowSceneImage` helper function to visualize the path the vehicle follows while collecting the data.

```
% Load reference path for recorded drive segment
xData = load('refPosesX.mat');
yData = load('refPosesY.mat');
yawData = load('refPosesT.mat');

% Set up workspace variables used by model
refPosesX = xData.refPosesX;
refPosesY = yData.refPosesY;
refPosesT = yawData.refPosesT;

if ~ispc
    error(['3D Simulation is only supported on Microsoft', ...
        char(174), ' Windows', char(174), '.']);
end
```

```
sceneName = "VirtualMcity";  
hScene = figure;  
helperShowSceneImage(sceneName)  
hold on  
scatter(refPosesX(:,2),refPosesY(:,2),7,'filled')  
  
% Adjust axes limits  
xlim([-50 100])  
ylim([-50 75])
```

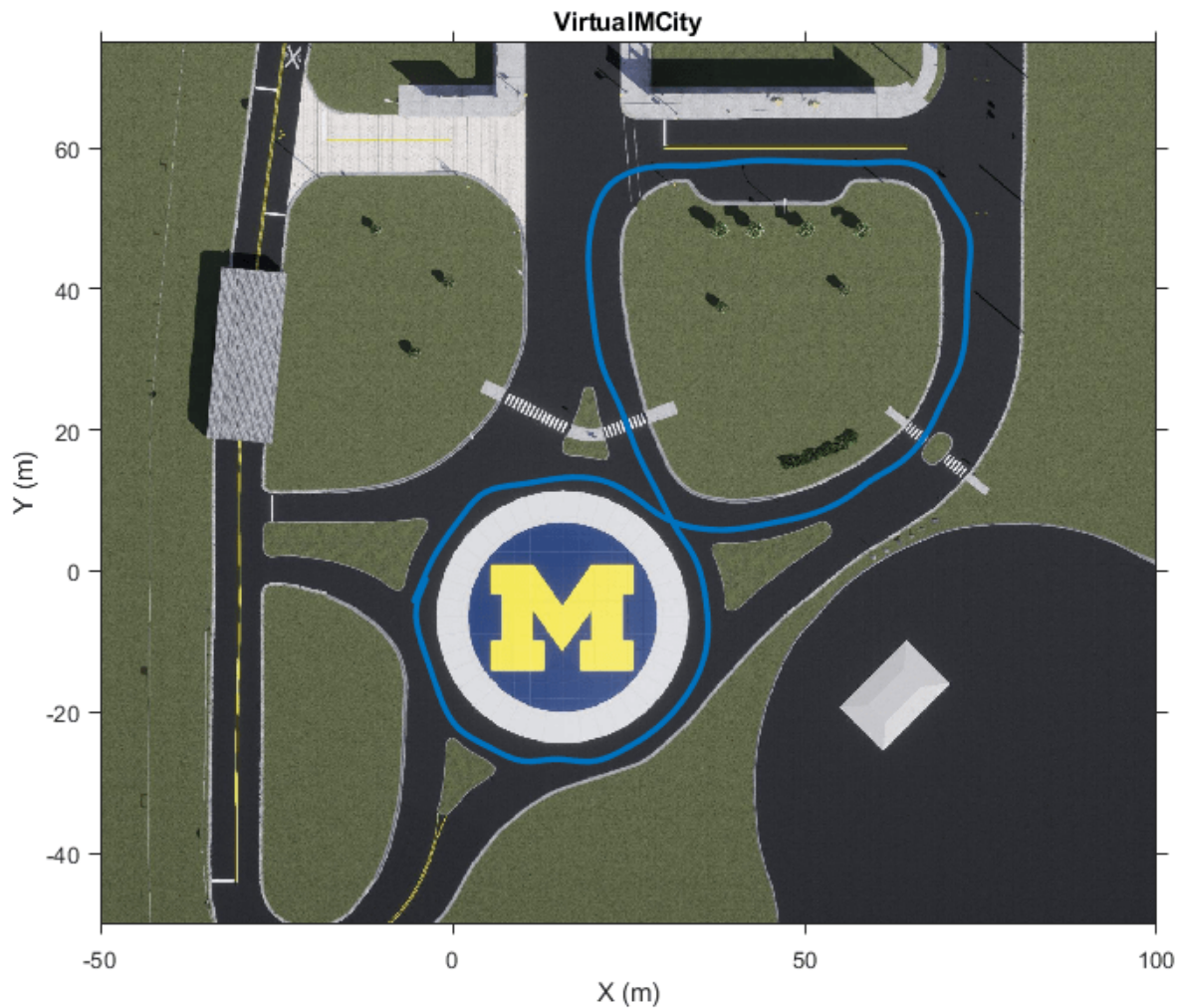

### Record Synthetic Data

The MultiLidarSimulation Simulink model is configured for the Virtual Mcity (Automated Driving Toolbox) 3-D environment using the Simulation 3D Scene Configuration (Automated Driving Toolbox)

block. A vehicle of type box truck is configured in the scene using the Simulation 3D Vehicle with Ground Following (Automated Driving Toolbox) block. The vehicle has two lidar sensors mounted on it using the Simulation 3D Lidar (Automated Driving Toolbox) block. The two lidars are mounted such that one lidar sensor is mounted at the front bumper and the other at the rear bumper. The mounting position of the lidar sensor can be adjusted using the **Mounting** tab in the simulation block.

```
modelName = 'MultiLidarSimulation';
open_system(modelName)
```

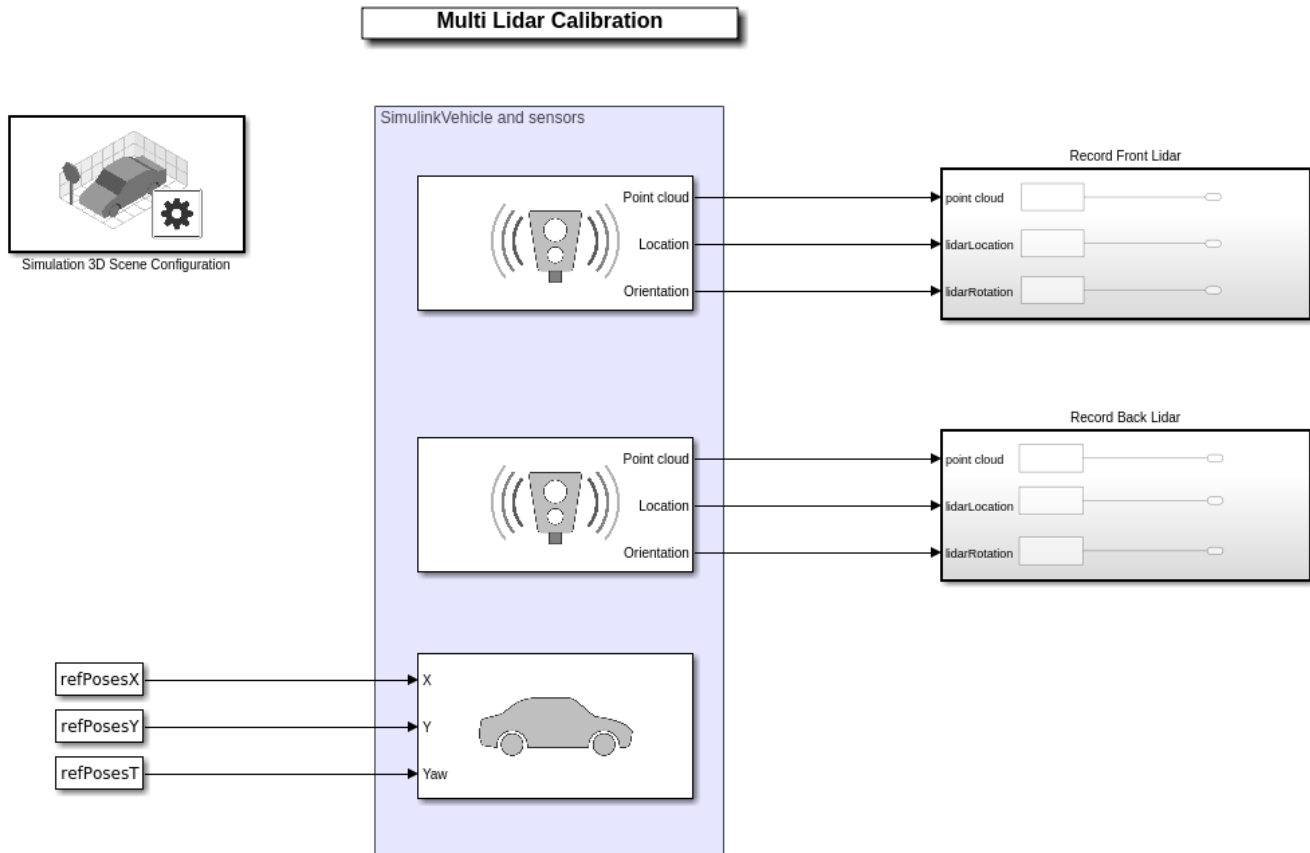

Copyright 2021 The MathWorks Inc.

The model records synthetic lidar data and saves it to the workspace.

```
% Update simulation stop time to end when reference path is completed
simStopTime = refPosesX(end,1);
set_param(gcs,StopTime=num2str(simStopTime));

% Run the simulation
simOut = sim(modelName);
```

### Extract Lidar Odometry

There are several simultaneous localization and mapping (SLAM) methods that estimate the odometry from lidar data by registering successive point cloud frames. You can further optimize the relative transform between the frames through loop closure detection. For more details on how to

generate a motion trajectory using the NDT-based registration method, see the “Design Lidar SLAM Algorithm Using Unreal Engine Simulation Environment” (Automated Driving Toolbox) example. For this example, use the `helperExtractLidarOdometry` helper function to generate the motion trajectory as a `pcviewset` object to the simulation output `simOut`.

```
% Front lidar translation and rotation
frontLidarTranslations = simOut.lidarLocation1.signals.values;
frontLidarRotations = simOut.lidarRotation1.signals.values;

% Back lidar translation and rotation
backLidarTranslations = simOut.lidarLocation2.signals.values;
backLidarRotations = simOut.lidarRotation2.signals.values;

% Extract point clouds from the simulation output
[frontLidarPtCloudArr,backLidarPtCloudArr] = helperExtractPointCloud(simOut);

% Extract lidar motion trajectories
frontLidarVset = helperExtractLidarOdometry(frontLidarTranslations,frontLidarRotations, ...
    frontLidarPtCloudArr);
backLidarVset = helperExtractLidarOdometry(backLidarTranslations,backLidarRotations, ...
    backLidarPtCloudArr);
```

The `helperVisualizeLidarOdometry` helper function visualizes the accumulated point cloud map with the motion trajectory overlaid on it.

```
% Extract absolute poses of lidar sensor
frontLidarAbsPos = frontLidarVset.Views.AbsolutePose;
backLidarAbsPos = backLidarVset.Views.AbsolutePose;

% Visualize front lidar point cloud map and trajectory
figure
plot(frontLidarVset)
hold on
plot(backLidarVset)
legend({'Front Lidar Trajectory','Back Lidar Trajectory'})
title("Lidar Trajectory")
view(2)
```

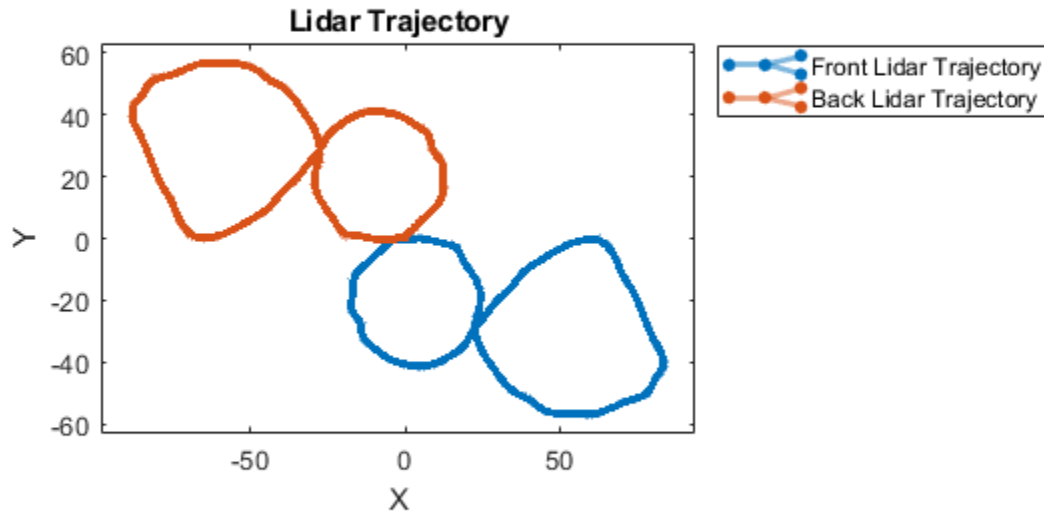

The trajectories of the two lidar sensors appear to be shifted by 180 degrees. This is because the lidar sensors are configured facing in opposite directions in the Simulink model.

### Align Lidar Trajectory

General registration-based methods, using point clouds, often fail to calibrate lidar sensors with nonoverlapping or negligible-overlap fields of view because they lack of sufficient corresponding features. To overcome this challenge, use the motion of the vehicle for registration. Because of the rigid nature of the vehicle and the sensors mounted on it, the motion of each sensor correlates to the relative transformation between the sensors. To extract this relative transformation, formulate the solution to align lidar trajectory as a hand-eye calibration that involves solving the equation  $AX = XB$ , where  $A$  and  $B$  are successive poses of the two sensors,  $A$  and  $B$ . You can further decompose this equation into its rotation and translation components.

$$R_{a_{k-1}}^{a_k} * R_b^a = R_b^a * R_{b_{k-1}}^{b_k}$$

$$R_{a_{k-1}}^{a_k} * t_b^a + t_{a_{k-1}}^{a_k} = R_b^a * t_a$$

$R_{a_{k-1}}^{a_k}$ ,  $t_{a_{k-1}}^{a_k}$  are the rotation and translation components of sensor A from timestamp  $k - 1$  to  $k$ .  $R_b^a$ ,  $t_b^a$  are the rotation and translation components of sensor A relative to sensor B. This figure shows the relationship between the relative transformation and the successive poses between the two sensors.

$T_{a_{k-1}}^{a_k}$ ,  $T_{b_{k-1}}^{b_k}$  is total transformation of sensors A, B and  $T_b^a$  is the relative transformation.

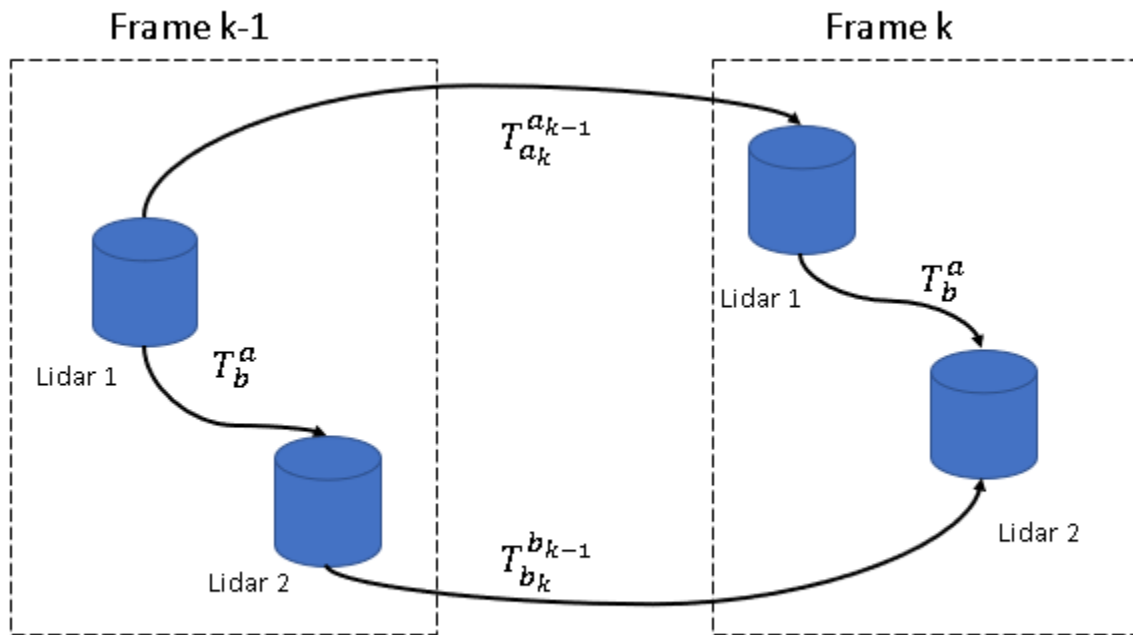

## Transformation between two consecutive frames

There are multiple ways to solve the equations for rotation and translation[1 on page 1-0 ]. Use the `helperEstimateHandEyeTransformation` helper function attached as a supporting file to this example, to estimate the initial transformation between the two lidar sensors as a `rigid3d` object. To extract the rotation component of the equation, the function converts the rotation matrices into a quaternion form restructured as a linear system. The function finds the closed-form solution of this linear system using singular value decomposition[2 on page 1-0 ].

```
tformInit = helperEstimateHandEyeTransformation(backLidarAbsPos, frontLidarAbsPos);
```

### Transformation Refinement

To further refine the transformation, use a registration-based method. Input the translation of each lidar sensor from their respective trajectories to the registration. Use the `helperExtractPosFromTform` helper function to convert the trajectories of the sensors into `showPointCloud` objects. For registration, use the `pregistericp` function with the calculated rotation component `tformInit` as your initial transformation.

```
% Extract the translation of each sensor in the form of a point cloud object
frontLidarTrans = helperExtractPosFromTform(frontLidarAbsPos);
backLidarTrans = helperExtractPosFromTform(backLidarAbsPos);
```

```
% Register the trajectories of the two sensors
tformRefine = pregistericp(backLidarTrans, frontLidarTrans, ...
    'InitialTransform', tformInit, Metric='pointToPoint');
```

Note that the accuracy of the calibration depends on how accurately you estimate the motion of each sensor. To simplify the computation, the motion estimate for the vehicle assumes the ground plane is flat. Because of this assumption, the estimation loses one degree of freedom along the Z-axis. You can estimate the transformation along the Z-axis by using the ground plane detection method[3 on page



1-0 ]. Use the `pcfitplane` function to estimate the ground plane from the point clouds of the two lidar sensors. The function estimates the height of each sensor from the detected ground planes of the two lidar sensors. Use the `helperExtractPointCloud` helper function to extract a `pointCloud` object array from the simulation output `simOut`.

```
% Maximum allowed distance between the ground plane and inliers
maxDist = 0.8;

% Reference vector for ground plane
refVecctor = [0 0 1];

% Fit plane on the a single point cloud frame
frame = 2;
frontPtCloud = frontLidarPtCloudArr(2);
backPtCloud = backLidarPtCloudArr(2);

[~,frontLidarInliers,~] = pcfitplane(frontPtCloud,maxDist,refVecctor);
[~,backLidarInliers,~] = pcfitplane(backPtCloud,maxDist,refVecctor);

% Extract relative translation between Z-axis
frontGroundPlane = select(frontPtCloud,frontLidarInliers);
backGroundPlane = select(backPtCloud,backLidarInliers );

frontGroundPts = frontGroundPlane.Location;
backGroundPlane = backGroundPlane.Location;

% Compute the difference between mean values of the extracted ground planes
zRel = mean(frontGroundPts(:,3)) - mean(backGroundPlane(:,3));

% Update the initial transformation with the estimated relative translation
% in the Z-axis
tformRefine.Translation(3) = zRel;
```

### Fuse point cloud

After obtaining the relative transformation between the two lidar sensors, fuse the point clouds from the two lidar sensors. Then fuse the fused point cloud sequentially to create a point cloud map of the data from the two lidar sensors. This figure shows the point cloud fusion method of point cloud map creation.

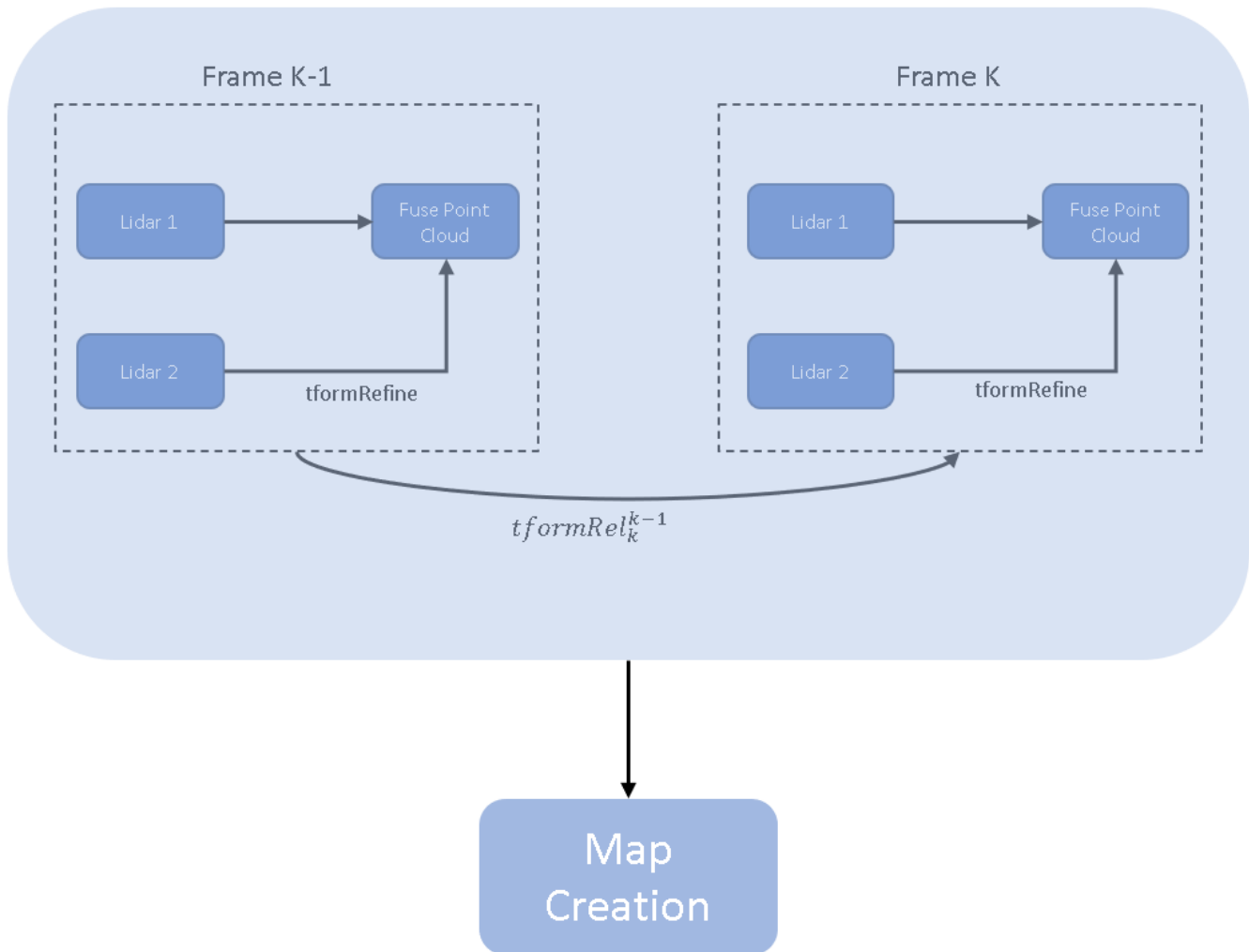

Use the `helperVisualizedFusedPtCloud` helper function to fuse the point clouds from the two lidar sensors, overlaid with the fused trajectory after calibration. From the fused point cloud map, you can visually infer the accuracy of the calibration.

```
helperVisualizedFusedPtCloud(backLidarVset, frontLidarVset, tformRefine)
```

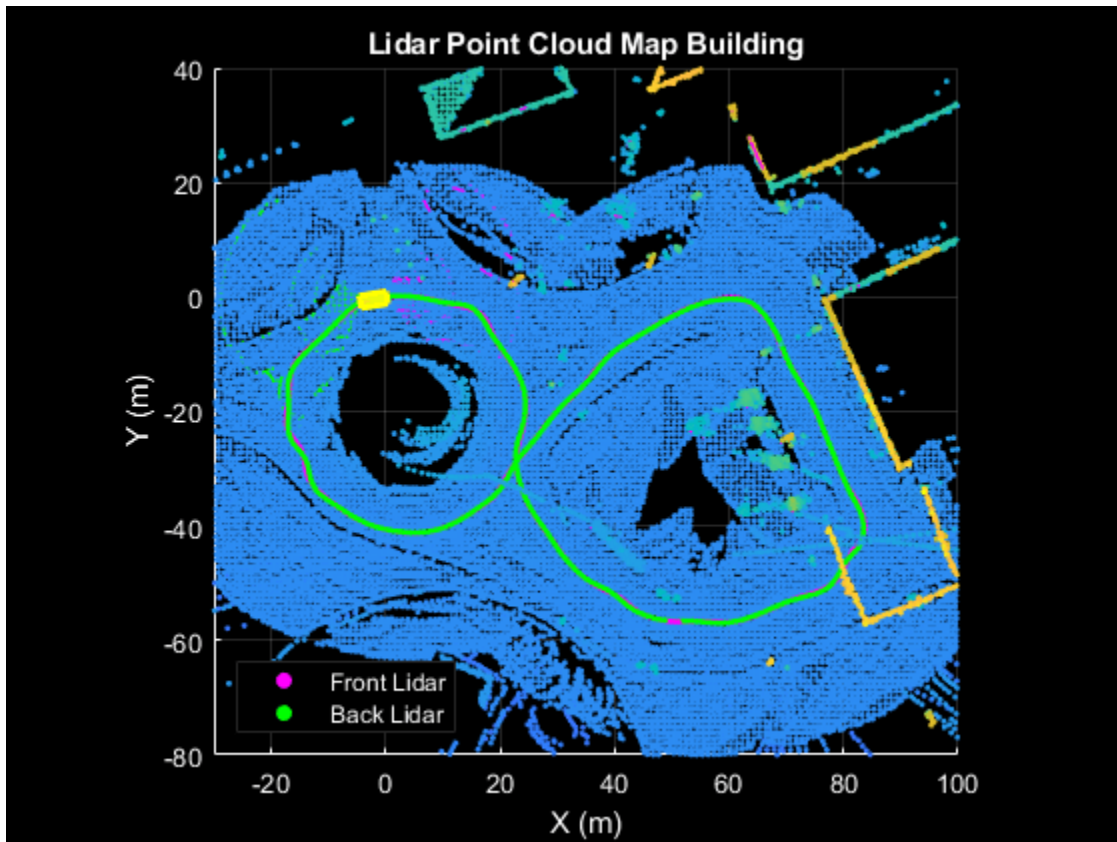

## Results

The accuracy of the calibration is measured with respect to the ground truth transformation obtained from the mounting location of the sensors. The Sport Utility Vehicle (Vehicle Dynamics Blockset) documentation page provides the details of the mounting position of the two lidar sensors. The relative transformation between the two lidar sensors is loaded from the `gTruth.mat` file.

```
gt = load('gTruth.mat');
tformGt = gt.gTruth;

% Compute the translation error along the x-, y-, and z-axes
transError = tformRefine.Translation - tformGt.Translation;
fprintf("Translation error along x in meters: %d",transError(1));

Translation error along x in meters: 8.913606e-03

fprintf("Translation error along y in meters: %d",transError(2));

Translation error along y in meters: 6.720094e-03

fprintf("Translation error along z in meters: %d",transError(3));

Translation error along z in meters: 2.294692e-02

% Compute the translation error along the x-, y-, and z-axes
rEst = rad2deg(rotm2eul(tformRefine.Rotation));
rGt = rad2deg(rotm2eul(tformGt.Rotation));
rotError = rEst - rGt;
fprintf("Rotation error along x in degrees: %d",rotError(3));
```

```
Rotation error along x in degrees: -4.509040e-04
fprintf("Rotation error along y in degrees: %d",rotError(2));
Rotation error along y in degrees: 2.201822e-05
fprintf("Rotation error along z in degrees: %d",rotError(1));
Rotation error along z in degrees: 2.545250e-02
```

### Supporting Functions

`helperExtractPointCloud` extracts an array of `pointCloud` objects from a simulation output.

```
function [ptCloudArr1,ptCloudArr2] = helperExtractPointCloud(simOut)

% Extract signal
ptCloudData1 = simOut.ptCloudData1.signals.values;
ptCloudData2 = simOut.ptCloudData2.signals.values;

numFrames = size(ptCloudData1,4);

% Create a pointCloud array
ptCloudArr1 = pointCloud.empty(0,numFrames);
ptCloudArr2 = pointCloud.empty(0,numFrames);

for n = 1:size(ptCloudData1,4)
    ptCloudArr1(n) = pointCloud(ptCloudData1(:,:,,n));
    ptCloudArr2(n) = pointCloud(ptCloudData2(:,:,,n));
end
end
```

`helperExtractLidarOdometry` extracts the total transformation of the sensors.

```
function vSet = helperExtractLidarOdometry(location,theta,ptCloud)

numFrames = size(location, 3);
vSet = pcviewset;
tformRigidAbs = rigid3d;
yaw = theta(:,3,1);
rot = [cos(yaw) sin(yaw) 0; ...
       -sin(yaw) cos(yaw) 0; ...
       0 0 1];

% Use first frame as reference frame
tformOrigin = rigid3d(rot,location(:,:,1));
vSet = addView(vSet,1,tformRigidAbs,PointCloud=ptCloud(1));
for i = 2:numFrames
    yawCurr = theta(:,3,i);
    rotatCurr = [cos(yawCurr) sin(yawCurr) 0; ...
                 -sin(yawCurr) cos(yawCurr) 0; ...
                 0 0 1];

    transCurr = location(:,:,i);
    tformCurr = rigid3d(rotatCurr,transCurr);

% Absolute pose
tformRigidAbs(i) = rigid3d(tformCurr.T * tformOrigin.invert.T);
vSet = addView(vSet,i,tformRigidAbs(i),PointCloud=ptCloud(i));
```

```

    % Transform between frame k-1 and k
    relPose = rigid3d(tformRigidAbs(i-1).T * tformRigidAbs(i).invert.T);
    vSet = addConnection(vSet,i-1,i,relPose);
end
end

```

helperVisualizedFusedPtCloud visualizes a point cloud map from the fusion of two lidar sensors.

```

function helperVisualizedFusedPtCloud(movingVset,baseVset,tform)
hFig = figure(Name='Point Cloud Fusion', ...
    NumberTitle='off');
ax = axes(Parent = hFig);

% Create a scatter object for map points
scatterPtCloudBase = scatter3(ax,NaN,NaN,NaN, ...
    2,'magenta','filled');
hold(ax, 'on');
scatterPtCloudMoving = scatter3(ax,NaN,NaN,NaN, ...
    2,'green','filled');
scatterMap = scatter3(ax,NaN,NaN,NaN, ...
    5,'filled');

% Create a scatter object for relative positions
positionMarkerSize = 5;
scatterTrajectoryBase = scatter3(ax,NaN,NaN,NaN, ...
    positionMarkerSize,'magenta','filled');
scatterTrajectoryMoving = scatter3(ax,NaN,NaN,NaN, ...
    positionMarkerSize,'green','filled');
hold(ax,'off');

% Set background color
ax.Color = 'k';
ax.Parent.Color = 'k';

% Set labels
xlabel(ax,'X (m)')
ylabel(ax,'Y (m)')

% Set grid colors
ax.GridColor = 'w';
ax.XColor = 'w';
ax.YColor = 'w';

% Set aspect ratio for axes
axis(ax,'equal')
xlim(ax, [-30 100]);
ylim(ax, [-80 40]);
title(ax,'Lidar Point Cloud Map Building',Color=[1 1 1])

ptCloudsMoving = movingVset.Views.PointCloud;
absPoseMoving = movingVset.Views.AbsolutePose;

ptCloudsBase = baseVset.Views.PointCloud;
absPoseBase = baseVset.Views.AbsolutePose;

numFrames = numel(ptCloudsMoving);

```

```

% Extract relative positions from the absolute poses
relPositionsMoving = arrayfun(@(poseTform) transformPointsForward(poseTform, ...
    [0 0 0]),absPoseMoving,UniformOutput=false);
relPositionsMoving = vertcat(relPositionsMoving{:});

relPositionsBase = arrayfun(@(poseTform) transformPointsForward(poseTform, ...
    [0 0 0]),absPoseBase,UniformOutput=false);
relPositionsBase = vertcat(relPositionsBase{:});

set(scatterTrajectoryBase,'XData',relPositionsMoving(1,1),'YData', ...
    relPositionsMoving(1,2),'ZData',relPositionsMoving(1,3));
set(scatterTrajectoryMoving,'XData',relPositionsBase(1,1),'YData', ...
    relPositionsBase(1,2),'ZData',relPositionsBase(1,3));

% Set legend
legend(ax, {'Front Lidar','Back Lidar'}, ...
    Location='southwest',TextColor='w')
skipFrames = 5;
for n = 2:skipFrames:numFrames
    pc1 = pctransform(removeInvalidPoints(ptCloudsMoving(n)),absPoseMoving(n));
    pc2 = pctransform(removeInvalidPoints(ptCloudsBase(n)),absPoseBase(n));
    % Transform moving point cloud to the base
    pc1 = pctransform(pc1,tform);

    % Create a point cloud map and merge point clouds from the sensors
    baseMap = pcalign(ptCloudsBase(1:n),absPoseBase(1:n),1);
    movingMap = pcalign(ptCloudsMoving(1:n),absPoseMoving(1:n),1);

    movingMap = pctransform(movingMap,tform);
    map = pcmerge(baseMap,movingMap,0.1);

    % Transform the position of the moving sensor to the base
    xyzTransformed = [relPositionsMoving(1:n,1),relPositionsMoving(1:n,2), ...
        relPositionsMoving(1:n,3)]*tform.Rotation + tform.Translation;

    % Plot current point cloud of individual sensor with respect to the ego
    % vehicle
    set(scatterPtCloudBase,'XData',pc2.Location(:,1),'YData', ...
        pc2.Location(:,2),'ZData',pc2.Location(:,3));
    set(scatterPtCloudMoving,'XData',pc1.Location(:,1),'YData', ...
        pc1.Location(:,2),'ZData',pc1.Location(:,3))

    % Plot fused point cloud map
    set(scatterMap,'XData',map.Location(:,1),'YData', ...
        map.Location(:,2),'ZData',map.Location(:,3),'CData',map.Location(:,3));

    % Plot trajectory
    set(scatterTrajectoryBase,'XData',relPositionsBase(1:n,1),'YData', ...
        relPositionsBase(1:n,2),'ZData',relPositionsBase(1:n,3));
    set(scatterTrajectoryMoving,'XData',xyzTransformed(:,1),'YData', ...
        xyzTransformed(:,2),'ZData',xyzTransformed(:,3));

    % Draw ego vehicle assuming the dimensions of a sports utility vehicle
    eul = rotm2eul(absPoseBase(n).Rotation');
    theta = rad2deg(eul);
    t = xyzTransformed(end,:) + [4.774 0 0]/2*(absPoseBase(n).Rotation);
    pos = [t 4.774 2.167 1.774 theta(2) theta(3) theta(1)];
    showShape('cuboid',pos,Color='yellow',Parent=ax,Opacity=0.9);

```

```

    view(ax,2)
    drawnow limitrate
end
end

```

helperExtractPosFromTform converts translation from a pose to a pointCloud object.

```

function ptCloud = helperExtractPosFromTform(pose)
numFrames = numel(pose);
location = zeros(numFrames,3);
for i = 1:numFrames
    location(i,:) = pose(i).Translation;
end
ptCloud = pointCloud(location);
end

```

## References

- [1] Shah, Mili, Roger D. Eastman, and Tsai Hong. 'An Overview of Robot-Sensor Calibration Methods for Evaluation of Perception Systems'. In *Proceedings of the Workshop on Performance Metrics for Intelligent Systems - PerMIS '12*, 15. College Park, Maryland: ACM Press, 2012. <https://doi.org/10.1145/2393091.2393095>.
- [2] Chou, Jack C. K., and M. Kamel. "Finding the Position and Orientation of a Sensor on a Robot Manipulator Using Quaternions". *The International Journal of Robotics Research* 10, no. 3 (June 1991): 240-54. <https://doi.org/10.1177/027836499101000305>.
- [3] Jiao, Jianhao, Yang Yu, Qinghai Liao, Haoyang Ye, Rui Fan, and Ming Liu. 'Automatic Calibration of Multiple 3D LiDARs in Urban Environments'. In *2019 IEEE/RSJ International Conference on Intelligent Robots and Systems (IROS)*, 15-20. Macau, China: IEEE, 2019. <https://doi.org/10.1109/IROS40897.2019.8967797>.

Copyright 2021 The MathWorks, Inc.

## See Also

### Apps

**Lidar Camera Calibrator**

## Extract Forest Metrics and Individual Tree Attributes from Aerial Lidar Data

This example shows how to extract forest metrics and individual tree attributes from aerial lidar data.

Forest study and applications increasingly make use of lidar data acquired from airborne laser scanning systems. Point cloud data from high density lidar enables measurement of not only forest metrics, but also attributes of individual trees.

This example uses point cloud data from a LAZ file captured by an airborne lidar system as input. In this example you first extract forest metrics by classifying point cloud data into ground and vegetation points, and then extract individual tree attributes by segmenting vegetation points into individual trees. This figure provides an overview of the process.

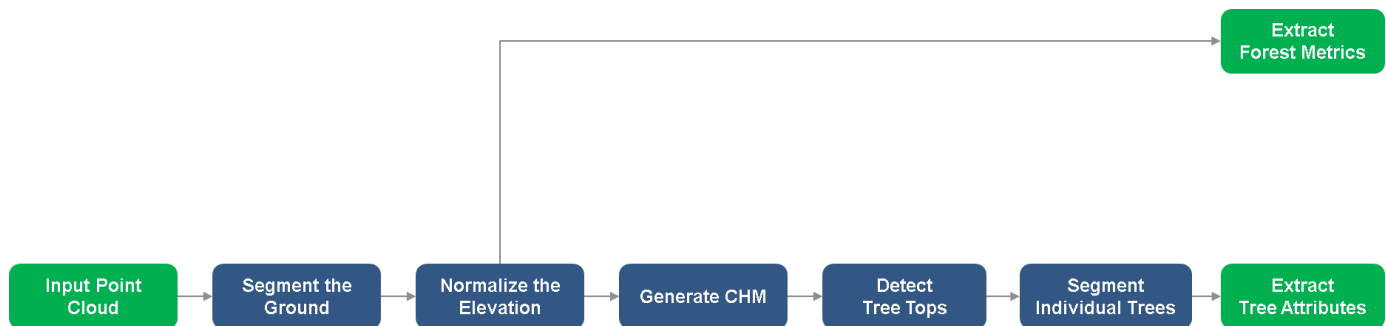

### Load and Visualize Data

Unzip `forestData.zip` to a temporary directory and load the point cloud data from the LAZ file, `forestData.laz`, into the MATLAB® workspace. The data is obtained from the Open Topography Dataset [1 on page 1-0 ]. The point cloud primarily contains ground and vegetation points. Load the point cloud data into the workspace using the `readPointCloud` function of the `lasFileReader` object. Visualize the point cloud using the `pcshow` function.

```

dataFolder = fullfile(tempdir,"forestData",filesep);
dataFile = dataFolder + "forestData.laz";
% Check whether the folder and data file already exist or not
folderExists = exist(dataFolder,'dir');
fileExists = exist(dataFile,'file');
% Create a new folder if it doesn't exist
if ~folderExists
    mkdir(dataFolder);
end
% Extract aerial data file if it doesn't exist
if ~fileExists
    unzip('forestData.zip',dataFolder);
end
% Read LAZ data from file
lasReader = lasFileReader(dataFile);
% Read point cloud along with corresponding scan angle information
[ptCloud,pointAttributes] = readPointCloud(lasReader,"Attributes","ScanAngle");
% Visualize the input point cloud
figure
pcshow(ptCloud.Location)
title("Input Point Cloud")
  
```



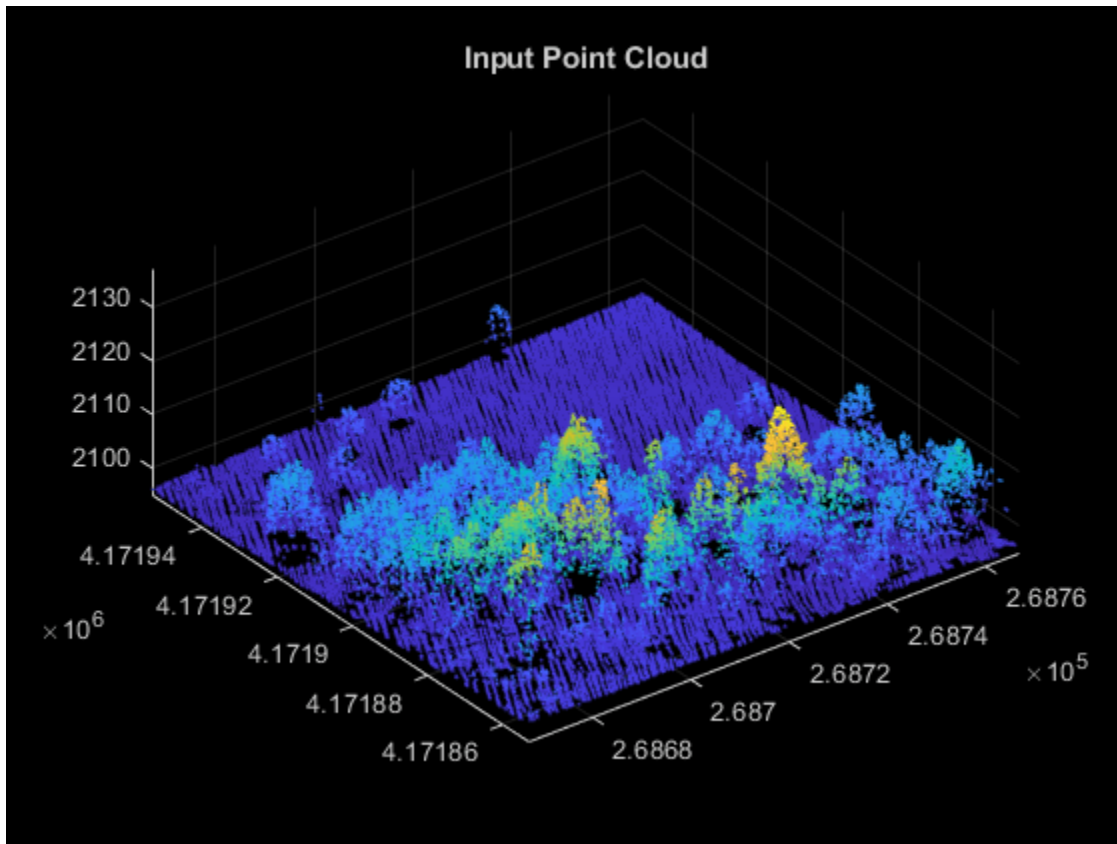

### Segment Ground

Ground segmentation is a preprocessing step to isolate the vegetation data for extracting forest metrics. Segment the data loaded from the LAZ file into ground and nonground points using the `segmentGroundSMRF` function.

```
% Segment Ground and extract non-ground and ground points
groundPtsIdx = segmentGroundSMRF(ptCloud);
nonGroundPtCloud = select(ptCloud,~groundPtsIdx);
groundPtCloud = select(ptCloud,groundPtsIdx);
% Visualize non-ground and ground points in magenta and green, respectively
figure
pcshowpair(nonGroundPtCloud,groundPtCloud)
title("Segmented Non-Ground and Ground Points")
```

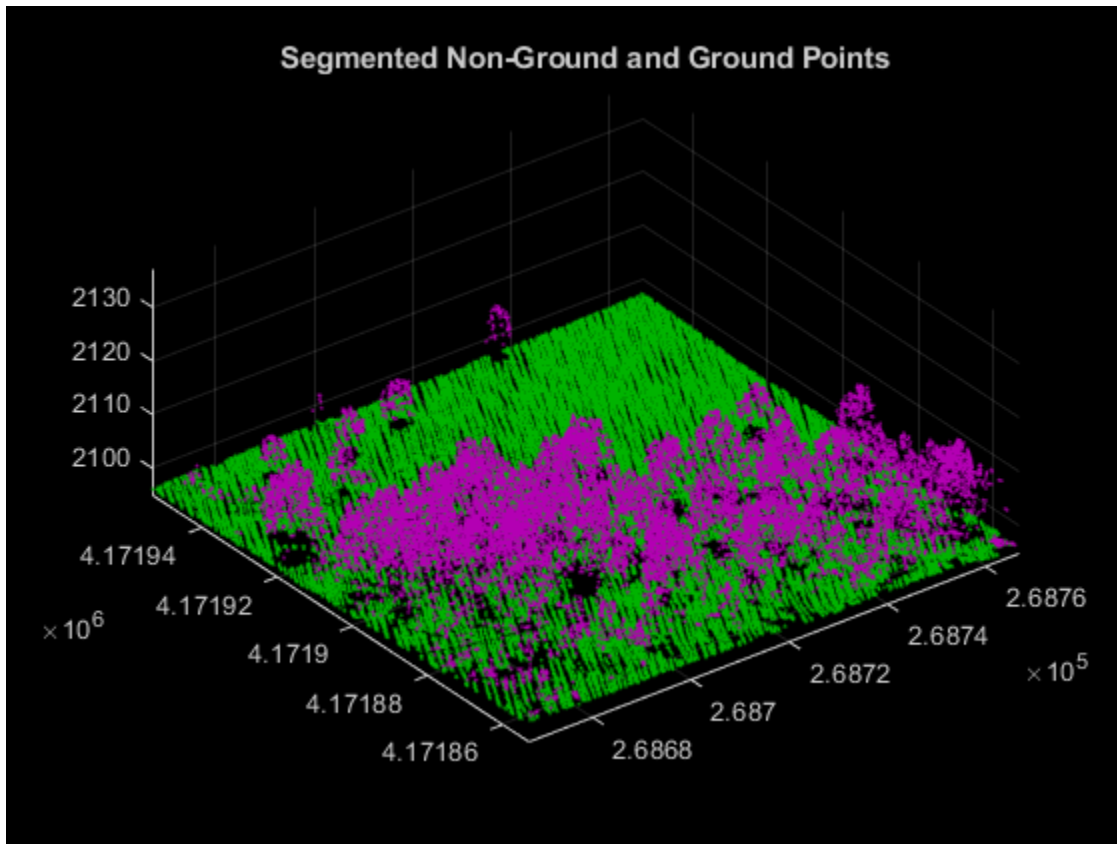

### Normalize the Elevation

Use elevation normalization to eliminate the effect of the terrain on your vegetation data. Use points with normalized elevation as input for computing forest metrics and tree attributes. These are the steps for elevation normalization.

- 1 Eliminate duplicate points along the x- and y-axes, if any, by using the `groupsummary` function.
- 2 Create an interpolant using the `scatteredInterpolant` object, to estimate ground at each point in the point cloud data.
- 3 Normalize the elevation of each point by subtracting the interpolated ground elevation from the original elevation.

```
groundPoints = groundPtCloud.Location;
% Eliminate duplicate points along x- and y-axes
[uniqueZ,uniqueXY] = groupsummary(groundPoints(:,3),groundPoints(:,1:2),@mean);
uniqueXY = [uniqueXY{:}];
% Create interpolant and use it to estimate ground elevation at each point
F = scatteredInterpolant(double(uniqueXY),double(uniqueZ),"natural");
estElevation = F(double(ptCloud.Location(:,1)),double(ptCloud.Location(:,2)));
% Normalize elevation by ground
normalizedPoints = ptCloud.Location;
normalizedPoints(:,3) = normalizedPoints(:,3) - estElevation;
% Visualize normalized points
figure
pcshow(normalizedPoints)
title("Point Cloud with Normalized Elevation")
```

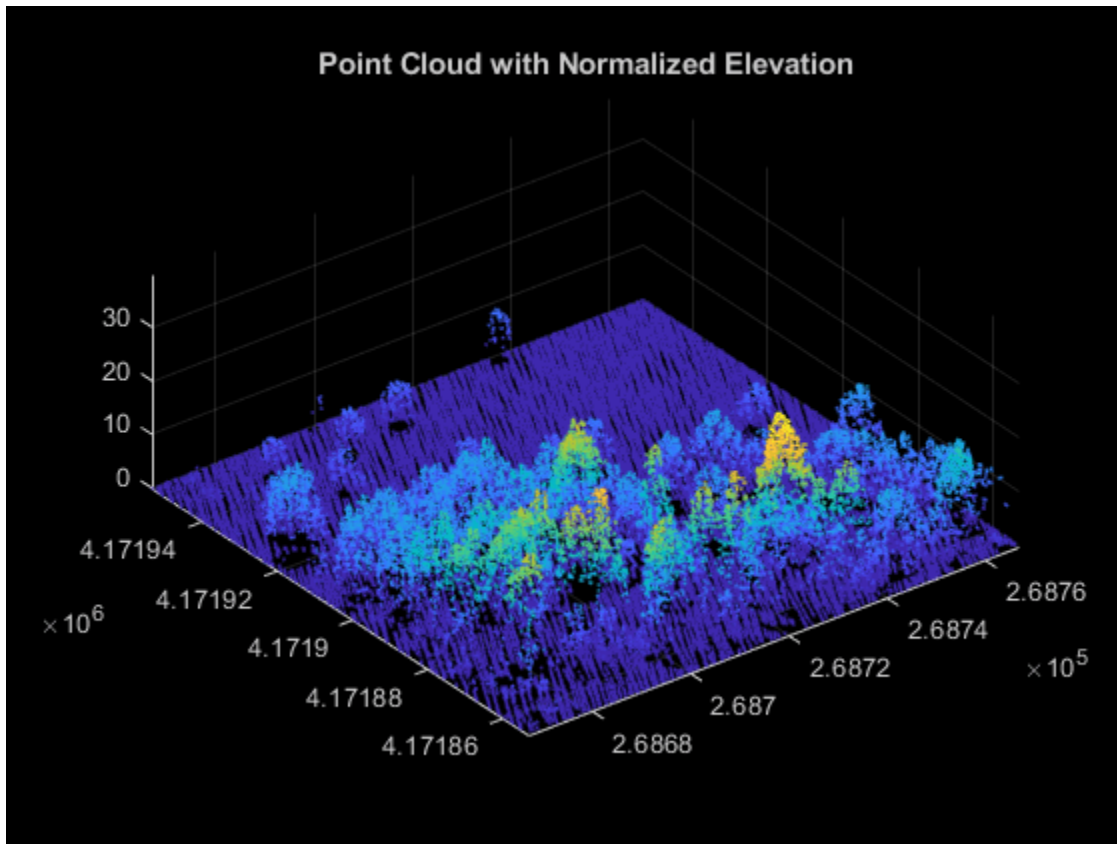

### Extract Forest Metrics

Extract forest metrics from the normalized points using the `helperExtractForestMetrics` helper function, attached to this example as a supporting file. The helper function first divides the point cloud into grids based on the provided `gridSize`, and then calculates the forest metrics. The helper function assumes that all points with a normalized height lower than `cutOffHeight` are ground and the remaining points are vegetation. Compute these forest metrics.

- Canopy Cover (CC) — *Canopy cover* [2 on page 1-0 ] is the proportion of the forest covered by the vertical projection of the tree crowns. Calculate it as the ratio of vegetation returns relative to the total number of returns.
- Gap fraction (GF) — *Gap fraction* [3 on page 1-0 ] is the probability of a ray of light passing through the canopy without encountering foliage or other plant elements. Calculate it as the ratio of ground returns relative to the total number of returns.
- Leaf area index (LAI) — *Leaf area index* [3 on page 1-0 ] is the amount of one-sided leaf area per unit of ground area. The LAI value is calculated using the equation  $LAI = -\frac{\cos(\text{ang}) \cdot \ln(\text{GF})}{k}$ , where `ang` is the average scan angle, `GF` is the gap fraction, and `k` is the extinction coefficient, which is closely related to the leaf-angle distribution.

```
% Set grid size to 10 meters per pixel and cutOffHeight to 2 meters
gridSize = 10;
cutOffHeight = 2;
leafAngDistribution = 0.5;
% Extract forest metrics
[canopyCover,gapFraction,leafAreaIndex] = helperExtractForestMetrics(normalizedPoints, ...
```

```

        pointAttributes.ScanAngle,gridSize,cutOffHeight,leafAngDistribution);
% Visualize forest metrics
hForestMetrics = figure;
axCC = subplot(2,2,1,Parent=hForestMetrics);
axCC.Position = [0.05 0.51 0.4 0.4];
imagesc(canopyCover,Parent=axCC)
title(axCC,"Canopy Cover")
axis off
colormap(gray)
axGF = subplot(2,2,2,Parent=hForestMetrics);
axGF.Position = [0.55 0.51 0.4 0.4];
imagesc(gapFraction,'Parent',axGF)
title(axGF,"Gap Fraction")
axis off
colormap(gray)
axLAI = subplot(2,2,[3 4],Parent=hForestMetrics);
axLAI.Position = [0.3 0.02 0.4 0.4];
imagesc(leafAreaIndex,Parent=axLAI)
title(axLAI,"Leaf Area Index")
axis off
colormap(gray)

```

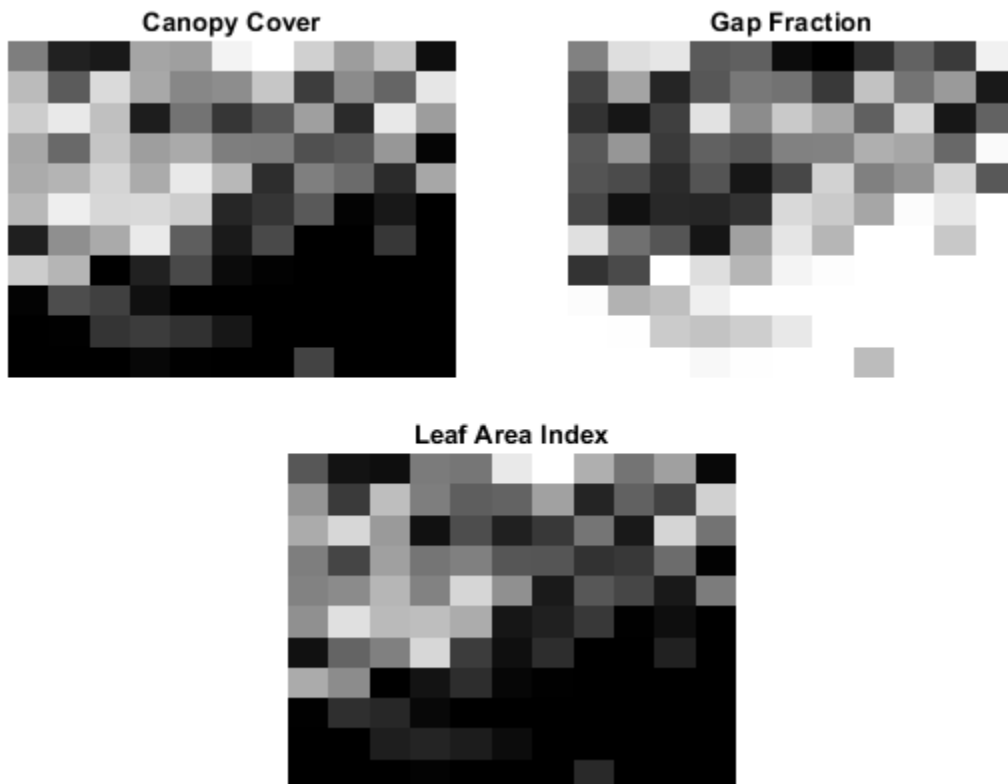

### Generate Canopy Height Model (CHM)

*Canopy height models* (CHMs) are raster representations of the height of trees, buildings, and other structures above the ground topography. Use a CHM as an input for tree detection and segmentation. Generate the CHM from your normalized elevation values using the `pc2dem` function.

```

% Set grid size to 0.5 meters per pixel
gridRes = 0.5;
% Generate CHM
canopyModel = pc2dem(pointCloud(normalizedPoints),gridRes,CornerFillMethod="max");
% Clip invalid and negative CHM values to zero
canopyModel(isnan(canopyModel) | canopyModel<0) = 0;
% Perform gaussian smoothing to remove noise effects
H = fspecial("gaussian",[5 5],1);
canopyModel = imfilter(canopyModel,H,'replicate','same');
% Visualize CHM
figure
imagesc(canopyModel)
title('Canopy Height Model')
axis off
colormap(gray)

```

Canopy Height Model

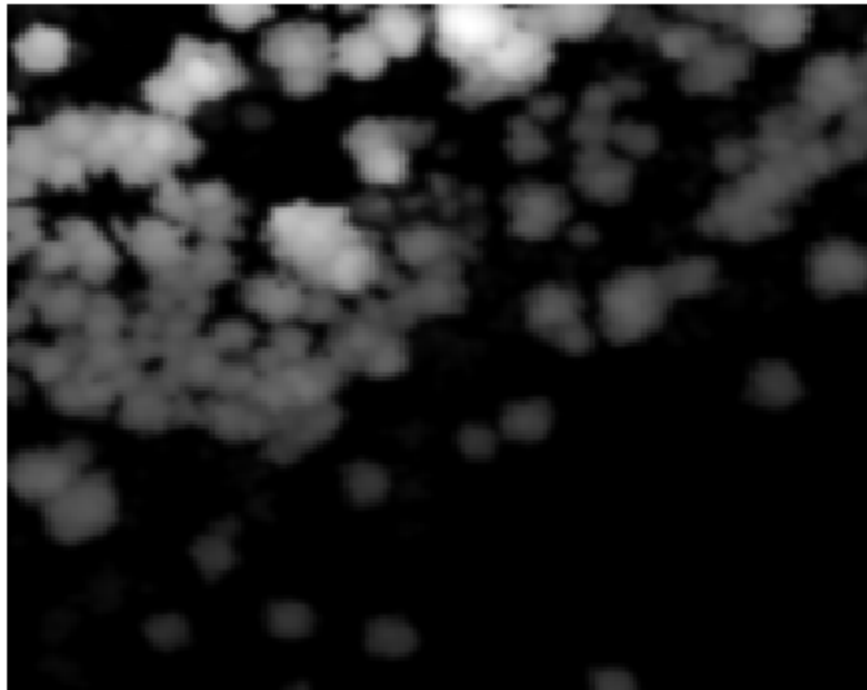

### Detect Tree Tops

Detect tree tops using the `helperDetectTreeTops` helper function, attached to this example as a supporting file. The helper function detects tree tops by finding the local maxima within variable window sizes [4 on page 1-0 ] in a CHM. For tree top detection, the helper function considers only points with a normalized height greater than `minTreeHeight`.

```

% Set minTreeHeight to 5 m
minTreeHeight = 5;
% Detect tree tops
[treeTopRowId,treeTopColId] = helperDetectTreeTops(canopyModel,gridRes,minTreeHeight);

```

```

% Visualize treetops
figure
imagesc(canopyModel)
hold on
plot(treeTopColId,treeTopRowId,"rx",MarkerSize=3)
title("CHM with Detected Tree Tops")
axis off
colormap("gray")

```

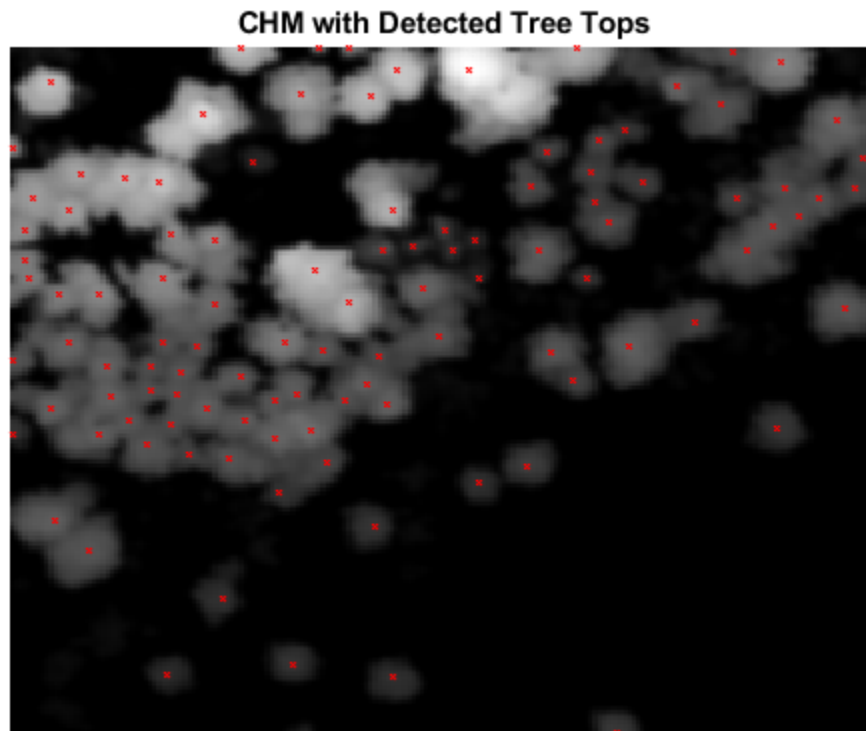

### Segment Individual Trees

Segment individual trees using the `helperSegmentTrees` helper function, attached to this example as a supporting file. The helper function utilizes marker-controlled watershed segmentation [5 on page 1-0 ] to segment individual trees. First, the function creates a binary marker image with tree top locations indicated by a value of 1 . Then, function filters the CHM complement by minima imposition to remove minima that are not tree tops. The function then performs watershed segmentation on the filtered CHM complement to segment individual trees. After segmentation, visualize the individual tree segments.

```

% Segment individual trees
label2D = helperSegmentTrees(canopyModel,treeTopRowId,treeTopColId,minTreeHeight);
% Identify row and column id of each point in label2D and transfer labels
% to each point
rowId = ceil((ptCloud.Location(:,2) - ptCloud.YLimits(1))/gridRes) + 1;
colId = ceil((ptCloud.Location(:,1) - ptCloud.XLimits(1))/gridRes) + 1;
ind = sub2ind(size(label2D),rowId,colId);
label3D = label2D(ind);

```

```

% Extract valid labels and corresponding points
validSegIds = label3D ~= 0;
ptVeg = select(ptCloud,validSegIds);
veglabel3D = label3D(validSegIds);
% Assign color to each label
numColors = max(veglabel3D);
colorMap = randi([0 255],numColors,3)/255;
labelColors = label2rgb(veglabel3D,colorMap,OutputFormat="triplets");
% Visualize tree segments
figure
pcshow(ptVeg.Location,labelColors)
title("Individual Tree Segments")
view(2)

```

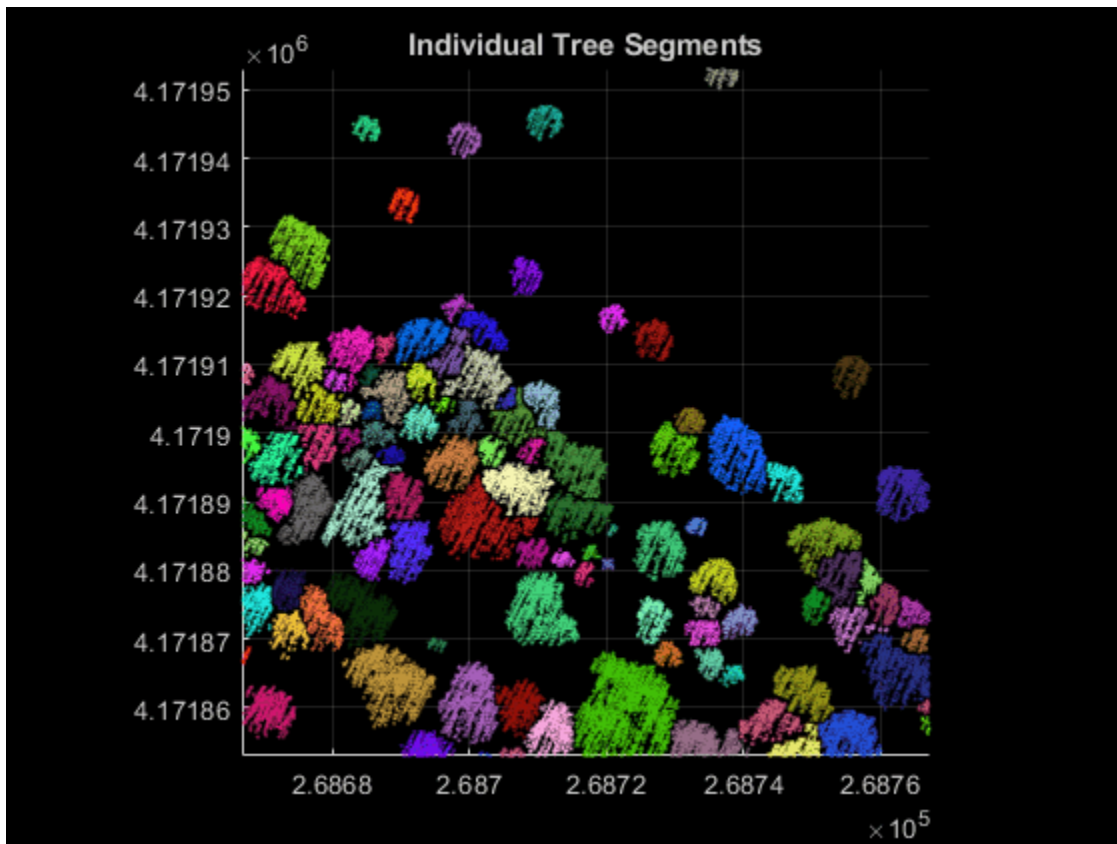

### Extract Tree Attributes

Extract individual tree attributes using the `helperExtractTreeMetrics` helper function, attached to this example as a supporting file. First, the function identifies points belonging to individual trees from labels. Then, the function extracts tree attributes such as tree apex location along the x- and y-axes, approximate tree height, tree crown diameter, and area. The helper function returns the attributes as a table, where each row represents the attributes of an individual tree.

```

% Extract tree attributes
treeMetrics = helperExtractTreeMetrics(normalizedPoints,label3D);
% Display first 5 tree segments metrics
disp(head(treeMetrics,5));

```

TreeId	NumPoints	TreeApexLocX	TreeApexLocY	TreeHeight	CrownDiameter	CrownA
1	388	2.6867e+05	4.1719e+06	29.509	7.5325	44.5
2	22	2.6867e+05	4.1719e+06	21.464	0.99236	0.773
3	243	2.6867e+05	4.1719e+06	24.201	5.7424	25.8
4	101	2.6867e+05	4.1719e+06	21.927	3.4571	9.38
5	54	2.6867e+05	4.1719e+06	19.515	3.0407	7.26

**References**

[1] Thompson, S. *Illilouette Creek Basin Lidar Survey, Yosemite Valley, CA 2018*. National Center for Airborne Laser Mapping (NCALM). Distributed by OpenTopography. <https://doi.org/10.5069/G96M351N>. Accessed: 2021-05-14

[2] Ma, Qin, Yanjun Su, and Qinghua Guo. "Comparison of Canopy Cover Estimations From Airborne LiDAR, Aerial Imagery, and Satellite Imagery." *IEEE Journal of Selected Topics in Applied Earth Observations and Remote Sensing* 10, no. 9 (September 2017): 4225–36. <https://doi.org/10.1109/JSTARS.2017.2711482>.

[3] Richardson, Jeffrey J., L. Monika Moskal, and Soo-Hyung Kim. "Modeling Approaches to Estimate Effective Leaf Area Index from Aerial Discrete-Return LIDAR." *Agricultural and Forest Meteorology* 149, no. 6–7 (June 2009): 1152–60. <https://doi.org/10.1016/j.agrformet.2009.02.007>.

[4] Pitkänen, J., M. Maltamo, J. Hyyppä, and X. Yu. "Adaptive Methods for Individual Tree Detection on Airborne Laser Based Canopy Height Model." *International Archives of Photogrammetry, Remote Sensing and Spatial Information Sciences* 36, no. 8 (January 2004): 187–91.

[5] Chen, Qi, Dennis Baldocchi, Peng Gong, and Maggi Kelly. "Isolating Individual Trees in a Savanna Woodland Using Small Footprint Lidar Data." *Photogrammetric Engineering & Remote Sensing* 72, no. 8 (August 1, 2006): 923–32. <https://doi.org/10.14358/PERS.72.8.923>.



# Code Generation For Aerial Lidar Semantic Segmentation Using PointNet++ Deep Learning

This example shows how to generate CUDA® MEX code for a PointNet++ [1 on page 1-0 ] network for lidar semantic segmentation. This example uses a pretrained PointNet++ network that can segment unorganized lidar point clouds belonging to eight classes (buildings, cars, trucks, poles, power lines, fences, ground, and vegetation). For more information on PointNet++ network, see “Getting Started with PointNet++” on page 4-52.

## Third-Party Prerequisites

### Required

- CUDA enabled NVIDIA® GPU and compatible driver.

### Optional

For non-MEX builds such as static libraries, dynamic libraries, or executables, this example has the following additional requirements.

- NVIDIA toolkit.
- NVIDIA cuDNN library.
- Environment variables for the compilers and libraries. For more information, see “Third-Party Hardware” (GPU Coder) and “Setting Up the Prerequisite Products” (GPU Coder).

## Verify GPU Environment

To verify that the compilers and libraries for running this example are set up correctly, use the `coder.checkGpuInstall` (GPU Coder) function.

```
envCfg = coder.gpuEnvConfig('host');
envCfg.DeepLibTarget = 'cudnn';
envCfg.DeepCodegen = 1;
envCfg.Quiet = 1;
coder.checkGpuInstall(envCfg);
```

## Load PointNet++ Network

Use the `getPointnetplusNet` function, attached as a supporting file to this example, to load the pretrained PointNet++ network. For more information on how to train this network, see “Aerial Lidar Semantic Segmentation Using PointNet++ Deep Learning” on page 1-324 example.

```
net = getPointnetplusNet;
```

The pretrained network is a DAG network. To display an interactive visualization of the network architecture, use the `analyzeNetwork` (Deep Learning Toolbox) function.

The sampling and grouping layer, and the interpolation layer are implemented using the `functionLayer` (Deep Learning Toolbox), that does not support code generation. So, replace the function layers in the network with custom layers that support code generation using the `helperReplaceFunctionLayers` helper function and save the network as a MAT file with the name `pointnetplusCodegenNet.mat`.

```
net = helperReplaceFunctionLayers(net);
```

### **pointnetplusPredict Entry-Point Function**

The `pointnetplusPredict` entry-point function takes a point cloud data matrix as input and performs prediction on it by using the deep learning network saved in the `pointnetplusCodegenNet.mat` file. The function loads the network object from the `pointnetplusCodegenNet.mat` file into a persistent variable `mynet` and reuses the persistent variable in subsequent prediction calls.

```
type('pointnetplusPredict.m');

function out = pointnetplusPredict(in)
%#codegen

% A persistent object mynet is used to load the DAG network object. At
% the first call to this function, the persistent object is constructed and
% setup. When the function is called subsequent times, the same object is
% reused to call predict on inputs, thus avoiding reconstructing and
% reloading the network object.

% Copyright 2021 The MathWorks, Inc.

persistent mynet;

if isempty(mynet)
    mynet = coder.loadDeepLearningNetwork('pointnetplusCodegenNet.mat');
end

% pass in input
out = predict(mynet,in);
```

### **Generate CUDA MEX Code**

To generate CUDA® code for the `pointnetplusPredict` entry-point function, create a GPU code configuration object for a MEX target and set the target language to C++. Use the `coder.DeepLearningConfig` (GPU Coder) function to create a CuDNN deep learning configuration object and assign it to the `DeepLearningConfig` property of the GPU code configuration object. Run the `codegen` command with the size of point cloud data in the input layer of the network, which in this case is `[8192 1 3]`.

```
cfg = coder.gpuConfig('mex');
cfg.TargetLang = 'C++';
cfg.DeepLearningConfig = coder.DeepLearningConfig(TargetLibrary='cudnn');
codegen -config cfg pointnetplusPredict -args {randn(8192,1,3,'single')} -report
```

Code generation successful: [View report](#)

To generate CUDA® code for the TensorRT target, create and use a TensorRT deep learning configuration object instead of the CuDNN configuration object.

### **Segment Aerial Point Cloud Using Generated MEX Code**

The network in this example is trained on the DALES data set [2 on page 1-0]. Follow the instructions on the DALES website to download the data set to the folder specified by the `dataFolder` variable. Create a folder to store the test data.

```
dataFolder = fullfile(tempdir,'DALES');
testDataFolder = fullfile(dataFolder,'dales_las','test');
```

Each point cloud in the DALES dataset covers an area of 500-by-500 meters, which is much larger than the typical area covered by terrestrial lidar point clouds. For efficient memory processing, divide the point cloud into small, non-overlapping blocks by using a `blockedPointCloud` object.

Define the block dimensions using the `blockSize` parameter. As the size of each point cloud in the dataset varies, set the z-dimension of the block to `Inf` to avoid block creation along z-axis.

```
blockSize = [51 51 Inf];
```

First, create a `blockedPointCloud` object. Then, create a `blockedPointCloudDatastore` object on the test data using the `blockedPointCloud` object.

```
tbbc = blockedPointCloud(fullfile(testDataFolder, '5080_54470.las'), blockSize);
tbpcds = blockedPointCloudDatastore(tbbc);
```

Define the parameters used to train the network. For more details, see the “Aerial Lidar Semantic Segmentation Using PointNet++ Deep Learning” on page 1-324 example.

```
numNearestNeighbors = 20;
radius = 0.05;
numPoints = 8192;
maxLabel = 1;
classNames = [
    "ground"
    "vegetation"
    "cars"
    "trucks"
    "powerlines"
    "fences"
    "poles"
    "buildings"
];
numClasses = numel(classNames);
```

Initialize placeholders for the predicted and target labels.

```
labelsDensePred = [];
labelsDenseTarget = [];
```

Apply the same transformation used on training data to the test data, `tbpcds`, follow these steps.

- Extract the point cloud.
- Downsample the point cloud to a specified number, `numPoints`.
- Normalize the point clouds to the range [0 1].
- Convert the point cloud to make it compatible with the input layer of the network.

Perform inference on the test point cloud data to compute prediction labels. Predict the labels of the sparse point cloud using the `pointnetplusPredict_mex` function. Then interpolate the prediction labels of the sparse point cloud to obtain prediction labels of the dense point cloud and iterate this process on all the non-overlapping blocks.

```
while hasdata(tbpcds)
    % Read the block along with block information.
    [ptCloudDense, infoDense] = read(tbpcds);
```

```

% Extract the labels from the block information.
labelsDense = infoDense.PointAttributes.Classification;

% Select only labeled data.
ptCloudDense = select(ptCloudDense{1},labelsDense~=0);
labelsDense = labelsDense(labelsDense~=0);

% Use the helperDownsamplePoints function, attached to this example as a
% supporting file, to extract a downsampled point cloud from the
% dense point cloud.
ptCloudSparse = helperDownsamplePoints(ptCloudDense, ...
    labelsDense,numPoints);

% Make the spatial extent of the dense point cloud equal to the sparse
% point cloud.
limits = [ptCloudDense.XLimits;ptCloudDense.YLimits;ptCloudDense.ZLimits];
ptCloudSparseLocation = ptCloudSparse.Location;
ptCloudSparseLocation(1:2,:) = limits(:,1:2)';
ptCloudSparse = pointCloud(ptCloudSparseLocation,Color=ptCloudSparse.Color, ...
    Intensity=ptCloudSparse.Intensity, Normal=ptCloudSparse.Normal);

% Use the helperNormalizePointCloud function, attached to this example as
% a supporting file, to normalize the point cloud between 0 and 1.
ptCloudSparseNormalized = helperNormalizePointCloud(ptCloudSparse);
ptCloudDenseNormalized = helperNormalizePointCloud(ptCloudDense);

% Use the helperTransformToTestData function, defined at the end of this
% example, to convert the point cloud to a cell array and to permute the
% dimensions of the point cloud to make it compatible with the input layer
% of the network.
ptCloudSparseForPrediction = helperTransformToTestData(ptCloudSparseNormalized);

% Get the output predictions.
scoresPred = pointnetplusPredict_mex(single(ptCloudSparseForPrediction{1,1}));
[~,labelsSparsePred] = max(scoresPred,[],3);
labelsSparsePred = uint8(labelsSparsePred);

% Use the helperInterpolate function, attached to this example as a
% supporting file, to calculate labels for the dense point cloud,
% using the sparse point cloud and labels predicted on the sparse point cloud.
interpolatedLabels = helperInterpolate(ptCloudDenseNormalized, ...
    ptCloudSparseNormalized,labelsSparsePred,numNearestNeighbors, ...
    radius,maxLabel,numClasses);

% Concatenate the predicted and target labels from the blocks.
labelsDensePred = vertcat(labelsDensePred,interpolatedLabels);
labelsDenseTarget = vertcat(labelsDenseTarget,labelsDense);
end

```

Starting parallel pool (parpool) using the 'local' profile ...  
Connected to the parallel pool (number of workers: 12).

For better visualisation, display a single block inferred from the point cloud data.

```

figure;
ax = pcsshow(ptCloudDense.Location,interpolatedLabels);

```

Warning: MATLAB has disabled some advanced graphics rendering features by switching to software (

```
axis off;
helperLabelColorbar(ax,classNames);
title("Point Cloud Overlaid with Detected Semantic Labels");
```

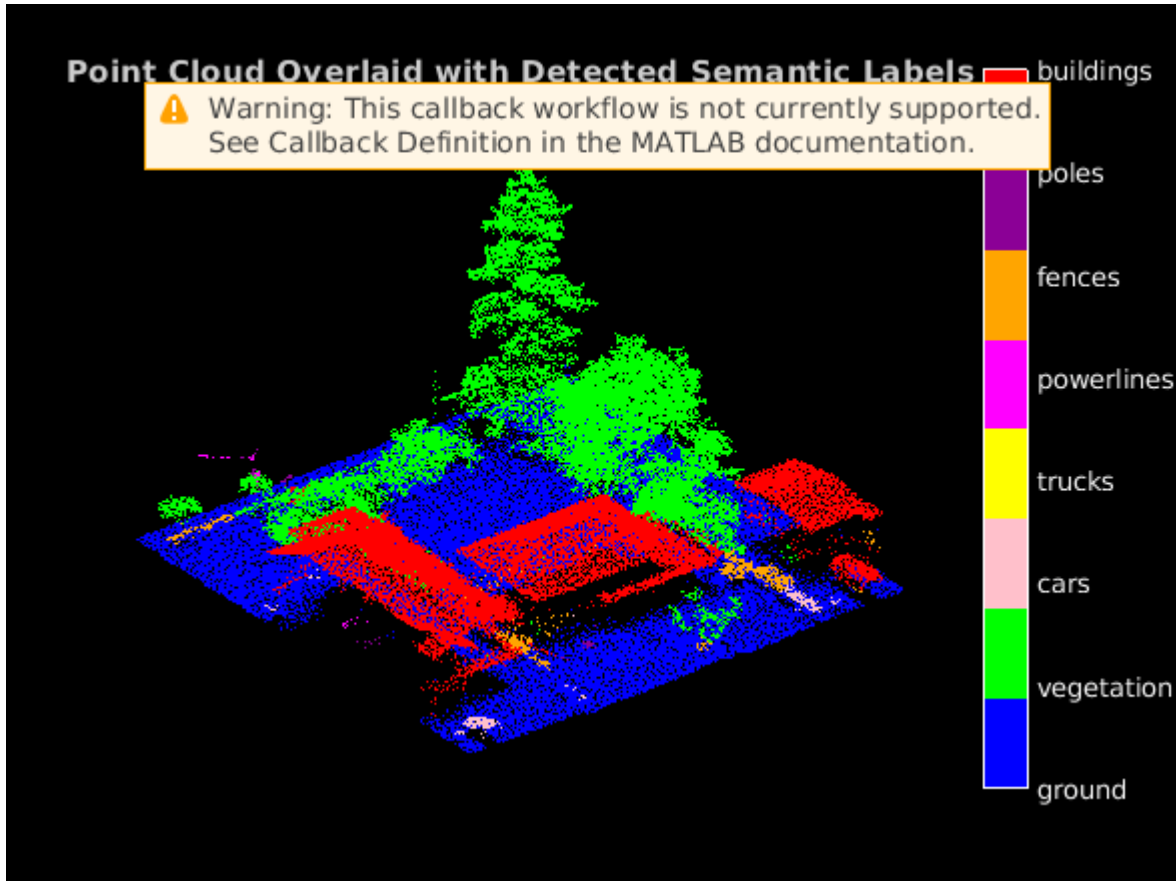

### Supporting Functions

The `helperLabelColorbar` function adds a colorbar to the current axis. The colorbar is formatted to display the class names with the color.

```
function helperLabelColorbar(ax,classNames)
% Colormap for the original classes.
cmap = [[0,0,255];
        [0,255,0];
        [255,192,203];
        [255,255,0];
        [255,0,255];
        [255,165,0];
        [139,0,150];
        [255,0,0]];
cmap = cmap./255;
cmap = cmap(1:numel(classNames),:);
colormap(ax,cmap);

% Add colorbar to current figure.
c = colorbar(ax);
c.Color = 'w';
```

```
% Center tick labels and use class names for tick marks.
numClasses = size(classNames, 1);
c.Ticks = 1:1:numClasses;
c.TickLabels = classNames;

% Remove tick mark.
c.TickLength = 0;
end
```

The `helperTransformToTestData` function converts the point cloud into a cell array and permutes the dimensions of the point cloud to make it compatible with the input layer of the network.

```
function data = helperTransformToTestData(data)
if ~iscell(data)
    data = {data};
end
numObservations = size(data,1);
for i = 1:numObservations
    tmp = data{i,1}.Location;
    data{i,1} = permute(tmp,[1 3 2]);
end
end
```

## References

- [1] Qi, Charles R., Li Yi, Hao Su, and Leonidas J. Guibas. "PointNet++: Deep Hierarchical Feature Learning on Point Sets in a Metric Space." *ArXiv:1706.02413 [Cs]*, June 7, 2017. <https://arxiv.org/abs/1706.02413>.
- [2] Varney, Nina, Vijayan K. Asari, and Quinn Graehling. "DALES: A Large-Scale Aerial LiDAR Data Set for Semantic Segmentation." *ArXiv:2004.11985 [Cs, Stat]*, April 14, 2020. <https://arxiv.org/abs/2004.11985>.

## Build Map and Localize Using Segment Matching

This example shows how to build a map with lidar data and localize the position of a vehicle on the map using SegMatch [1] on page 1-0 , a place recognition algorithm based on segment matching.

Autonomous driving systems use localization to determine the position of the vehicle within a mapped environment. Autonomous navigation requires accurate localization, which relies on an accurate map. Building an accurate map of large scale environments is difficult because the map accumulates drift over time, and detecting loop closures to correct for accumulated drift is challenging due to dynamic obstacles. The SegMatch algorithm is robust to dynamic obstacles and reliable in large scale environments. The algorithm is a segment-based approach that takes advantage of descriptive shapes and recognizes places by matching segments.

### Overview

Like the “Build a Map from Lidar Data Using SLAM” example, this example uses 3-D lidar data to build a map and corrects for the accumulated drift using graph SLAM. However, this example does not require global pose estimates from other sensors, such as an inertial measurement unit (IMU). After building the map, this example uses it to localize the vehicle in a known environment.

In this example, you learn how to:

- Use SegMatch to find the relative transformation between two point clouds that correspond to the same place
- Build a map using SegMatch for loop closure detection
- Localize on a prebuilt map using SegMatch

### Download Data

The data used in this example is part of the Velodyne SLAM Dataset. It includes approximately 6 minutes of data recorded with a Velodyne® HDL64E-S2 scanner. Download the data to a temporary directory. This can take a few minutes.

```
baseDownloadURL = 'https://www.mrt.kit.edu/z/publ/download/velodyneslam/data/scenario1.zip';
dataFolder = fullfile(tempdir,'kit_velodyneslam_data_scenario1',filesep);
options = weboptions('Timeout',Inf);

zipFileName = dataFolder+"scenario1.zip";

% Get the full file path to the PNG files in the scenario1 folder.
pointCloudFilePattern = fullfile(dataFolder,'scenario1','scan*.png');
numExpectedFiles = 2513;

folderExists = exist(dataFolder,'dir');
if ~folderExists
    % Create a folder in a temporary directory to save the downloaded zip file.
    mkdir(dataFolder)

    disp('Downloading scenario1.zip (153 MB) ...')
    websave(zipFileName,baseDownloadURL,options);

    % Unzip downloaded file.
    unzip(zipFileName,dataFolder)

elseif folderExists && numel(dir(pointCloudFilePattern)) < numExpectedFiles
```

```
% Redownload the data if it got reduced in the temporary directory.
disp('Downloading scenario1.zip (153 MB) ...')
websave(zipFileName,baseDownloadURL,options);

% Unzip downloaded file.
unzip(zipFileName,dataFolder)
end
```

### Load and Select Data

The downloaded dataset stores point cloud data in PNG files. Create a file datastore using the `helperReadVelodyneSLAMData` on page 1-0 function to load point cloud data from the PNG files and convert distance values to 3-D coordinates. The helper function is a custom read function, which is designed for the Velodyne SLAM Dataset. Select a subset of the data and split the data to use for map building and for localization.

```
% Create a file datastore to read files in the right order.
fileDS = fileDatastore(pointCloudFilePattern,'ReadFcn', ...
    @helperReadVelodyneSLAMData);

% Read the point clouds.
ptCloudArr = readall(fileDS);

% Select a subset of point cloud scans, and split the data to use for
% map building and for localization.
ptCloudMap = vertcat(ptCloudArr{1:5:1550});
ptCloudLoc = vertcat(ptCloudArr{2:5:1550});

% Visualize the first point cloud.
figure
pcshow(ptCloudMap(1))
title('Point Cloud Data')
```



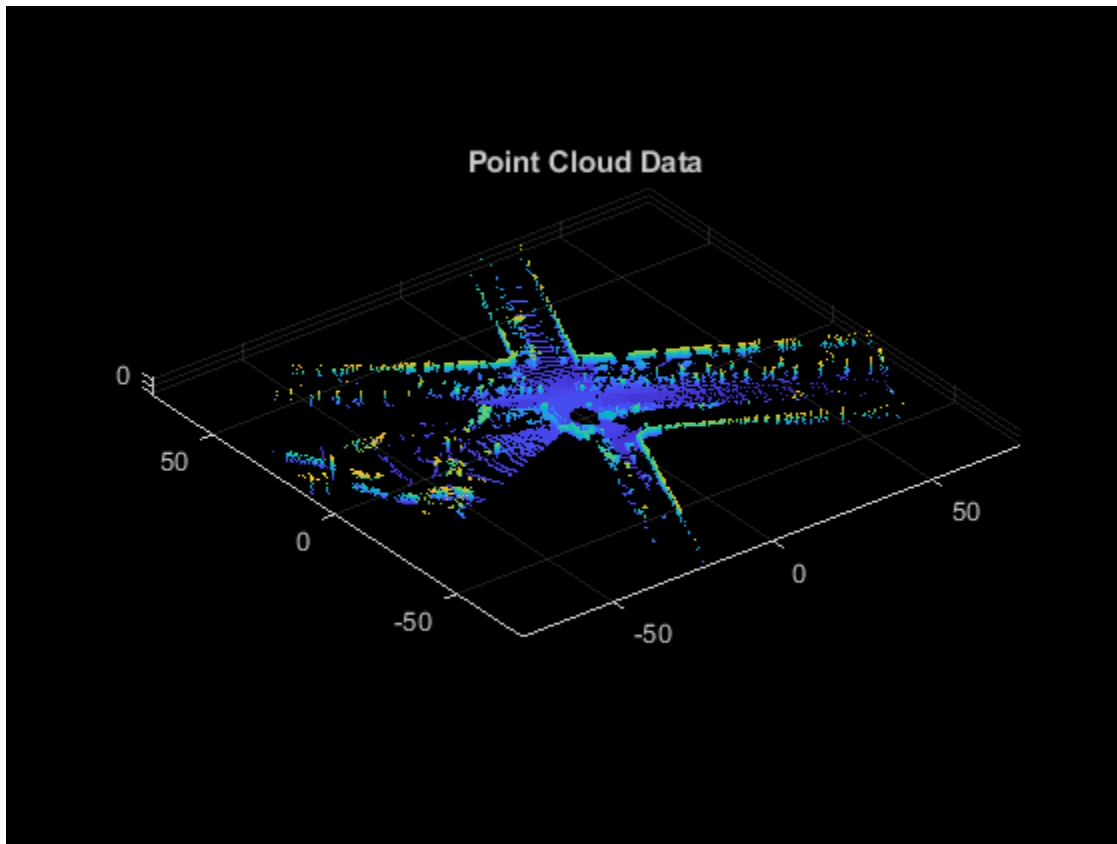

### SegMatch Overview

The SegMatch algorithm consists of four different components: point cloud segmentation, feature extraction, segment matching, and geometric verification. For best results, preprocess the point cloud before performing these four steps.

### Preprocess Point Cloud

To select the most relevant point cloud data, perform the following preprocessing steps:

- 1 Select a cylindrical neighborhood centered around the vehicle to extract a local point cloud of interest. First, specify a cylindrical neighborhood based on the distance of the points from the origin in the  $x$  and  $y$  directions. Then, select the area of interest using `select`.
- 2 Remove the ground in preparation to segment the point cloud into distinct objects. Use `segmentGroundSMRF` to segment the ground.

```
% Select a point cloud from the map for preprocessing.
```

```
ptCloud = ptCloudMap(25);
```

```
% Set the cylinder radius and ego radius.
```

```
cylinderRadius = 40;
```

```
egoRadius = 1;
```

```
% Compute the distance between each point and the origin.
```

```
dists = hypot(ptCloud.Location(:, :, 1), ptCloud.Location(:, :, 2));
```

```
% Select the points inside the cylinder radius and outside the ego radius.
```

```
cylinderIdx = dists <= cylinderRadius & dists >= egoRadius;
cylinderPtCloud = select(ptCloud,cylinderIdx,'OutputSize','full');

% Remove the ground.
[~,ptCloudNoGround] = segmentGroundSMRF(cylinderPtCloud,'ElevationThreshold',0.05);

% Visualize the point cloud before and after preprocessing.
figure
pcshowpair(ptCloud,ptCloudNoGround)
title('Point Cloud Before and After Preprocessing')
```

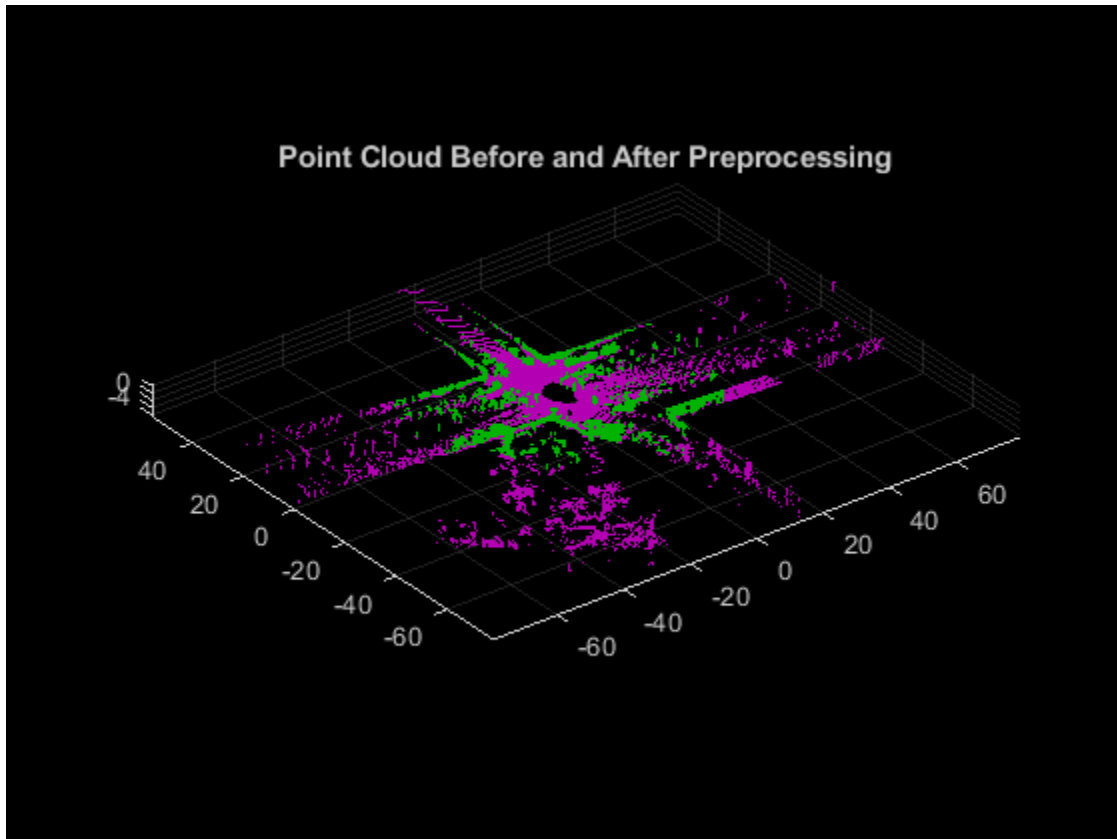

### Segmentation and Feature Extraction

Next, segment the point cloud and extract features from each segment.

Segment the point cloud by using the `segmentLidarData` function and visualize the segments. For this example, each segment must have a minimum of 150 points. This produces segment clusters that represent distinct objects and have enough points to characterize the area in the map.

Different datasets require different parameters for segmentation. Requiring fewer points for segments can lead to false positive loop closures, and limiting the segments to larger clusters can eliminate segments that are important for place recognition. You must also tune the distance and angle thresholds to ensure that each segment corresponds to one object. A small distance threshold can result in many segments that correspond to the same object, and a large distance threshold and small angle threshold can result in segments that combine many objects.

```

minNumPoints = 150;
distThreshold = 1;
angleThreshold = 180;
[labels,numClusters] = segmentLidarData(ptCloudNoGround,distThreshold, ...
    angleThreshold,'NumClusterPoints',minNumPoints);

% Remove points that contain a label value of 0 for visualization.
idxValidPoints = find(labels);
labelColorIndex = labels(idxValidPoints);
segmentedPtCloud = select(ptCloudNoGround,idxValidPoints);

figure
pcshow(segmentedPtCloud.Location,labelColorIndex)
title('Point Cloud Segments')

```

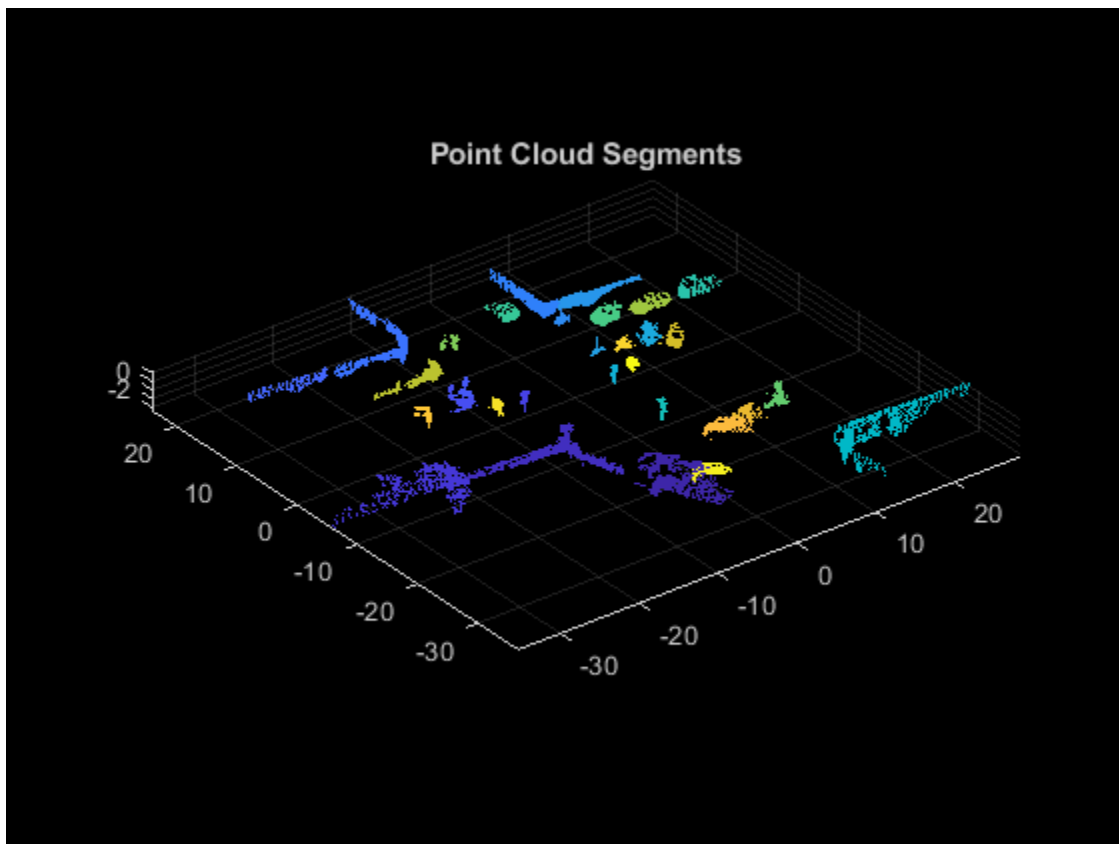

Extract features from each segment by using the `extractEigenFeatures` function. Eigenvalue-based features are geometric features. Each feature vector includes linearity, planarity, scattering, omnivariance, anisotropy, eigenentropy, and change in curvature.

```

[features,segments] = extractEigenFeatures(ptCloud,labels);
disp(features)

```

```

31x1 eigenFeature array with properties:

```

```

    Feature
    Centroid

```

```

disp(segments)

```

31x1 pointCloud array with properties:

```
Location
Count
XLimits
YLimits
ZLimits
Color
Normal
Intensity
```

### Segment Matching and Geometric Verification

Find the matching segments and the transformation between the segments for two point cloud scans that correspond to a loop closure.

Preprocess and extract segment features from the two point clouds. The `helperPreProcessPointCloud` on page 1-0 function includes the preprocessing steps in the Preprocess Point Cloud on page 1-0 section, to simplify preprocessing the point cloud throughout the workflow.

```
ptCloud1 = ptCloudMap(27);
ptCloud2 = ptCloudMap(309);

ptCloud1 = helperPreProcessPointCloud(ptCloud1,egoRadius,cylinderRadius);
ptCloud2 = helperPreProcessPointCloud(ptCloud2,egoRadius,cylinderRadius);

labels1 = segmentLidarData(ptCloud1,distThreshold, ...
    angleThreshold,'NumClusterPoints',minNumPoints);
labels2 = segmentLidarData(ptCloud2,distThreshold, ...
    angleThreshold,'NumClusterPoints',minNumPoints);

[features1,segments1] = extractEigenFeatures(ptCloud1,labels1);
[features2,segments2] = extractEigenFeatures(ptCloud2,labels2);
```

Find the possible segment matches based on the normalized euclidean distance between the feature vectors by using the `pcmatchfeatures` function.

```
featureMatrix1 = vertcat(features1.Feature);
featureMatrix2 = vertcat(features2.Feature);
indexPairs = pcmatchfeatures(featureMatrix1,featureMatrix2);
```

Perform geometric verification by identifying inliers and finding the 3-D rigid transformation between segment matches using the `estimateGeometricTransform3D` function. Based on the number of inliers, the point clouds can be classified as a loop closure.

```
centroids1 = vertcat(features1(indexPairs(:,1)).Centroid);
centroids2 = vertcat(features2(indexPairs(:,2)).Centroid);
[tform,inlierPairs] = estimateGeometricTransform3D(centroids1,centroids2,'rigid');
```

Visualize the segment matches by using the `pcshowMatchedFeatures` function.

```
inlierIdx1 = indexPairs(inlierPairs,1);
inlierIdx2 = indexPairs(inlierPairs,2);
figure
pcshowMatchedFeatures(segments1(inlierIdx1),segments2(inlierIdx2), ...
    features1(inlierIdx1),features2(inlierIdx2))
title('Segment Matches')
```

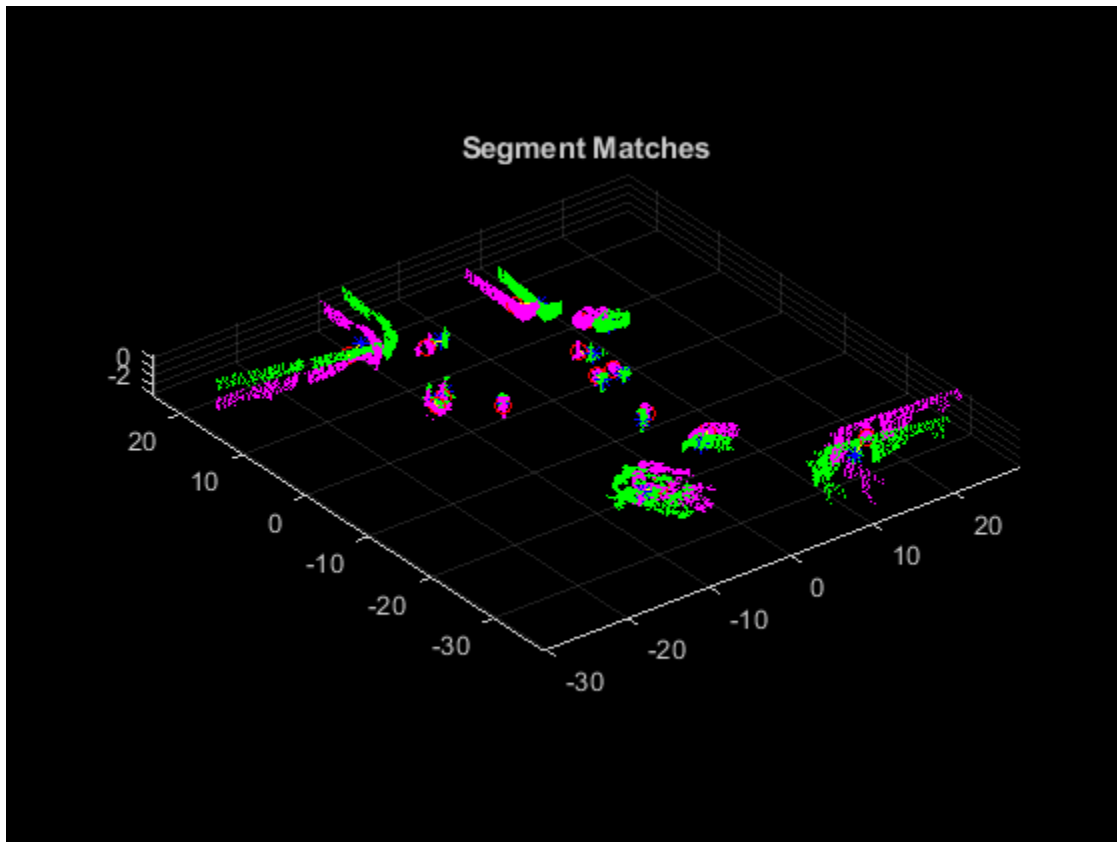

Align the segments with the transformation from the geometric verification step using `pccat` and `pctransform`.

```
ptCloudSegments1 = pccat(segments1);  
ptCloudSegments2 = pccat(segments2);  
tformedPtCloudSegments1 = pctransform(ptCloudSegments1,tform);
```

Visualize the aligned segments using `pcshowpair`.

```
figure  
pcshowpair(tformedPtCloudSegments1,ptCloudSegments2)  
title('Aligned Segments')
```

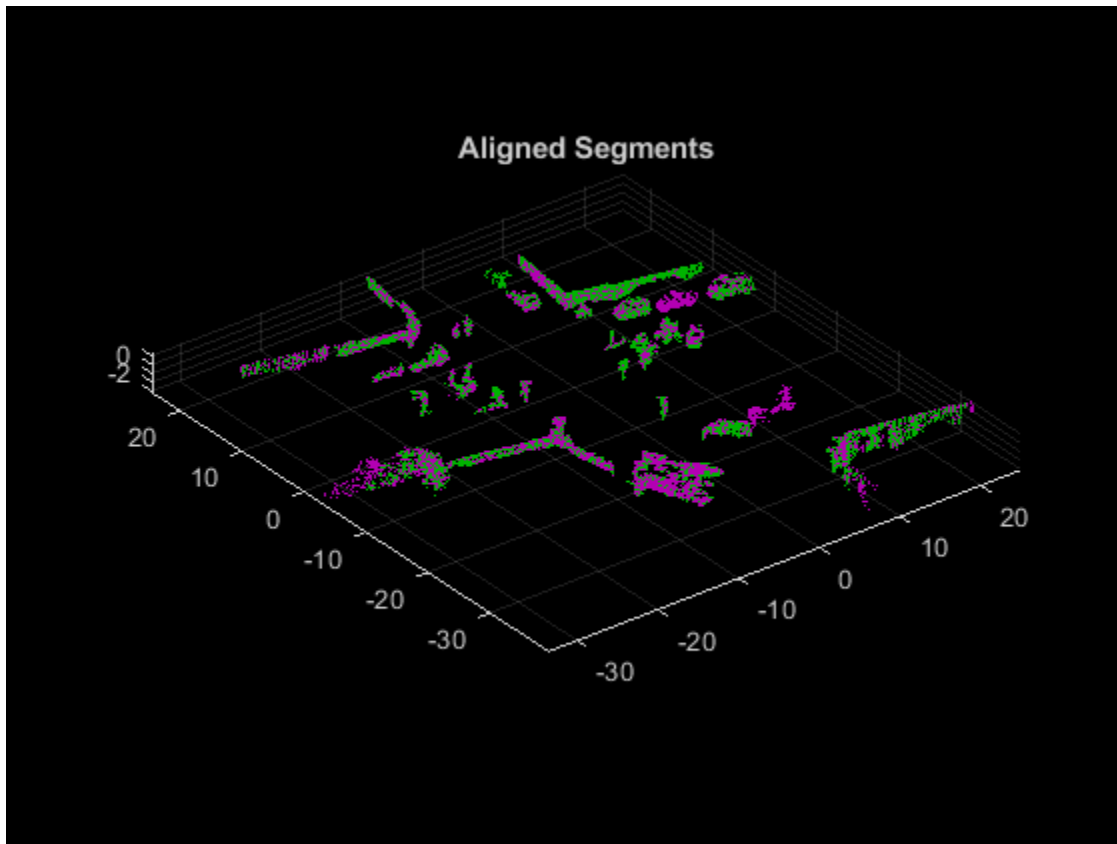

### Build Map

The map building procedure consists of the following steps:

- 1 Preprocess the point cloud
- 2 Register the point cloud
- 3 Segment the point cloud and extract features
- 4 Detect loop closures

### Preprocess Point Cloud

Preprocess the previous and current point cloud using `helperPreProcessPointCloud` on page 1-0 . Downsample the point clouds using `pcdownsample` to improve registration speed and accuracy. To tune the downsample percentage input, find the lowest value that maintains the desired registration accuracy when the vehicle turns.

```
currentViewId = 2;  
  
prevPtCloud = helperPreProcessPointCloud(ptCloudMap(currentViewId-1), ...  
    egoRadius,cylinderRadius);  
ptCloud = helperPreProcessPointCloud(ptCloudMap(currentViewId), ...  
    egoRadius,cylinderRadius);  
  
downsamplePercent = 0.5;
```

```
prevPtCloudFiltered = pcdsample(prevPtCloud, 'random', downsamplePercent);
ptCloudFiltered = pcdsample(ptCloud, 'random', downsamplePercent);
```

### Register Point Cloud

Register the current point cloud with the previous point cloud to find the relative transformation.

```
gridStep = 3;
relPose = pcregisterndt(ptCloudFiltered, prevPtCloudFiltered, gridStep);
```

Use a `pcviewset` object to track absolute poses and connections between registered point clouds. Create an empty `pcviewset`.

```
vSet = pcviewset;
```

Initialize the pose of the first point cloud to an identity rigid transformation, and add it to the view set using `addView`.

```
initAbsPose = rigid3d;
vSet = addView(vSet, currentViewId-1, initAbsPose);
```

Compute the absolute pose of the second point cloud using the relative pose estimated during registration, and add it to the view set.

```
absPose = rigid3d(relPose.T*initAbsPose.T);
vSet = addView(vSet, currentViewId, absPose);
```

Connect the two views using `addConnection`.

```
vSet = addConnection(vSet, currentViewId-1, currentViewId, relPose);
```

Transform the current point cloud to align it to the global map.

```
ptCloud = pctransform(ptCloud, absPose);
```

### Segment Point Cloud and Extract Features

Segment the previous and current point clouds using `segmentLidarData`.

```
labels1 = segmentLidarData(prevPtCloud, distThreshold, angleThreshold, ...
    'NumClusterPoints', minNumPoints);
labels2 = segmentLidarData(ptCloud, distThreshold, angleThreshold, ...
    'NumClusterPoints', minNumPoints);
```

Extract features from the previous and current point cloud segments using `extractEigenFeatures`.

```
[prevFeatures, prevSegments] = extractEigenFeatures(prevPtCloud, labels1);
[features, segments] = extractEigenFeatures(ptCloud, labels2);
```

Track the segments and features using a `pcmapsegmatch` object. Create an empty `pcmapsegmatch`.

```
sMap = pcmapsegmatch;
```

Add the views, features, and segments for the previous and current point clouds to the `pcmapsegmatch` using `addView`.

```
sMap = addView(sMap, currentViewId-1, prevFeatures, prevSegments);
sMap = addView(sMap, currentViewId, features, segments);
```

## Detect Loop Closures

The estimated poses accumulate drift as more point clouds are added to the map. Detecting loop closures helps correct for the accumulated drift and produce a more accurate map.

Detect loop closures using `findPose`.

```
[absPoseMap,loopClosureViewId] = findPose(sMap,absPose);  
isLoopClosure = ~isempty(absPoseMap);
```

If `findPose` detects a loop closure, find the transformation between the current view and the loop closure view and add it to the `pcviewset` object.

Use the absolute pose of the current view without the accumulated drift, `absPoseMap`, and the absolute pose of the loop closure view, `absPoseLoop`, to compute the relative pose between the loop closure poses without the drift.

```
if isLoopClosure  
    absPoseLoop = poses(vSet,loopClosureViewId).AbsolutePose;  
    relPoseLoopToCurrent = rigid3d(absPoseMap.T*invert(absPoseLoop).T);
```

Add the loop closure relative pose as a connection using `addConnection`.

```
    vSet = addConnection(vSet,loopClosureViewId,currentViewId, ...  
        relPoseLoopToCurrent);
```

Correct for the accumulated drift using pose graph optimization. Consider finding more than one loop closure connection before optimizing the poses, since optimizing the pose graph and updating the `pcmapsegmatch` object are both computationally intensive.

Save the poses before optimization. The poses are needed to update the segments and centroid locations in the `pcmapsegmatch` object.

```
    prevPoses = vSet.Views.AbsolutePose;
```

Create a pose graph from the view set using `createPoseGraph`, and optimize the pose graph using `optimizePoseGraph` (Navigation Toolbox).

```
    G = createPoseGraph(vSet);  
    optimG = optimizePoseGraph(G,'g2o-levenberg-marquardt');  
    vSet = updateView(vSet,optimG.Nodes);
```

Find the transformations from the poses before and after correcting for drift and use them to update the map segments and centroid locations using `updateMap`.

```
    optimizedPoses = vSet.Views.AbsolutePose;  
  
    relPoseOpt = rigid3d.empty;  
    for k = 1:numel(prevPoses)  
        relPoseOpt(k) = rigid3d(invert(prevPoses(k)).T* ...  
            optimizedPoses(k).T);  
    end  
  
    sMap = updateMap(sMap,relPoseOpt);  
end
```

To build the map and correct for accumulated drift, apply these steps to the rest of the point cloud scans.



```

% Set the random seed for example reproducibility.
rng(0)

% Update display every 5 scans.
figure
updateRate = 5;

% Initialize variables for registration.
prevPtCloud = ptCloudFiltered;
prevPose = rigid3d;

% Keep track of the loop closures to optimize the poses once enough loop
% closures are detected.
totalLoopClosures = 0;

for i = 3:numel(ptCloudMap)
    ptCloud = ptCloudMap(i);

    % Preprocess and register the point cloud.
    ptCloud = helperPreProcessPointCloud(ptCloud,egoRadius,cylinderRadius);
    ptCloudFiltered = pcdownsampling(ptCloud,'random',downsamplePercent);
    relPose = pregisterndt(ptCloudFiltered,prevPtCloud,gridStep, ...
        'InitialTransform',relPose);
    ptCloud = pctransform(ptCloud,absPose);

    % Store the current point cloud to register the next point cloud.
    prevPtCloud = ptCloudFiltered;

    % Compute the absolute pose of the current point cloud.
    absPose = rigid3d(relPose.T*absPose.T);

    % If the vehicle has moved at least 2 meters since last time, continue
    % with segmentation, feature extraction, and loop closure detection.
    if norm(absPose.Translation-prevPose.Translation) >= 2

        % Segment the point cloud and extract features.
        labels = segmentLidarData(ptCloud,distThreshold,angleThreshold, ...
            'NumClusterPoints',minNumPoints);
        [features,segments] = extractEigenFeatures(ptCloud,labels);

        % Keep track of the current view id.
        currentViewId = currentViewId+1;

        % Add the view to the point cloud view set and map representation.
        vSet = addView(vSet,currentViewId,absPose);
        vSet = addConnection(vSet,currentViewId-1,currentViewId, ...
            rigid3d(absPose.T*invert(prevPose).T));
        sMap = addView(sMap,currentViewId,features,segments);

        % Update the view set display.
        if mod(currentViewId,updateRate) == 0
            plot(vSet)
            drawnow
        end

        % Check if there is a loop closure.
        [absPoseMap,loopClosureViewId] = findPose(sMap,absPose,'MatchThreshold',1, ...
            'MinNumInliers',5,'NumSelectedClusters',4,'NumExcludedViews',150);
    end
end

```

```
isLoopClosure = ~isempty(absPoseMap);

if isLoopClosure
    totalLoopClosures = totalLoopClosures+1;

    % Find the relative pose between the loop closure poses.
    absPoseLoop = poses(vSet,loopClosureViewId).AbsolutePose;
    relPoseLoopToCurrent = rigid3d(absPoseMap.T*invert(absPoseLoop).T);
    vSet = addConnection(vSet,loopClosureViewId,currentViewId, ...
        relPoseLoopToCurrent);

    % Optimize the graph of poses and update the map every time 3
    % loop closures are detected.
    if mod(totalLoopClosures,3) == 0
        prevPoses = vSet.Views.AbsolutePose;

        % Correct for accumulated drift.
        G = createPoseGraph(vSet);
        optimG = optimizePoseGraph(G,'g2o-levenberg-marquardt');
        vSet = updateView(vSet,optimG.Nodes);

        % Update the map.
        optimizedPoses = vSet.Views.AbsolutePose;
        relPoseOpt = rigid3d.empty;
        for k = 1:numel(prevPoses)
            relPoseOpt(k) = rigid3d(invert(prevPoses(k)).T* ...
                optimizedPoses(k).T);
        end
        sMap = updateMap(sMap,relPoseOpt);

        % Update the absolute pose after pose graph optimization.
        absPose = optimizedPoses(end);
    end
end
prevPose = absPose;
end
end
```

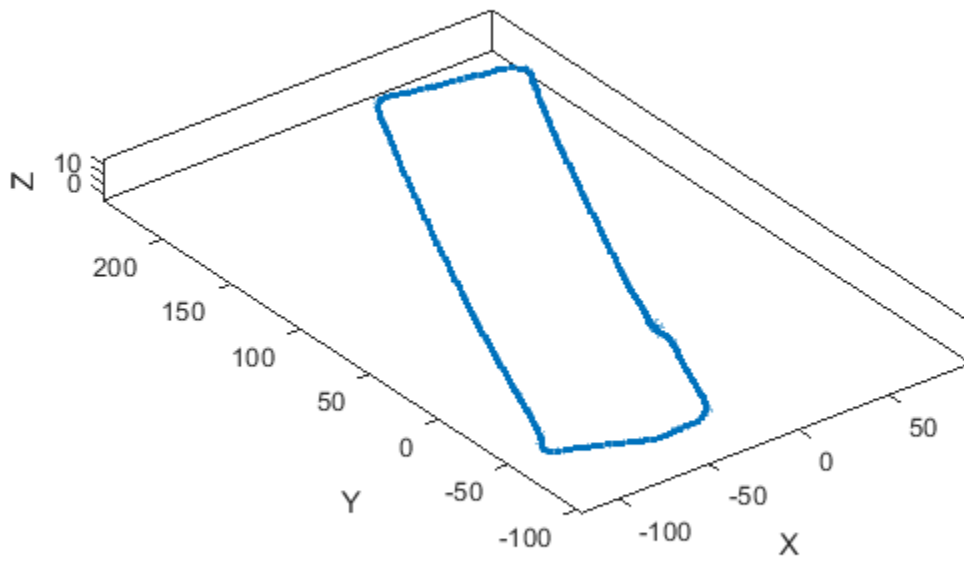

```
% Visualize the map of segments from the top view.  
figure  
show(sMap)  
view(2)  
title('Map of Segments')
```

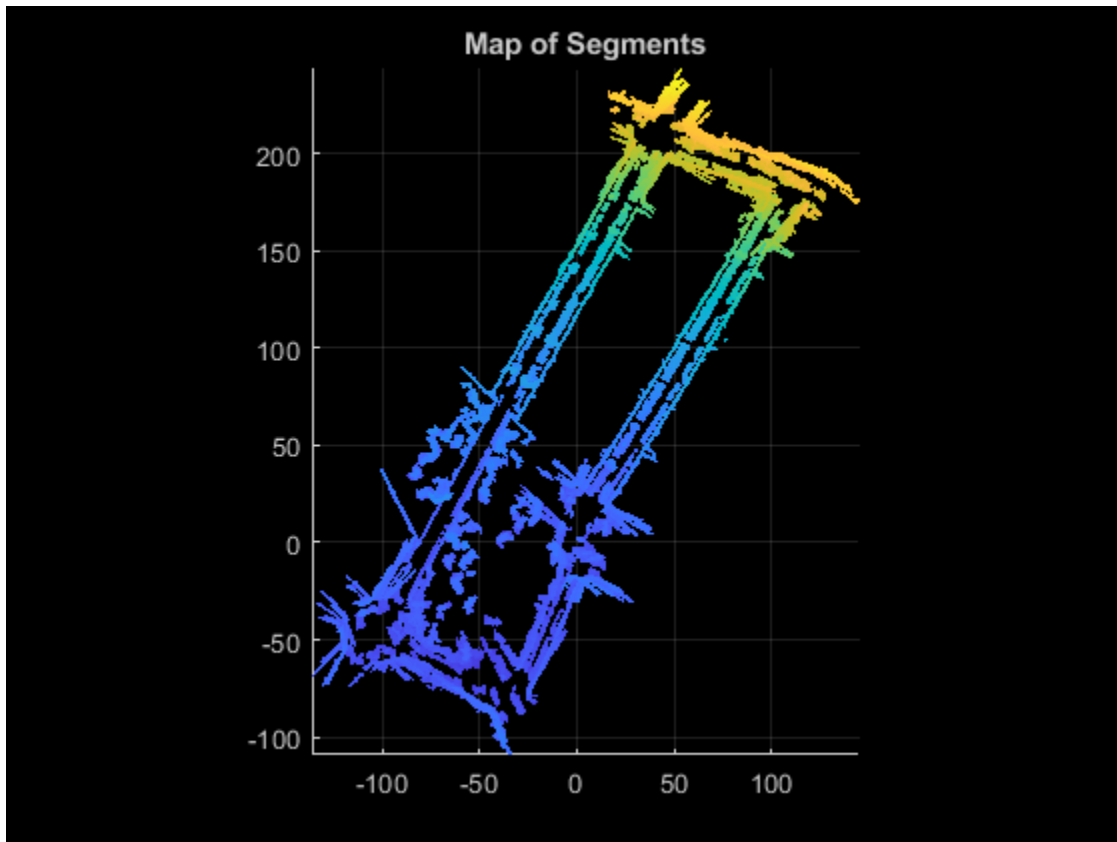

### Localize Vehicle in Known Map

The preprocessing steps for localization using SegMatch are the same preprocessing steps used for map building. Since the algorithm relies on consistent segmentation, use the same segmentation parameters for best results.

```
ptCloud = ptCloudLoc(1);

% Preprocess the point cloud.
ptCloud = helperPreProcessPointCloud(ptCloud, egoRadius, cylinderRadius);

% Segment the point cloud and extract features.
labels = segmentLidarData(ptCloud, distThreshold, angleThreshold, ...
    'NumClusterPoints', minNumPoints);
features = extractEigenFeatures(ptCloud, labels);
```

Because there is no position estimate for the vehicle, you must use the extent of the map for initial vehicle localization. Select the extent of the map to localize for the first time using `selectSubmap`.

```
sMap = selectSubmap(sMap, [sMap.XLimits sMap.YLimits sMap.ZLimits]);
```

Use the `findPose` object function of `pcmapsegmatch` to localize the vehicle on the prebuilt map.

```
absPoseMap = findPose(sMap, features, 'MatchThreshold', 1, 'MinNumInliers', 5);
```

Visualize the map, and use `showShape` to visualize the vehicle on the map as a cuboid.

```
mapSegments = pccat(sMap.Segments);
hAxLoc = pcshow(mapSegments.Location, 'p');
```

```

title('Localization on a Prebuilt Map')
view(2)

poseTranslation = absPoseMap.Translation;
quat = quaternion(absPoseMap.Rotation', 'rotmat', 'point');
theta = eulerd(quat, 'ZYX', 'point');
pos = [poseTranslation 5 9 3.5 theta(2) theta(3) theta(1)];
showShape('cuboid', pos, 'Color', 'green', 'Parent', hAxLoc, 'Opacity', 0.8, 'LineWidth', 0.5)

```

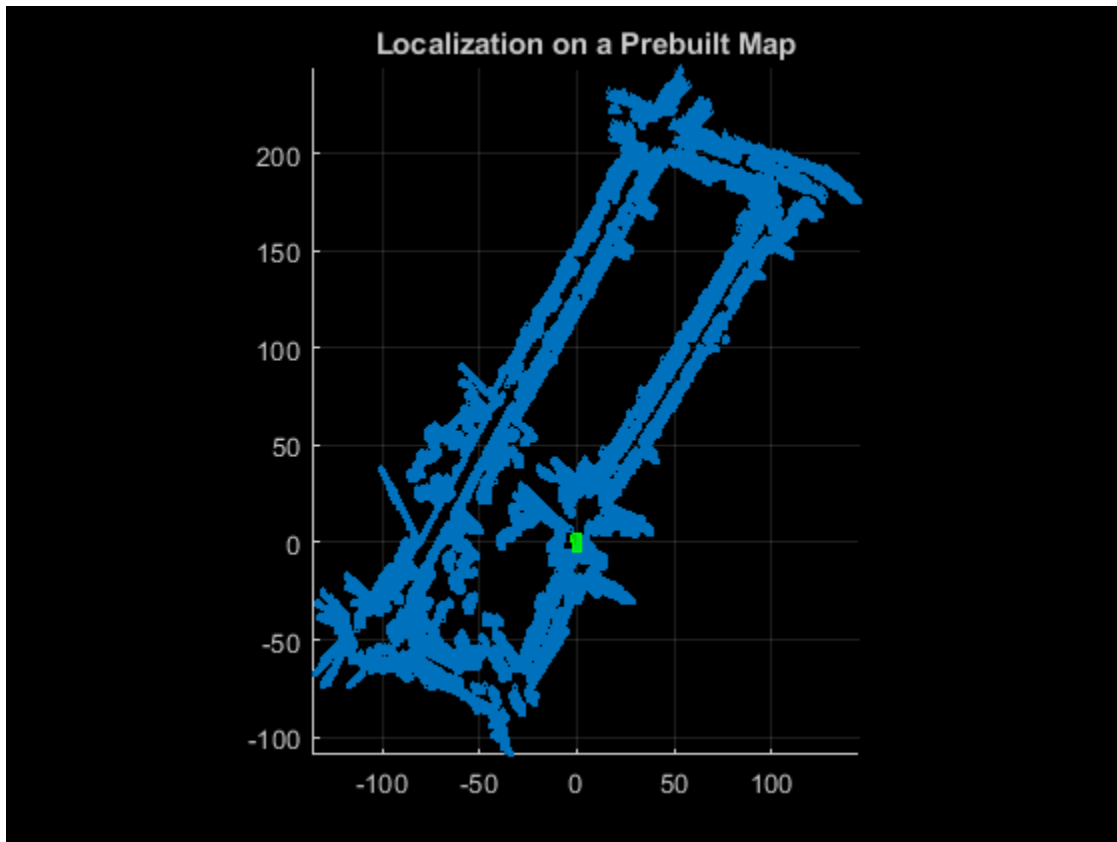

To improve localization speed for the rest of the scans, select a submap using `selectSubmap`.

```

submapSize = [65 65 200];
sMap = selectSubmap(sMap, poseTranslation, submapSize);

```

Continue localizing the vehicle using the rest of the point cloud scans. Use `isInsideSubmap` and `selectSubmap` to keep the submap updated. If there are not enough segments to localize the vehicle using segment matching, use registration to estimate the pose.

```

% Visualize the map.
figure('Visible','on')
hAx = pcshow(mapSegments.Location, 'p');
title('Localization on a Prebuilt Map')

% Set parameter to update submap.
submapThreshold = 30;

% Initialize the poses and previous point cloud for registration.
prevPtCloud = ptCloud;

```

```
relPose = rigid3d;
prevAbsPose = rigid3d;

% Segment each point cloud and localize by finding segment matches.
for n = 2:numel(ptCloudLoc)
    ptCloud = ptCloudLoc(n);

    % Preprocess the point cloud.
    ptCloud = helperPreProcessPointCloud(ptCloud,egoRadius,cylinderRadius);

    % Segment the point cloud and extract features.
    labels = segmentLidarData(ptCloud,distThreshold,angleThreshold, ...
        'NumClusterPoints',minNumPoints);
    features = extractEigenFeatures(ptCloud,labels);

    % Localize the point cloud.
    absPoseMap = findPose(sMap,features,'MatchThreshold',1,'MinNumInliers',5);

    % Do registration when the position cannot be estimated with segment
    % matching.
    if isempty(absPoseMap)
        relPose = pcregisterndt(ptCloud,prevPtCloud,gridStep, ...
            'InitialTransform',relPose);
        absPoseMap = rigid3d(relPose.T*prevAbsPose.T);
    end

    % Display position estimate in the map.
    poseTranslation = absPoseMap.Translation;
    quat = quaternion(absPoseMap.Rotation','rotmat','point');
    theta = eulder(quat,'ZYX','point');
    pos = [poseTranslation 5 9 3.5 theta(2) theta(3) theta(1)];
    showShape('cuboid',pos,'Color','green','Parent',hAx,'Opacity',0.8,'LineWidth',0.5)

    % Determine if selected submap needs to be updated.
    [isInside,distToEdge] = isInsideSubmap(sMap,poseTranslation);
    needSelectSubmap = ~isInside ... % Current pose is outside submap.
        || any(distToEdge(1:2) < submapThreshold); % Current pose is close to submap edge

    % Select a new submap.
    if needSelectSubmap
        sMap = selectSubmap(sMap,poseTranslation,submapSize);
    end

    prevAbsPose = absPoseMap;
    prevPtCloud = ptCloud;
end
```

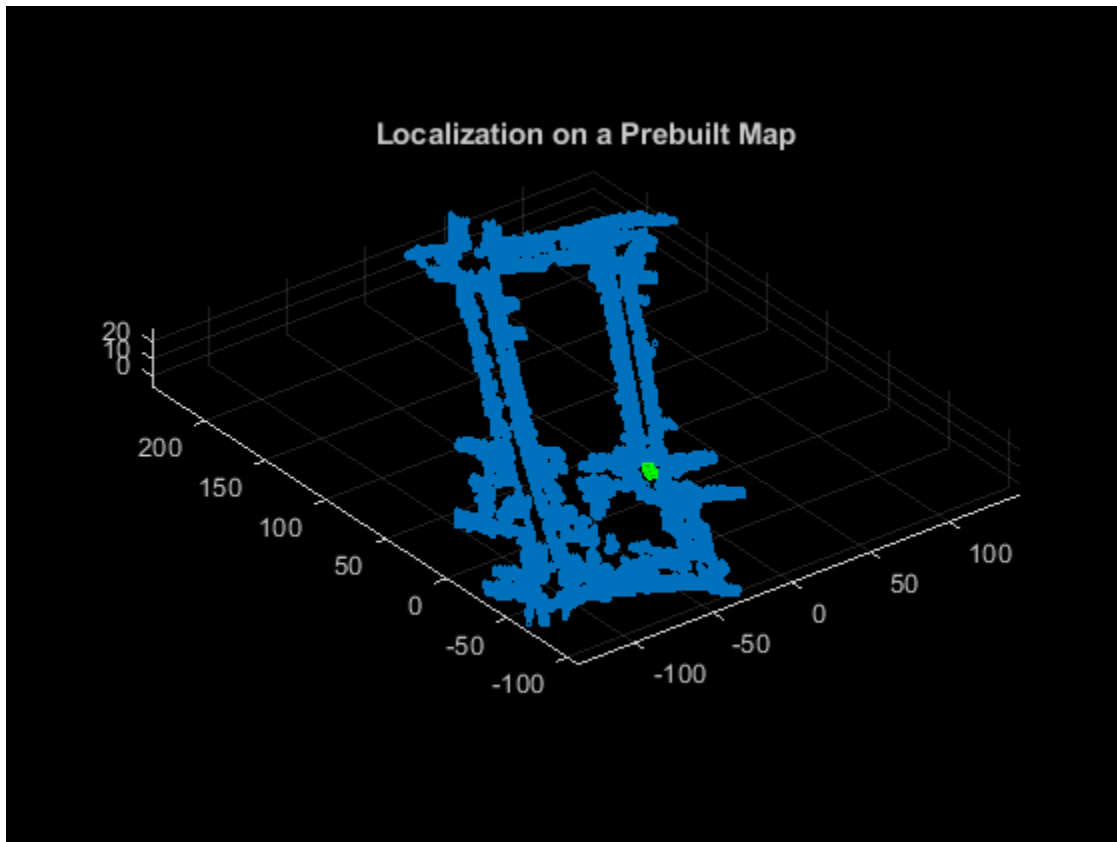

## References

[1] R. Dube, D. Dugas, E. Stumm, J. Nieto, R. Siegwart, and C. Cadena. "SegMatch: Segment Based Place Recognition in 3D Point Clouds." IEEE International Conference on Robotics and Automation (ICRA), 2017.

## Supporting Functions

**helperReadVelodyneSLAMData** reads point clouds from PNG image files from the Velodyne SLAM Dataset.

**helperPreProcessPointCloud** selects a cylindrical neighborhood and removes the ground from a point cloud.

```
function ptCloud = helperPreProcessPointCloud(ptCloud,egoRadius,cylinderRadius)
```

```
% Compute the distance between each point and the origin.
dists = hypot(ptCloud.Location(:, :, 1), ptCloud.Location(:, :, 2));
```

```
% Select the points inside the cylinder radius and outside the ego radius.
cylinderIdx = dists <= cylinderRadius & dists >= egoRadius;
ptCloud = select(ptCloud, cylinderIdx, 'OutputSize', 'full');
```

```
% Remove ground.
[~, ptCloud] = segmentGroundSMRF(ptCloud, 'ElevationThreshold', 0.05);
```

end



## Lidar and Camera Calibration

This example shows you how to estimate a rigid transformation between a 3-D lidar sensor and a camera, then use the rigid transformation matrix to fuse the lidar and camera data.

### Overview

Lidar sensors and cameras are commonly used together in autonomous driving applications because a lidar sensor collects 3-D spatial information while a camera captures the appearance and texture of that space in 2-D images. You can fuse the data from these sensors to improve your object detection and classification. Lidar-camera calibration estimates a transformation matrix that gives the relative rotation and translation between the two sensors. You use this matrix when performing lidar-camera data fusion.

This diagram illustrates the workflow for the lidar and camera calibration (LCC) process, where we use checkerboard as a calibration object. We extract the checkerboard corners and planes from lidar and camera data, then establish a geometrical relationship between their coordinate systems to perform calibration. For more information on lidar-camera calibration process, see “What Is Lidar-Camera Calibration?” on page 4-10

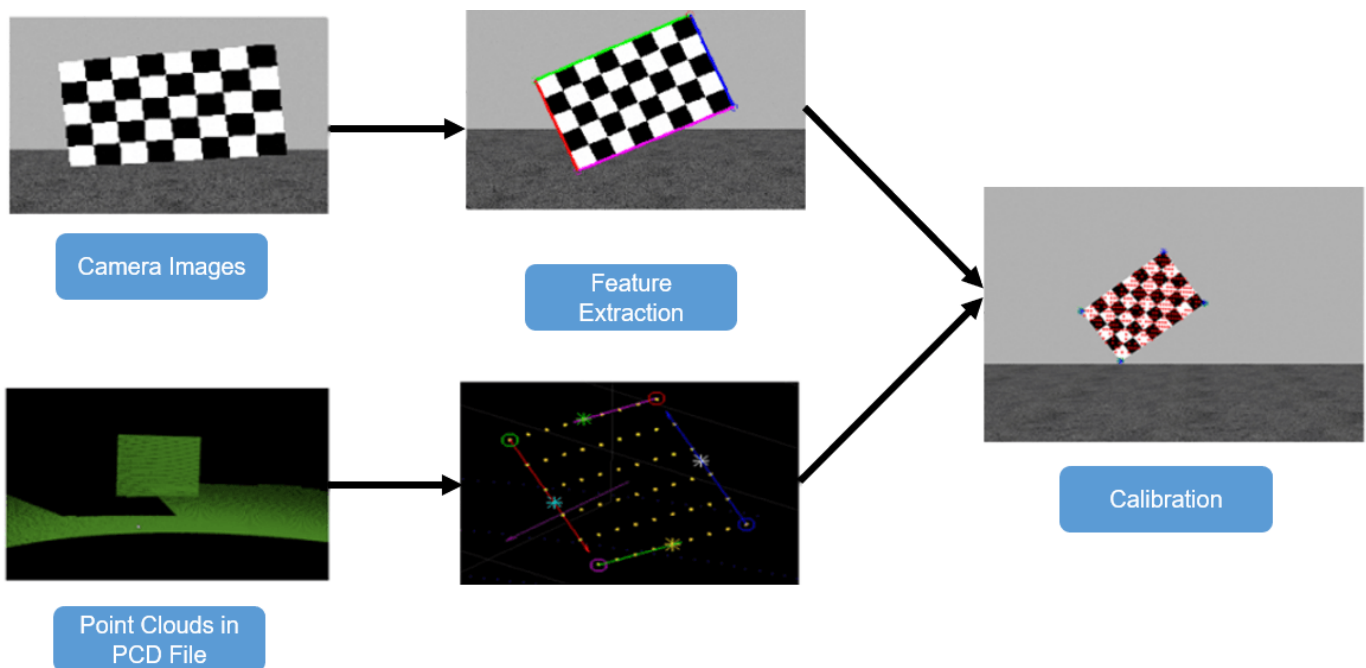

This example uses data from two different lidar sensors, a *VelodyneLiDAR*® HDL-64 sensor and a *VelodyneLiDAR*® VLP-16 sensor. For the HDL-64 sensor, use data collected from a Gazebo environment.

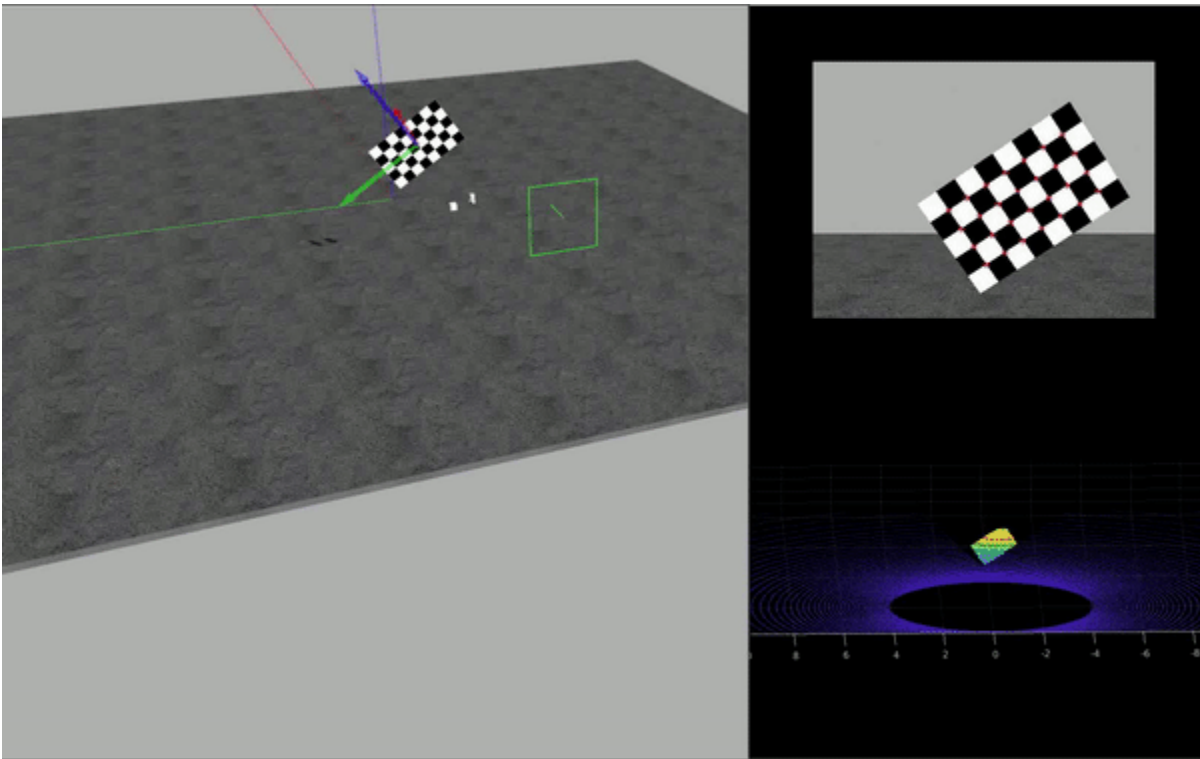

The HDL-64 sensor captures data as a set of PNG images and corresponding PCD point clouds. This example assumes that you already know the intrinsic parameters of the camera. For more information on extracting camera intrinsic parameters, see “Evaluating the Accuracy of Single Camera Calibration”.

### Load Data

Load the Velodyne HDL-64 sensor data from Gazebo.

```
imagePath = fullfile(toolboxdir('lidar'),'lidardata','lcc','HDL64','images');
ptCloudPath = fullfile(toolboxdir('lidar'),'lidardata','lcc','HDL64','pointCloud');
cameraParamsPath = fullfile(imagePath,'calibration.mat');
```

```
% Load camera intrinsics.
```

```
intrinsic = load(cameraParamsPath);
```

```
% Load images using imageDatastore.
```

```
imds = imageDatastore(imagePath);
```

```
imageFileNames = imds.Files;
```

```
% Load point cloud files.
```

```
pcds = fileDatastore(ptCloudPath,'ReadFcn',@pcread);
```

```
ptCloudFileNames = pcds.Files;
```

```
% Square size of the checkerboard.
```

```
squareSize = 200;
```

```
% Set random seed to generate reproducible results.
```

```
rng('default')
```

## Detect Checkerboard Corners

This example uses a checkerboard pattern for calibration. First, estimate the checkerboard edges from the camera data. Use the `estimateCheckerboardCorners3d` function to calculate the coordinates of the checkerboard corners and size of the actual checkerboard in millimeters. The function estimates corners as 3-D coordinates in world coordinate system.

```
[imageCorners3d,checkerboardDimension,dataUsed] = ...
    estimateCheckerboardCorners3d(imageFileNames,intrinsic.cameraParams,squareSize);
```

```
% Remove image files that are not used.
imageFileNames = imageFileNames(dataUsed);
```

Visualize the results by using the `helperShowImageCorners` helper function.

```
% Display checkerboard corners.
helperShowImageCorners(imageCorners3d,imageFileNames,intrinsic.cameraParams)
```

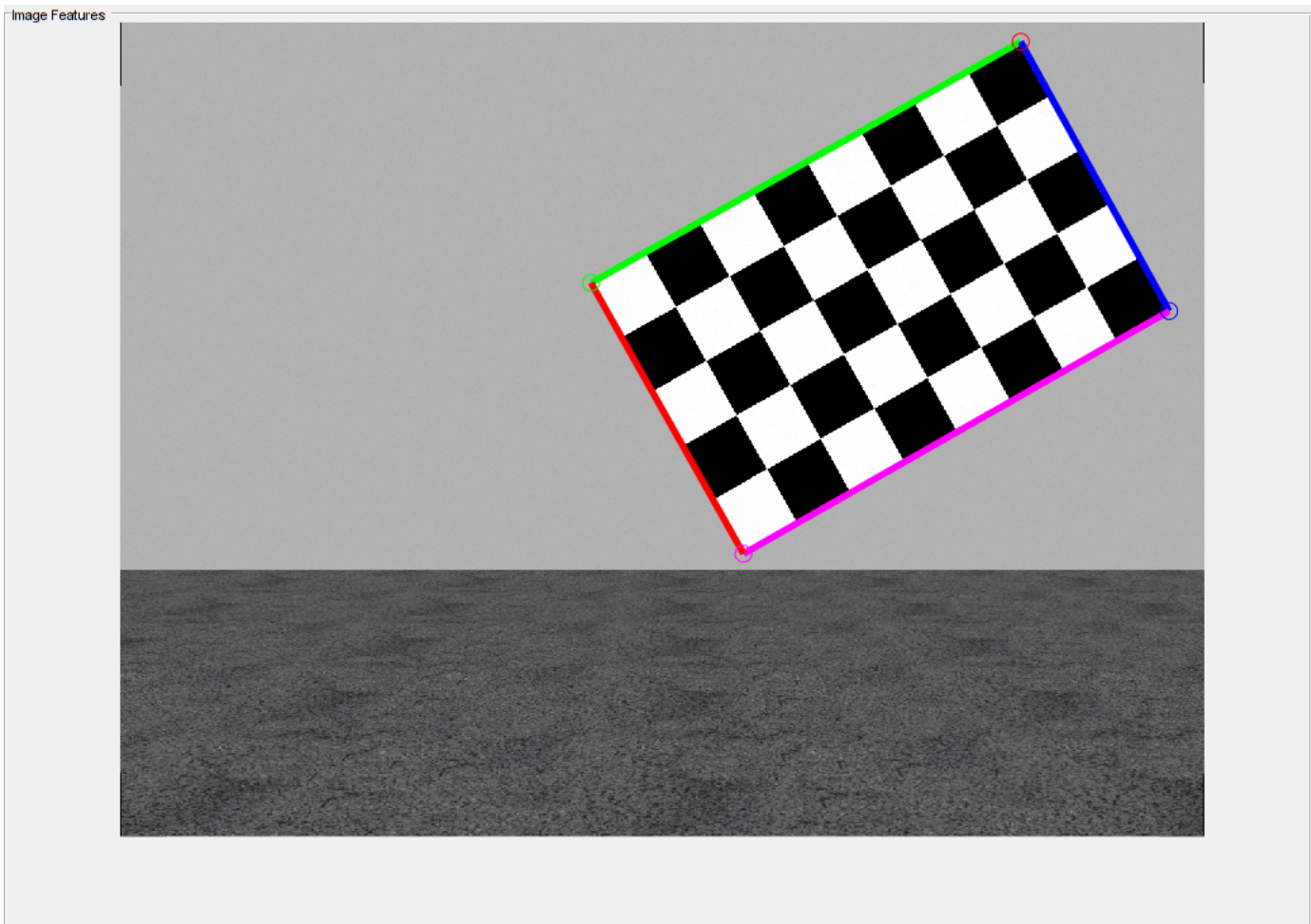

## Detect Checkerboard Plane

Next, use the `detectRectangularPlanePoints` function to detect the checkerboard plane in the lidar data. The function detects the checkerboard using the board dimensions calculated by the `estimateCheckerboardCorners3d` function.

```
% Extract the checkerboard ROI from the detected checkerboard image corners.
roi = helperComputeROI(imageCorners3d,5);

% Filter the point cloud files that are not used for detection.
ptCloudFileNames = ptCloudFileNames(dataUsed);
[lidarCheckerboardPlanes,framesUsed,indices] = ...
    detectRectangularPlanePoints(ptCloudFileNames,checkerboardDimension,ROI=roi);

% Remove ptCloud files that are not used.
ptCloudFileNames = ptCloudFileNames(framesUsed);

% Remove image files.
imageFileNames = imageFileNames(framesUsed);

% Remove 3-D corners from images.
imageCorners3d = imageCorners3d(:,:,framesUsed);
```

Visualize the detected checkerboard by using the `helperShowCheckerboardPlanes` function.

```
helperShowCheckerboardPlanes(ptCloudFileNames,indices)
```

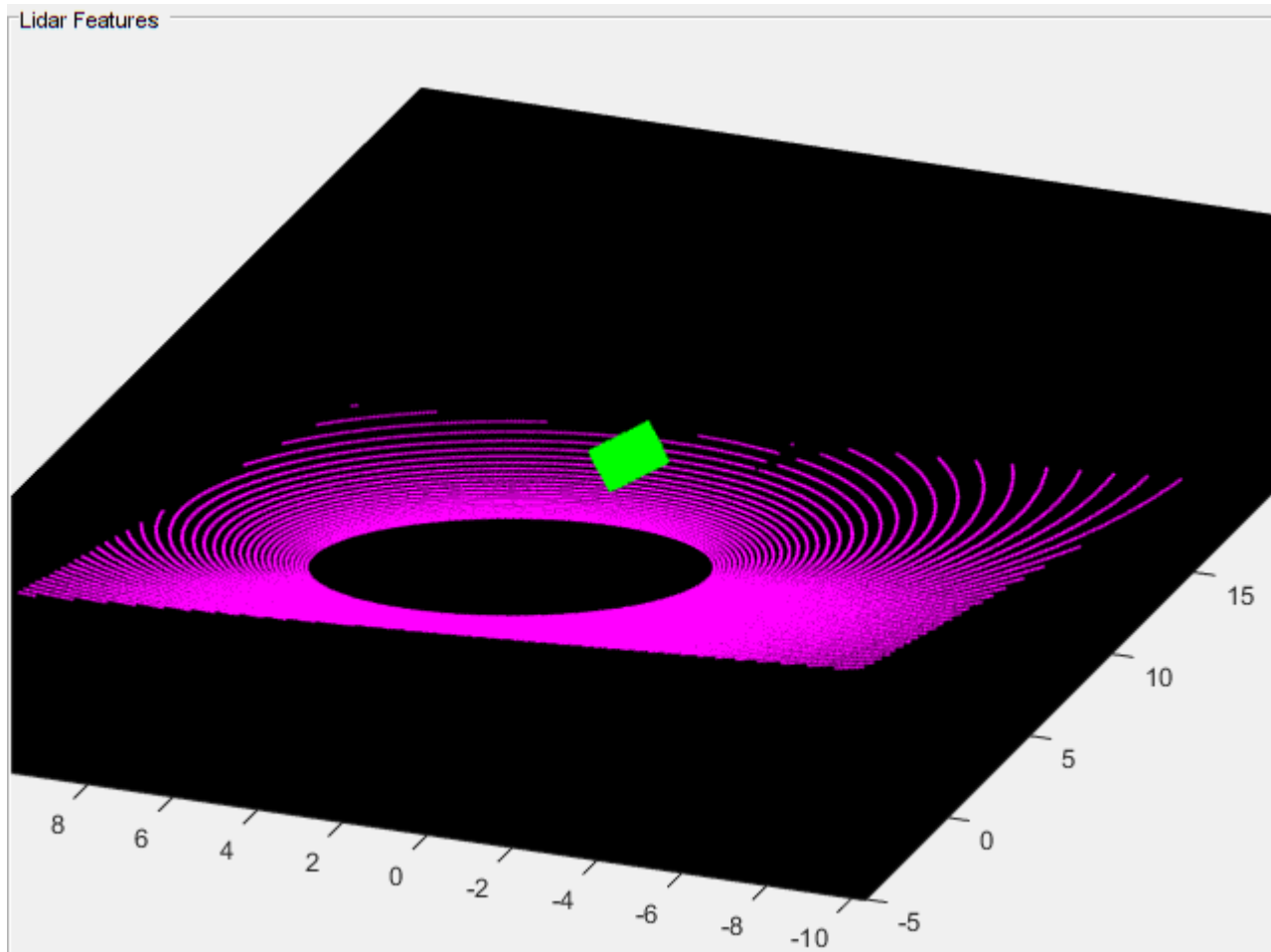

## Calibrate Lidar and Camera

Use the `estimateLidarCameraTransform` function to estimate the rigid transformation matrix between the lidar sensor and the camera.

```
[tform,errors] = estimateLidarCameraTransform(lidarCheckerboardPlanes, ...
    imageCorners3d,intrinsic.cameraParams);
```

After calibration, you can use this transformation matrix to:

- Project lidar point clouds on images, using the `projectLidarPointsOnImage` function.
- Enhance lidar point clouds using color information from images, using the `fuseCameraToLidar` function.

Use the `helperFuseLidarCamera` function to visualize the lidar and the image data fused together.

```
helperFuseLidarCamera(imageFileNames,ptCloudFileNames,indices, ...
    intrinsic.cameraParams,tform);
```

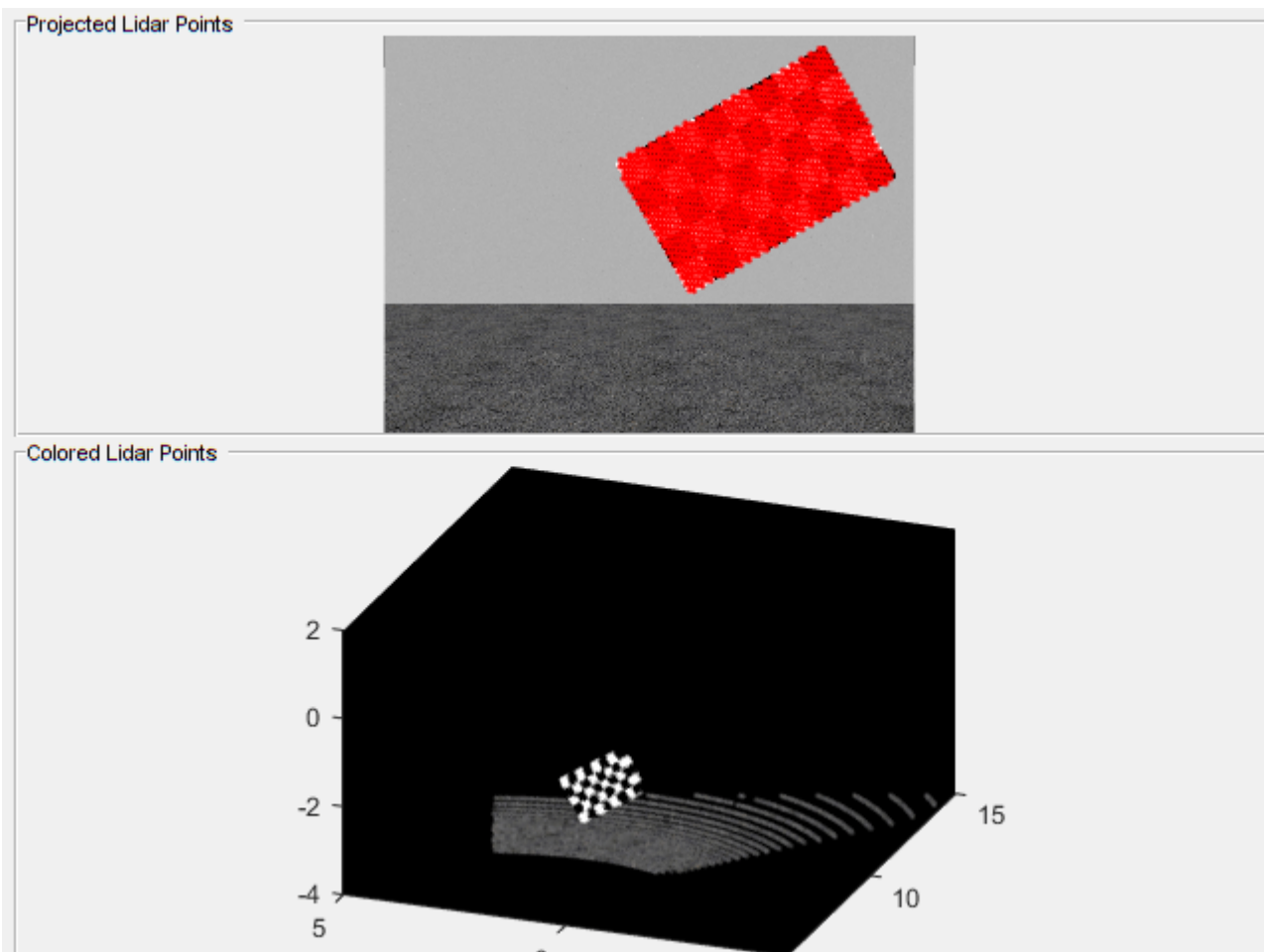

## Visualize Calibration Errors

You can estimate the calibration accuracy using these types of errors.

- Translation Error — The difference between the centroid coordinates of the checkerboard planes in the point clouds and those in the corresponding images, in meters.
- Rotation Error — The difference between the normal angles defined by the checkerboard planes in the point clouds and those in the corresponding images, in radians.
- Reprojection Error — The difference between the projected (transformed) centroid coordinates of the checkerboard planes from the point clouds and those in the corresponding images, in pixels.

Plot the estimated error values by using the `helperShowError` function.

```
helperShowError(errors)
```



## Calibration on Real Data

Test the LCC workflow on actual VLP-16 lidar data to evaluate its performance.

```
clear
imagePath = fullfile(toolboxdir('lidar'),'lidardata','lcc','vlp16','images');
ptCloudPath = fullfile(toolboxdir('lidar'),'lidardata','lcc','vlp16','pointCloud');
cameraParamsPath = fullfile(imagePath,'calibration.mat');

% Load camera intrinsics.
intrinsic = load(cameraParamsPath);

% Load images using imageDatastore.
imds = imageDatastore(imagePath);
imageFileNames = imds.Files;

% Load point cloud files.
pcds = fileDatastore(ptCloudPath,'ReadFcn',@pcread);
ptCloudFileNames = pcds.Files;
```

```
% Square size of the checkerboard in mm.
squareSize = 81;

% Set random seed to generate reproducible results.
rng('default')

% Extract checkerboard corners from the images.
[imageCorners3d,checkerboardDimension,dataUsed] = ...
    estimateCheckerboardCorners3d(imageFileNames,intrinsic.cameraParams,squareSize);

% Remove the unused image files.
imageFileNames = imageFileNames(dataUsed);

% Filter the point cloud files that are not used for detection.
ptCloudFileNames = ptCloudFileNames(dataUsed);

% Extract ROI from the detected checkerboard image corners.
roi = helperComputeROI(imageCorners3d,5);

% Extract checkerboard plane from point cloud data.
[lidarCheckerboardPlanes,framesUsed,indices] = detectRectangularPlanePoints( ...
    ptCloudFileNames,checkerboardDimension,RemoveGround=true,ROI=roi);
imageCorners3d = imageCorners3d(:,:,framesUsed);

% Remove ptCloud files that are not used.
ptCloudFileNames = ptCloudFileNames(framesUsed);

% Remove image files that are not used.
imageFileNames = imageFileNames(framesUsed);

[tform,errors] = estimateLidarCameraTransform(lidarCheckerboardPlanes, ...
    imageCorners3d,intrinsic.cameraParams);
helperFuseLidarCamera(imageFileNames,ptCloudFileNames,indices, ...
    intrinsic.cameraParams,tform);
```

Projected Lidar Points



Colored Lidar Points

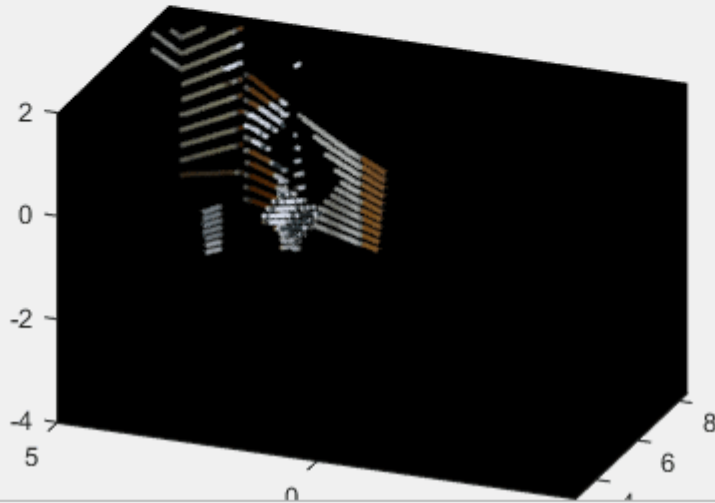

```
% Plot the estimated error values.  
helperShowError(errors);
```





## Summary

This example provides an overview of the lidar-camera calibration workflow and shows you how to use a rigid transformation matrix to fuse lidar and camera data.

## References

- [1] Zhou, Lipu, Zimo Li, and Michael Kaess. "Automatic Extrinsic Calibration of a Camera and a 3D LiDAR Using Line and Plane Correspondences." In 2018 IEEE/RSJ International Conference on Intelligent Robots and Systems (IROS), 5562-69. Madrid: IEEE, 2018. <https://doi.org/10.1109/IROS.2018.8593660>.
- [2] Arun, K. S., T. S. Huang, and S. D. Blostein. "Least-Squares Fitting of Two 3-D Point Sets." IEEE Transactions on Pattern Analysis and Machine Intelligence PAMI-9, no. 5 (September 1987): 698-700. <https://doi.org/10.1109/TPAMI.1987.4767965>.

## Lidar Point Cloud Semantic Segmentation Using PointSeg Deep Learning Network

This example shows how to train a PointSeg semantic segmentation network on 3-D organized lidar point cloud data.

PointSeg [1 on page 1-0 ] is a convolutional neural network (CNN) for performing end-to-end semantic segmentation of road objects based on an organized lidar point cloud. By using methods such as atrous spatial pyramid pooling (ASPP) and squeeze-and-excitation blocks, the network provides improved segmentation results. The training procedure shown in this example requires 2-D spherical projected images as inputs to the deep learning network.

This example uses a highway scene data set collected using an Ouster OS1 sensor. It contains organized lidar point cloud scans of highway scenes and corresponding ground truth labels for car and truck objects. The size of the data file is approximately 760 MB.

### Download Lidar Data Set

Execute this code to download the highway scene data set. The data set contains 1617 point clouds stored as `pointCloud` objects in a cell array. Corresponding ground truth data, which is attached to the example, contains bounding box information of cars and trucks in each point cloud.

```
url = 'https://www.mathworks.com/supportfiles/lidar/data/WPI_LidarData.tar.gz';

outputFolder = fullfile(tempdir, 'WPI');
lidarDataTarFile = fullfile(outputFolder, 'WPI_LidarData.tar.gz');

if ~exist(lidarDataTarFile, 'file')
    mkdir(outputFolder);

    disp('Downloading WPI Lidar driving data (760 MB)...');
    websave(lidarDataTarFile, url);
    untar(lidarDataTarFile, outputFolder);
end

% Check if tar.gz file is downloaded, but not uncompressed.
if ~exist(fullfile(outputFolder, 'WPI_LidarData.mat'), 'file')
    untar(lidarDataTarFile, outputFolder);
end
lidarData = load(fullfile(outputFolder, 'WPI_LidarData.mat'));

groundTruthData = load('WPI_LidarGroundTruth.mat');
```

Note: Depending on your Internet connection, the download process can take some time. The code suspends MATLAB® execution until the download process is complete. Alternatively, you can download the data set to your local disk using your web browser, and then extract `WPI_LidarData`. To use the file you downloaded from the web, change the `outputFolder` variable in the code to the location of the downloaded file.

### Download Pretrained Network

Download the pretrained network to avoid having to wait for training to complete. If you want to train the network, set the `doTraining` variable to true.

```
doTraining = false;
if ~doTraining && ~exist('trainedPointSegNet.mat', 'file')
```

```

disp('Downloading pretrained network (14 MB)...');
pretrainedURL = 'https://www.mathworks.com/supportfiles/lidar/data/trainedPointSegNet.mat';
websave('trainedPointSegNet.mat', pretrainedURL);
end

```

Downloading pretrained network (14 MB)...

## Prepare Data for Training

### Load Lidar Point Clouds and Class Labels

Use the `helperGenerateTrainingData` supporting function, attached to this example, to generate training data from the lidar point clouds. The function uses point cloud and bounding box data to create five-channel input images and pixel label images. To create the pixel label images, the function selects points inside the bounding box and labels them with the bounding box class ID. Each training image is specified as a 64-by-1024-by-5 array:

- The height of each image is 64 pixels.
- The width of each image is 1024 pixels.
- Each image has 5 channels. The five channels specify the 3-D coordinates of the point cloud, intensity, and range:  $r = \sqrt{x^2 + y^2 + z^2}$ .

A visual representation of the training data follows.



Generate the five-channel training images and pixel label images.

```

imagesFolder = fullfile(outputFolder, 'images');
labelsFolder = fullfile(outputFolder, 'labels');

helperGenerateTrainingData(lidarData, groundTruthData, imagesFolder, labelsFolder);

```

Preprocessing data 100.00% complete

The five-channel images are saved as MAT files. Pixel labels are saved as PNG files.

Note: Processing can take some time. The code suspends MATLAB® execution until processing is complete.

## Create ImageDatastore and PixelLabelDatastore

Use the `imageDatastore` object to extract and store the five channels of the 2-D spherical images using the `helperImageMatReader` supporting function, which is a custom MAT file reader. This function is attached to this example as a supporting file.

```
imds = imageDatastore(imagesFolder, ...
    'FileExtensions', '.mat', ...
    'ReadFcn', @helperImageMatReader);
```

Use the `pixelLabelDatastore` object to store pixel-wise labels from the label images. The object maps each pixel label to a class name. In this example, cars and trucks are the only objects of interest; all other pixels are the background. Specify these classes (car, truck, and background) and assign a unique label ID to each class.

```
classNames = [
    "background"
    "car"
    "truck"
];
```

```
numClasses = numel(classNames);
```

```
% Specify label IDs from 1 to the number of classes.
labelIDs = 1 : numClasses;
```

```
pxds = pixelLabelDatastore(labelsFolder, classNames, labelIDs);
```

Load and display one of the labeled images by overlaying it on the corresponding intensity image using the `helperDisplayLidarOverlayImage` function, defined in the Supporting Functions on page 1-0 section of this example.

```
imageNumber = 225;
```

```
% Point cloud (channels 1, 2, and 3 are for location, channel 4 is for intensity).
I = readimage(imds, imageNumber);
```

```
labelMap = readimage(pxds, imageNumber);
figure;
helperDisplayLidarOverlayImage(I, labelMap, classNames);
title('Ground Truth');
```



## Prepare Training, Validation, and Test Sets

Use the `helperPartitionLidarData` supporting function, attached to this example, to split the data into training, validation, and test sets that contain 970, 216, and 431 images, respectively.

```
[imdsTrain, imdsVal, imdsTest, pxdsTrain, pxdsVal, pxdsTest] = ...
    helperPartitionLidarData(imds, pxds);
```

Use the `combine` function to combine the pixel and image datastores for the training and validation data sets.

```
trainingData = combine(imdsTrain, pxdsTrain);
validationData = combine(imdsVal, pxdsVal);
```

### Data Augmentation

Data augmentation is used to improve network accuracy by randomly transforming the original data during training. By using data augmentation, you can add more variety to the training data without actually having to increase the number of labeled training samples.

Augment the training data using the `transform` function with custom preprocessing operations specified by the `augmentData` function, defined in the Supporting Functions on page 1-0 section of this example. This function randomly flips the spherical 2-D image and associated labels in the horizontal direction. Apply data augmentation to only the training data set.

```
augmentedTrainingData = transform(trainingData, @(x) augmentData(x));
```

### Balance Classes Using Class Weighting

To see the distribution of class labels in the data set, use the `countEachLabel` function.

```
tbl = countEachLabel(pxds);
tbl(:, {'Name', 'PixelCount', 'ImagePixelCount'})
```

```
ans=3x3 table
      Name          PixelCount      ImagePixelCount
    _____  _____  _____
    {'background'}  1.0473e+08    1.0597e+08
    {'car'         }  9.7839e+05    8.4738e+07
    {'truck'       }  2.6017e+05    1.9726e+07
```

The classes in this data set are imbalanced, which is a common issue in automotive data sets containing street scenes. The background class covers more area than the car and truck classes. If not handled correctly, this imbalance can be detrimental to the learning process because the learning is biased in favor of the dominant classes.

Use these weights to correct the class imbalance. Use the pixel label counts from the `tbl.PixelCount` property and calculate the median frequency class weights.

```
imageFreq = tbl.PixelCount ./ tbl.ImagePixelCount;
classWeights = median(imageFreq) ./ imageFreq
```

```
classWeights = 3x1
    0.0133
    1.1423
    1.0000
```

### Define Network Architecture

Create a PointSeg network using the `createPointSeg` supporting function, which is attached to the example. The code returns the layer graph that you use to train the network.

```
inputSize = [64 1024 5];  
  
lgraph = createPointSeg(inputSize, classNames, classWeights);
```

Use the `analyzeNetwork` (Deep Learning Toolbox) function to display an interactive visualization of the network architecture.

```
analyzeNetwork(lgraph)
```

### Specify Training Options

Use the `rmsprop` optimization algorithm to train the network. Specify the hyperparameters for the algorithm by using the `trainingOptions` function.

```
maxEpochs = 30;  
initialLearningRate = 5e-4;  
miniBatchSize = 8;  
l2reg = 2e-4;  
  
options = trainingOptions('rmsprop', ...  
    'InitialLearnRate', initialLearningRate, ...  
    'L2Regularization', l2reg, ...  
    'MaxEpochs', maxEpochs, ...  
    'MiniBatchSize', miniBatchSize, ...  
    'LearnRateSchedule', 'piecewise', ...  
    'LearnRateDropFactor', 0.1, ...  
    'LearnRateDropPeriod', 10, ...  
    'ValidationData', validationData, ...  
    'Plots', 'training-progress', ...  
    'VerboseFrequency', 20);
```

Note: Reduce `miniBatchSize` to control memory usage when training.

### Train Network

Use the `trainNetwork` (Deep Learning Toolbox) function to train a PointSeg network if `doTraining` is true. Otherwise, load the pretrained network.

If you train the network, you can use a CPU or a GPU. Using a GPU requires Parallel Computing Toolbox™ and a CUDA® enabled NVIDIA® GPU. For more information, see “GPU Support by Release” (Parallel Computing Toolbox).

```
if doTraining  
    [net, info] = trainNetwork(trainingData, lgraph, options);  
else  
    pretrainedNetwork = load('trainedPointSegNet.mat');  
    net = pretrainedNetwork.net;  
end
```

### Predict Results on Test Point Cloud

Use the trained network to predict results on a test point cloud and display the segmentation result.

First, read a PCD file and convert the point cloud to a five-channel input image. Predict the labels using the trained network. Display the figure with the segmentation as an overlay.

```
ptCloud = pcread('ousterLidarDrivingData.pcd');  
I = helperPointCloudToImage(ptCloud);  
predictedResult = semanticseg(I, net);  
  
figure;  
helperDisplayLidarOverlayImage(I, predictedResult, classNames);  
title('Semantic Segmentation Result');
```



Use the `helperDisplayLidarOverlayPointCloud` helper function, defined in the Supporting Functions on page 1-0 section of this example, to display the segmentation result over the 3-D point cloud object `ptCloud`.

```
figure;  
helperDisplayLidarOverlayPointCloud(ptCloud, predictedResult, numClasses);  
view([95.71 24.14])  
title('Semantic Segmentation Result on Point Cloud');
```

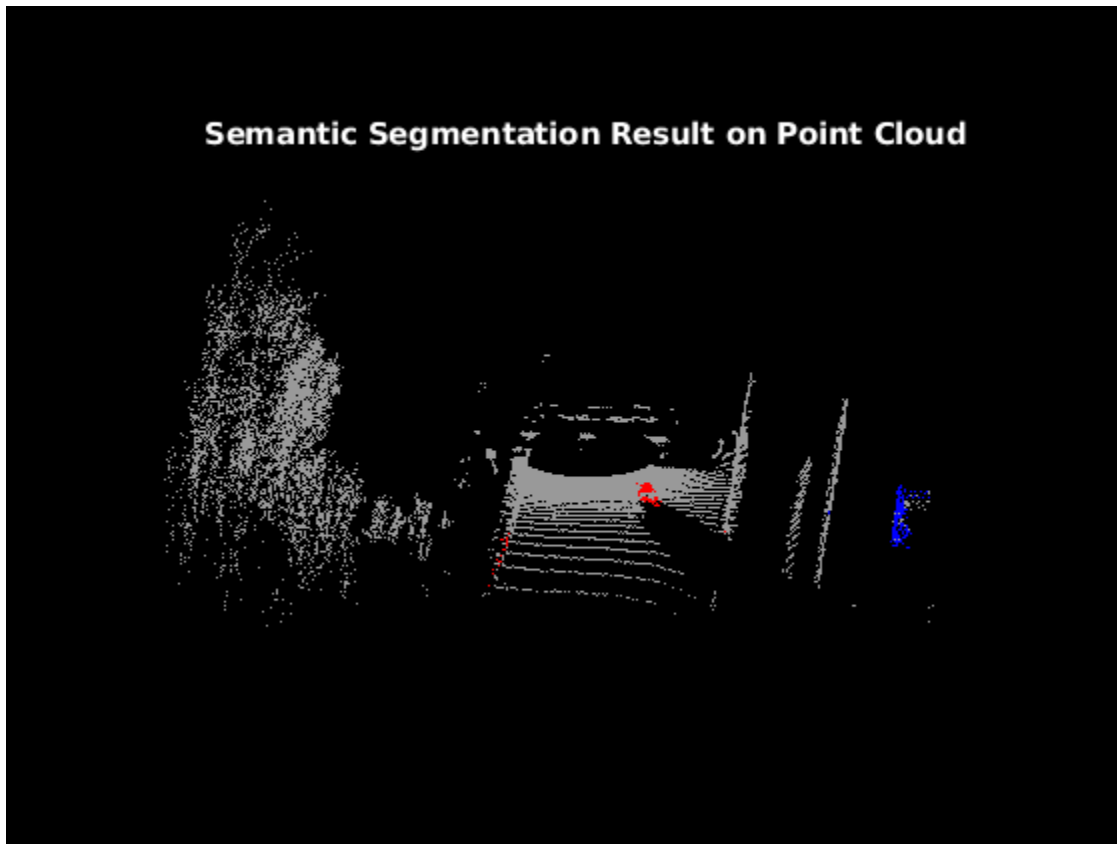

### Evaluate Network

Run the `semanticseg` function on the entire test set to measure the accuracy of the network. Set `MiniBatchSize` to a value of 8 to reduce memory usage when segmenting images. You can increase or decrease this value depending on the amount of GPU memory you have on your system.

```
outputLocation = fullfile(tempdir, 'output');  
if ~exist(outputLocation, 'dir')  
    mkdir(outputLocation);  
end  
pxdsResults = semanticseg(imdsTest, net, ...  
    'MiniBatchSize', 8, ...  
    'WriteLocation', outputLocation, ...  
    'Verbose', false);
```

The `semanticseg` function returns the segmentation results on the test data set as a `PixelLabelDatastore` object. The function writes the actual pixel label data for each test image in the `imdsTest` object to the disk in the location specified by the `'WriteLocation'` argument.

Use the `evaluateSemanticSegmentation` function to compute the semantic segmentation metrics from the test set results.

```
metrics = evaluateSemanticSegmentation(pxdsResults, pxdsTest, 'Verbose', false);
```

You can measure the amount of overlap per class using the intersection-over-union (IoU) metric.



The `evaluateSemanticSegmentation` function returns metrics for the entire data set, for individual classes, and for each test image. To see the metrics at the data set level, use the `metrics.DataSetMetrics` property.

`metrics.DataSetMetrics`

```
ans=1x5 table
   GlobalAccuracy   MeanAccuracy   MeanIoU   WeightedIoU   MeanBFScore
   _____   _____   _____   _____   _____
           0.99209           0.83752           0.67895           0.98685           0.91654
```

The data set metrics provide a high-level overview of network performance. To see the impact each class has on the overall performance, inspect the metrics for each class using the `metrics.ClassMetrics` property.

`metrics.ClassMetrics`

```
ans=3x3 table
           Accuracy   IoU   MeanBFScore
           _____   _____   _____
background   0.99466   0.99212   0.98529
car           0.75977   0.50096   0.82682
truck        0.75814   0.54378   0.77119
```

Although the network overall performance is good, the class metrics show that biased classes (car and truck) are not segmented as well as the classes with abundant data (background). You can improve the network performance by training the network on more labeled data containing the car and truck classes.

## Supporting Functions

### Function to Augment Data

The `augmentData` function randomly flips the 2-D spherical image and associated labels in the horizontal direction.

```
function out = augmentData(inp)
%augmentData Apply random horizontal flipping.

out = cell(size(inp));

% Randomly flip the five-channel image and pixel labels horizontally.
I = inp{1};
sz = size(I);
tform = randomAffine2d('XReflection',true);
rout = affineOutputView(sz,tform,'BoundsStyle','centerOutput');

out{1} = imwarp(I,tform,'OutputView',rout);
out{2} = imwarp(inp{2},tform,'OutputView',rout);
end
```

### Function to Display Lidar Segmentation Map Overlaid on 2-D Spherical Image

The `helperDisplayLidarOverlayImage` function overlays the semantic segmentation map over the intensity channel of the 2-D spherical image. The function also resizes the overlaid image for better visualization.

```
function helperDisplayLidarOverlayImage(lidarImage, labelMap, classNames)
%helperDisplayLidarOverlayImage Overlay labels over the intensity image.
%
% helperDisplayLidarOverlayImage(lidarImage, labelMap, classNames)
% displays the overlaid image. lidarImage is a five-channel lidar input.
% labelMap contains pixel labels and classNames is an array of label
% names.

% Read the intensity channel from the lidar image.
intensityChannel = uint8(lidarImage(:,:,4));

% Load the lidar color map.
cmap = helperLidarColorMap();

% Overlay the labels over the intensity image.
B = labeloverlay(intensityChannel,labelMap,'Colormap',cmap,'Transparency',0.4);

% Resize for better visualization.
B = imresize(B, 'Scale', [3 1], 'method', 'nearest');
imshow(B);

% Display the color bar.
helperPixelLabelColorbar(cmap, classNames);
end
```

### Function To Display Lidar Segmentation Map Overlaid on 3-D Point Cloud

The `helperDisplayLidarOverPointCloud` function overlays the segmentation result over a 3-D organized point cloud.

```
function helperDisplayLidarOverlayPointCloud(ptCloud, labelMap, numClasses)
%helperDisplayLidarOverlayPointCloud Overlay labels over a point cloud object.
%
% helperDisplayLidarOverlayPointCloud(ptCloud, labelMap, numClasses)
% displays the overlaid pointCloud object. ptCloud is the organized
% 3-D point cloud input. labelMap contains pixel labels and numClasses
% is the number of predicted classes.

sz = size(labelMap);

% Apply the color red to cars.
carClassCar = zeros(sz(1), sz(2), numClasses, 'uint8');
carClassCar(:,:,1) = 255*ones(sz(1), sz(2), 'uint8');

% Apply the color blue to trucks.
truckClassColor = zeros(sz(1), sz(2), numClasses, 'uint8');
truckClassColor(:,:,3) = 255*ones(sz(1), sz(2), 'uint8');

% Apply the color gray to the background.
backgroundClassColor = 153*ones(sz(1), sz(2), numClasses, 'uint8');

% Extract indices from the labels.
```

```

carIndices = labelMap == 'car';
truckIndices = labelMap == 'truck';
backgroundIndices = labelMap == 'background';

% Extract a point cloud for each class.
carPointCloud = select(ptCloud, carIndices, 'OutputSize','full');
truckPointCloud = select(ptCloud, truckIndices, 'OutputSize','full');
backgroundPointCloud = select(ptCloud, backgroundIndices, 'OutputSize','full');

% Apply colors to different classes.
carPointCloud.Color = carClassColor;
truckPointCloud.Color = truckClassColor;
backgroundPointCloud.Color = backgroundClassColor;

% Merge and add all the processed point clouds with class information.
coloredCloud = pcmerge(carPointCloud, truckPointCloud, 0.01);
coloredCloud = pcmerge(coloredCloud, backgroundPointCloud, 0.01);

% Plot the colored point cloud. Set an ROI for better visualization.
ax = pcshow(coloredCloud);
set(ax, 'XLim', [-35.0 35.0], 'YLim', [-32.0 32.0], 'ZLim', [-3 8], ...
    'XColor', 'none', 'YColor', 'none', 'ZColor', 'none');
set(get(ax, 'parent'), 'units', 'normalized');
end

```

### Function to Define Lidar Colormap

The helperLidarColorMap function defines the colormap used by the lidar data set.

```

function cmap = helperLidarColorMap()

cmap = [
    0.00 0.00 0.00 % background
    0.98 0.00 0.00 % car
    0.00 0.00 0.98 % truck
];
end

```

### Function to Display Pixel Label Colorbar

The helperPixelLabelColorbar function adds a colorbar to the current axis. The colorbar is formatted to display the class names with the color.

```

function helperPixelLabelColorbar(cmap, classNames)

colormap(gca, cmap);

% Add a colorbar to the current figure.
c = colorbar('peer', gca);

% Use class names for tick marks.
c.TickLabels = classNames;
numClasses = size(classNames, 1);

% Center tick labels.
c.Ticks = 1/(numClasses * 2):1/numClasses:1;

% Remove tick marks.

```

```
c.TickLength = 0;  
end
```

### **References**

[1] Wang, Yuan, Tianyue Shi, Peng Yun, Lei Tai, and Ming Liu. "PointSeg: Real-Time Semantic Segmentation Based on 3D LiDAR Point Cloud." *ArXiv:1807.06288 [Cs]*, September 25, 2018. <http://arxiv.org/abs/1807.06288>.

## Detect, Classify, and Track Vehicles Using Lidar

This example shows how to detect, classify, and track vehicles by using lidar point cloud data captured by a lidar sensor mounted on an ego vehicle. The lidar data used in this example is recorded from a highway-driving scenario. In this example, the point cloud data is segmented to determine the class of objects using the `PointSeg` network. A joint probabilistic data association (JPDA) tracker with an interactive multiple model filter is used to track the detected vehicles.

### Overview

The perception module plays an important role in achieving full autonomy for vehicles with an ADAS system. Lidar and camera are essential sensors in the perception workflow. Lidar is good at extracting accurate depth information of objects, while camera produces rich and detailed information of the environment which is useful for object classification.

This example mainly includes these parts:

- Ground plane segmentation
- Semantic segmentation
- Oriented bounding box fitting
- Tracking oriented bounding boxes

The flowchart gives an overview of the whole system.

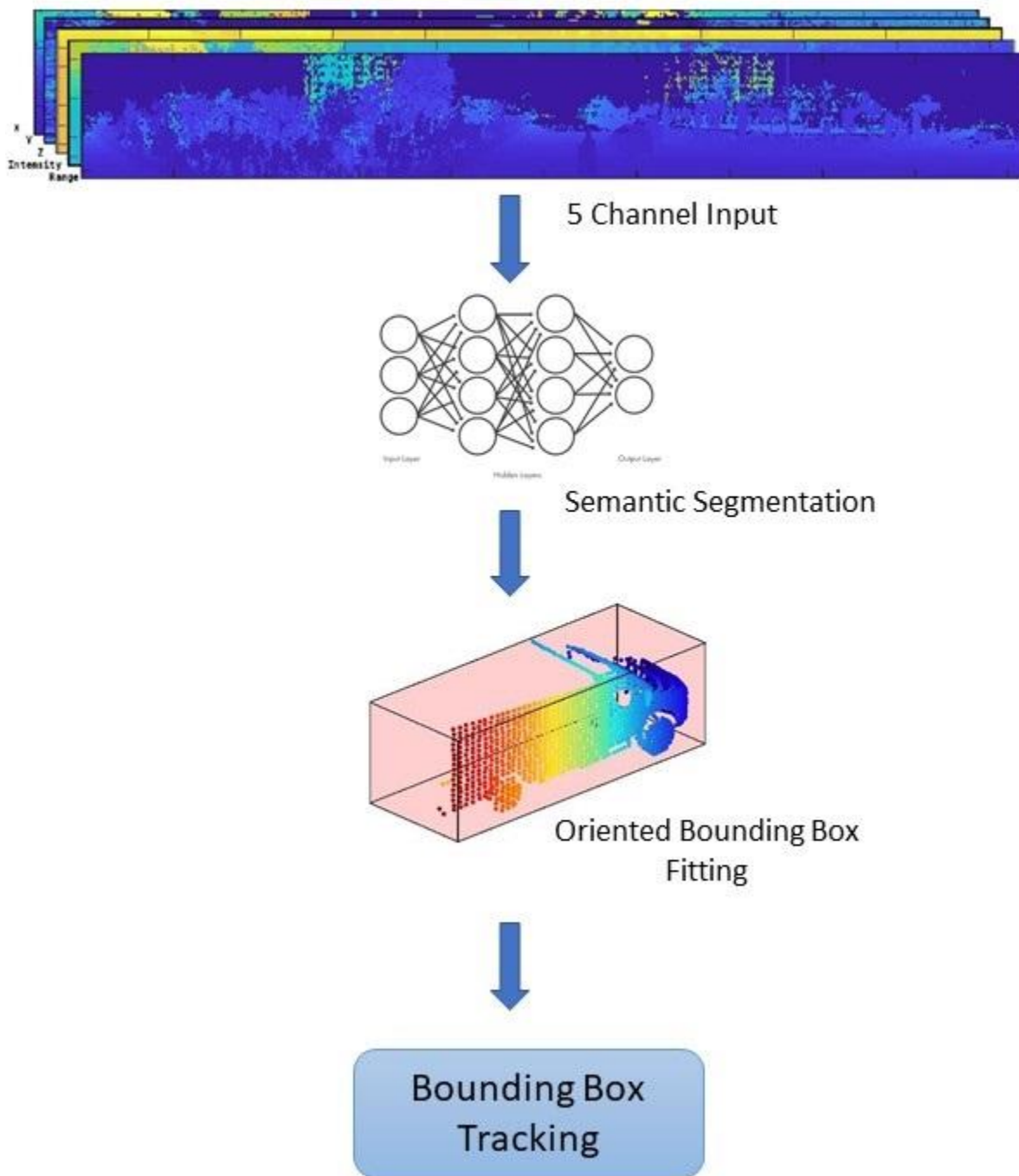

### Load Data

The lidar sensor generates point cloud data either in an organized format or an unorganized format. The data used in this example is collected using an Ouster OS1 lidar sensor. This lidar produces an organized point cloud with 64 horizontal scan lines. The point cloud data is comprised of three channels, representing the  $x$ -,  $y$ -, and  $z$ -coordinates of the points. Each channel is of the size 64-by-1024. Use the helper function `helperDownloadData` to download the data and load them into the MATLAB® workspace.

**Note:** This download can take a few minutes.

```
[ptClouds,pretrainedModel] = helperDownloadData;
```

### Ground Plane Segmentation

This example employs a hybrid approach that uses the `segmentGroundFromLidarData` and `pcfitplane` functions. First, estimate the ground plane parameters using the `segmentGroundFromLidarData` function. The estimated ground plane is divided into strips along the direction of the vehicle in order to fit the plane, using the `pcfitplane` function on each strip. This hybrid approach robustly fits the ground plane in a piecewise manner and handles variations in the point cloud.

```
% Load point cloud
ptCloud = ptClouds{1};
% Define ROI for cropping point cloud
xLimit = [-30,30];
yLimit = [-12,12];
zLimit = [-3,15];

roi = [xLimit,yLimit,zLimit];
% Extract ground plane
[nonGround,ground] = helperExtractGround(ptCloud,roi);
figure;
pcshowpair(nonGround,ground);
legend({'\color{white} Nonground', '\color{white} Ground'}, 'Location', 'northeastoutside');
```

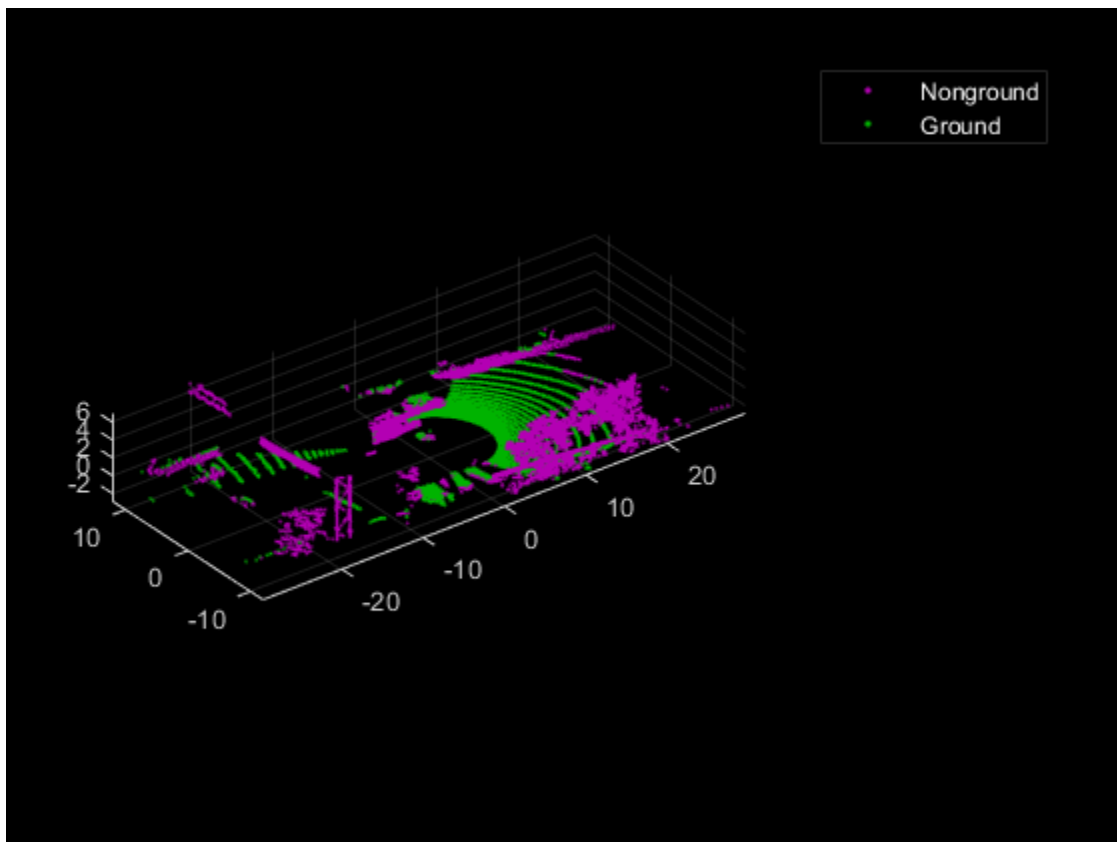

## Semantic Segmentation

This example uses a pretrained `PointSeg` network model. `PointSeg` is an end-to-end real-time semantic segmentation network trained for object classes like cars, trucks, and background. The output from the network is a masked image with each pixel labeled per its class. This mask is used to filter different types of objects in the point cloud. The input to the network is five-channel image, that is  $x$ ,  $y$ ,  $z$ , *intensity*, and *range*. For more information on the network or how to train the network, refer to the “Lidar Point Cloud Semantic Segmentation Using PointSeg Deep Learning Network” on page 1-128 example.

### Prepare Input Data

The `helperPrepareData` function generates five-channel data from the loaded point cloud data.

```
% Load and visualize a sample frame
frame = helperPrepareData(ptCloud);
figure;
subplot(5,1,1);
imagesc(frame(:,:,1));
title('X channel');

subplot(5,1,2);
imagesc(frame(:,:,2));
title('Y channel');

subplot(5,1,3);
imagesc(frame(:,:,3));
title('Z channel');

subplot(5,1,4);
imagesc(frame(:,:,4));
title('Intensity channel');

subplot(5,1,5);
imagesc(frame(:,:,5));
title('Range channel');
```



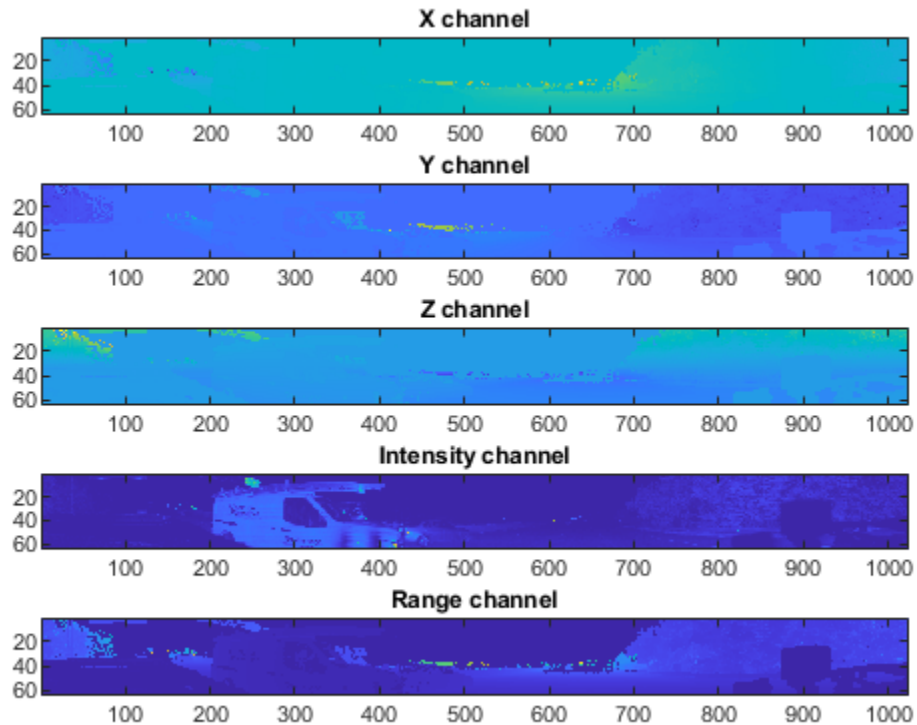

Run forward inference on one frame from the loaded pre-trained network.

```

if ~exist('net','var')
    net = pretrainedModel.net;
end

% Define classes
classes = ["background", "car", "truck"];

% Define color map
lidarColorMap = [
    0.98  0.98  0.00 % unknown
    0.01  0.98  0.01 % green color for car
    0.01  0.01  0.98 % blue color for motorcycle
];

% Run forward pass
pxdsResults = semanticseg(frame,net);

% Overlay intensity image with segmented output
segmentedImage = labeloverlay(uint8(frame(:,:,4)),pxdsResults,'Colormap',lidarColorMap,'Transparent');

% Display results
figure;
imshow(segmentedImage);
helperPixelLabelColorbar(lidarColorMap,classes);

```



Use the generated semantic mask to filter point clouds containing trucks. Similarly, filter point clouds for other classes.

```
truckIndices = pxdsResults == 'truck';
truckPointCloud = select(nonGround, truckIndices, 'OutputSize', 'full');

% Crop point cloud for better display
croppedPtCloud = select(ptCloud, findPointsInROI(ptCloud, roi));
croppedTruckPtCloud = select(truckPointCloud, findPointsInROI(truckPointCloud, roi));

% Display ground and nonground points
figure;
pcshowpair(croppedPtCloud, croppedTruckPtCloud);
legend({'\color{white} Nonvehicle', '\color{white} Vehicle'}, 'Location', 'northeastoutside');
```

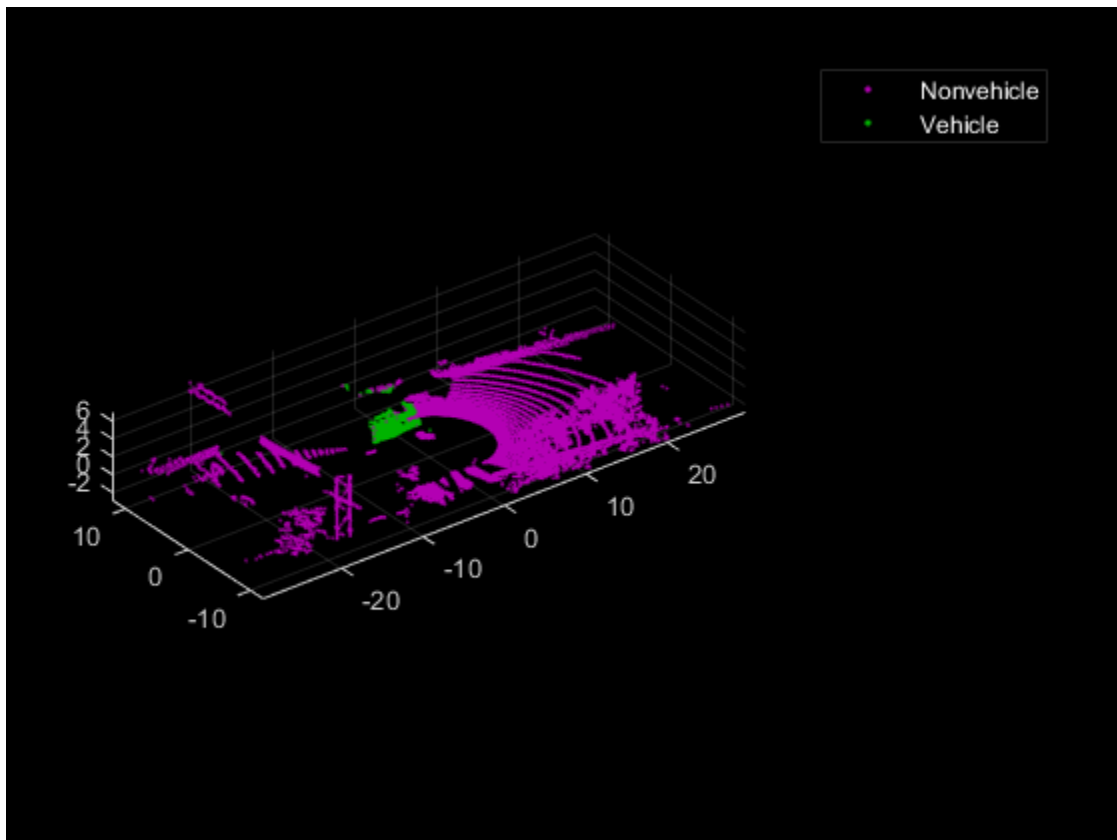

### Clustering and Bounding Box Fitting

After extracting point clouds of different object classes, the objects are clustered by applying Euclidean clustering using the `pcsegdist` function. To group all the points belonging to one single cluster, the point cloud obtained as a cluster is used as seed points for growing region in nonground

points. Use the `findNearestNeighbors` function to loop over all the points to grow the region. The extracted cluster is fitted in an L-shape bounding box using the `pcfitcuboid` function. These clusters of vehicles resemble the shape of the letter L when seen from a top-down view. This feature helps in estimating the orientation of the vehicle. The oriented bounding box fitting helps in estimating the heading angle of the objects, which is useful in applications such as path planning and traffic maneuvering.

The cuboid boundaries of the clusters can also be calculated by finding the minimum and maximum spatial extents in each direction. However, this method fails in estimating the orientation of the detected vehicles. The difference between the two methods is shown in the figure.

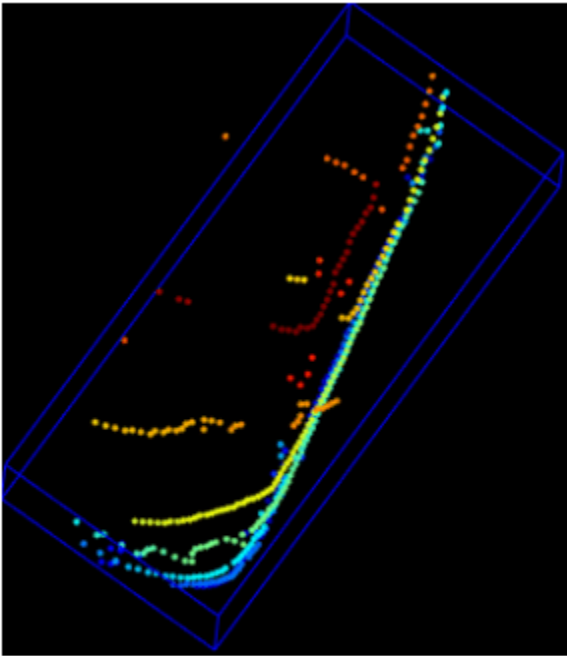

### Min. Area Rectangle

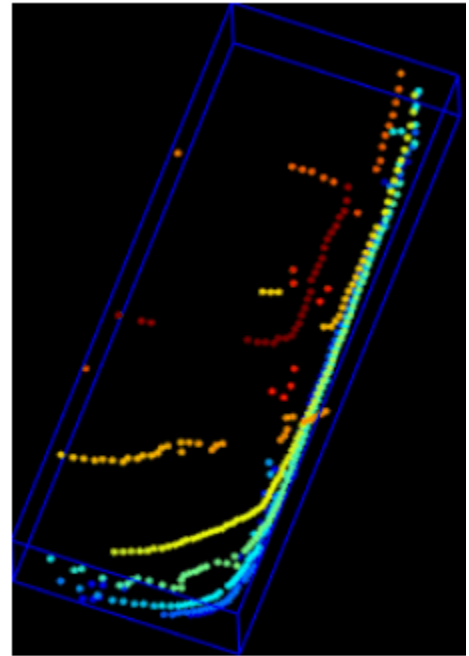

### L-Shape Fitting

```
[labels,numClusters] = pcsegdist(croppedTruckPtCloud,1);

% Define cuboid parameters
params = zeros(0,9);

for clusterIndex = 1:numClusters
    ptsInCluster = labels == clusterIndex;

    pc = select(croppedTruckPtCloud,ptsInCluster);
    location = pc.Location;

    xl = (max(location(:,1)) - min(location(:,1)));
    yl = (max(location(:,2)) - min(location(:,2)));
    zl = (max(location(:,3)) - min(location(:,3)));

    % Filter small bounding boxes
    if size(location,1)*size(location,2) > 20 && any(any(pc.Location)) && xl > 1 && yl > 1
        indices = zeros(0,1);
    end
end
```

```
objectPtCloud = pointCloud(location);
for i = 1:size(location,1)
    seedPoint = location(i,:);
    indices(end+1) = findNearestNeighbors(nonGround,seedPoint,1);
end

% Remove overlapping indices
indices = unique(indices);

% Fit oriented bounding box
model = pcfiteboid(select(nonGround,indices));
params(end+1,:) = model.Parameters;
end
end

% Display point cloud and detected bounding box
figure;
pcshow(croppedPtCloud.Location,croppedPtCloud.Location(:,3));
showShape('cuboid',params,"Color","red","Label","Truck");
```

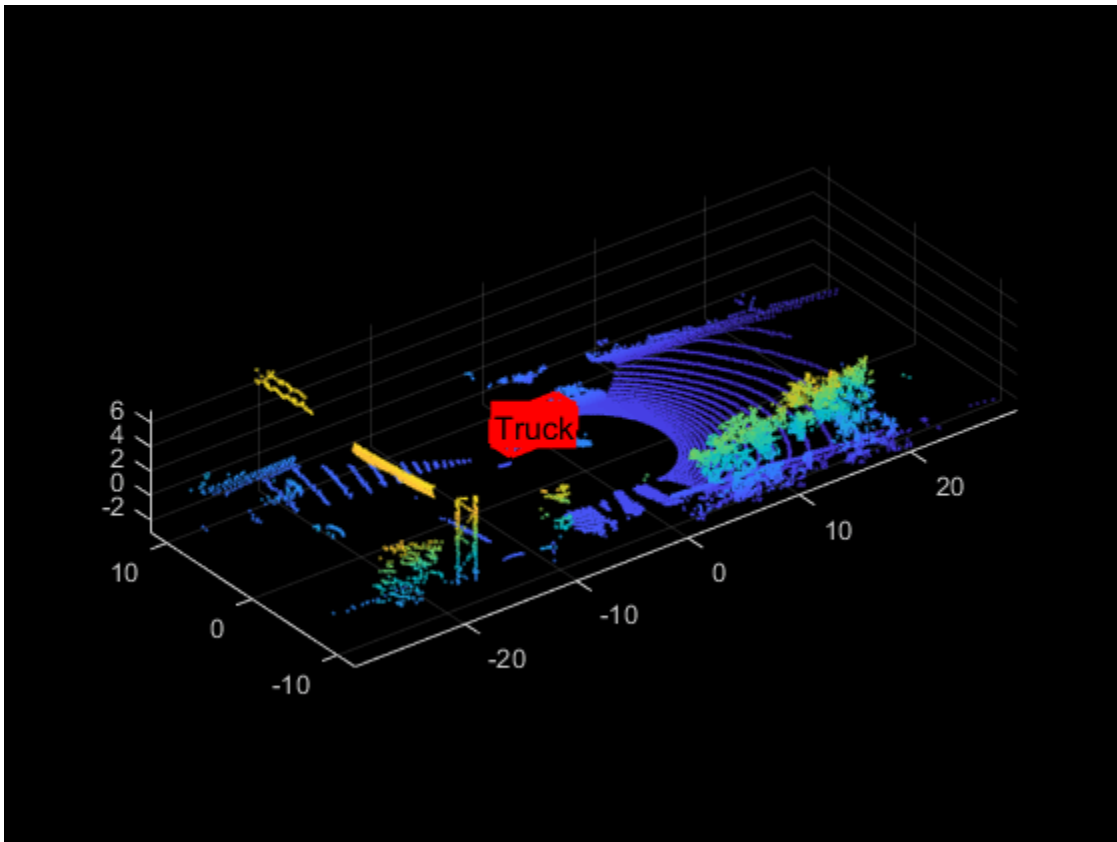

### Visualization Setup

Use the `helperLidarObjectDetectionDisplay` class to visualize the complete workflow in one window. The layout of the visualization window is divided into the following sections:

- 1 Lidar Range Image: point cloud image in 2-D as a range image

- 2 Segmented Image: Detected labels generated from the semantic segmentation network overlaid with the intensity image or the fourth channel of the data
- 3 Oriented Bounding Box Detection: 3-D point cloud with oriented bounding boxes
- 4 Top View: Top view of the point cloud with oriented bounding boxes

```
display = helperLidarObjectDetectionDisplay;
```

### Loop Through Data

The `helperLidarObjectDetection` class is a wrapper encapsulating all the segmentation, clustering, and bounding box fitting steps mentioned in the above sections. Use the `findDetections` function to extract the detected objects.

```
% Initialize lidar object detector
lidarDetector = helperLidarObjecDetector('Model',net,'XLimits',xLimit,...
    'YLimit',yLimit,'ZLimit',zLimit);

% Prepare 5-D lidar data
inputData = helperPrepareData(ptClouds);

% Set random number generator for reproducible results
S = rng(2018);

% Initialize the display
initializeDisplay(display);

numFrames = numel(inputData);
for count = 1:numFrames

    % Get current data
    input = inputData{count};

    rangeImage = input(:,:,5);

    % Extact bounding boxes from lidar data
    [boundingBox,coloredPtCloud,pointLabels] = detectBbox(lidarDetector,input);

    % Update display with colored point cloud
    updatePointCloud(display,coloredPtCloud);

    % Update bounding boxes
    updateBoundingBox(display,boundingBox);

    % Update segmented image
    updateSegmentedImage(display,pointLabels,rangeImage);

    drawnow('limitrate');
end
```

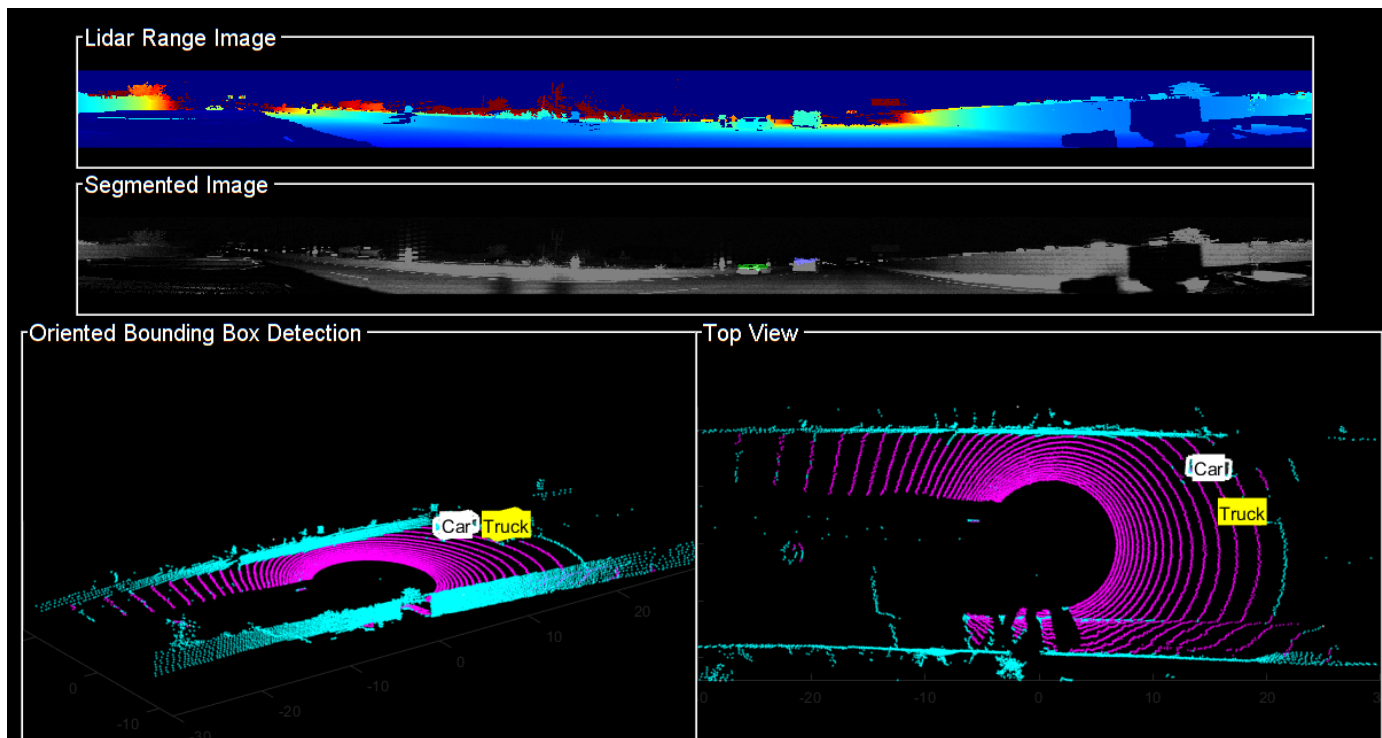

### Tracking Oriented Bounding Boxes

In this example, you use a joint probabilistic data association (JPDA) tracker. The time step  $dt$  is set to 0.1 seconds since the dataset is captured at 10 Hz. The state-space model used in the tracker is based on a cuboid model with parameters,  $[x, y, z, \phi, l, w, h]$ . For more details on how to track bounding boxes in lidar data, see the “Track Vehicles Using Lidar: From Point Cloud to Track List” (Sensor Fusion and Tracking Toolbox) example. In this example, the class information is provided using the `ObjectAttributes` property of the `objectDetection` object. When creating new tracks, the filter initialization function, defined using the helper function `helperMultiClassInitIMMFilter` uses the class of the detection to set up initial dimensions of the object. This helps the tracker to adjust bounding box measurement model with the appropriate dimensions of the track.

Set up a JPDA tracker object with these parameters.

```
assignmentGate = [10 100]; % Assignment threshold;
confThreshold = [7 10];   % Confirmation threshold for history logic
delThreshold = [2 3];    % Deletion threshold for history logic
Kc = 1e-5;               % False-alarm rate per unit volume

% IMM filter initialization function
filterInitFcn = @helperMultiClassInitIMMFilter;

% A joint probabilistic data association tracker with IMM filter
tracker = trackerJPDA('FilterInitializationFcn',filterInitFcn,...
    'TrackLogic','History',...
    'AssignmentThreshold',assignmentGate,...
    'ClutterDensity',Kc,...
    'ConfirmationThreshold',confThreshold,...
    'DeletionThreshold',delThreshold,'InitializationThreshold',0);
```

```

allTracks = struct([]);
time = 0;
dt = 0.1;

```

```

% Define Measurement Noise
measNoise = blkdiag(0.25*eye(3),25,eye(3));

```

```

numTracks = zeros(numFrames,2);

```

The detected objects are assembled as a cell array of `objectDetection` (Automated Driving Toolbox) objects using the `helperAssembleDetections` function.

```

display = helperLidarObjectDetectionDisplay;
initializeDisplay(display);

```

```

for count = 1:numFrames
    time = time + dt;
    % Get current data
    input = inputData{count};

    rangeImage = input(:,:,5);

    % Extract bounding boxes from lidar data
    [boundingBox,coloredPtCloud,pointLabels] = detectBbox(lidarDetector,input);

    % Assemble bounding boxes into objectDetections
    detections = helperAssembleDetections(boundingBox,measNoise,time);

    % Pass detections to tracker
    if ~isempty(detections)
        % Update the tracker
        [confirmedTracks,tentativeTracks,allTracks,info] = tracker(detections,time);
        numTracks(count,1) = numel(confirmedTracks);
    end

    % Update display with colored point cloud
    updatePointCloud(display,coloredPtCloud);

    % Update segmented image
    updateSegmentedImage(display,pointLabels,rangeImage);

    % Update the display if the tracks are not empty
    if ~isempty(confirmedTracks)
        updateTracks(display,confirmedTracks);
    end

    drawnow('limitrate');
end

```

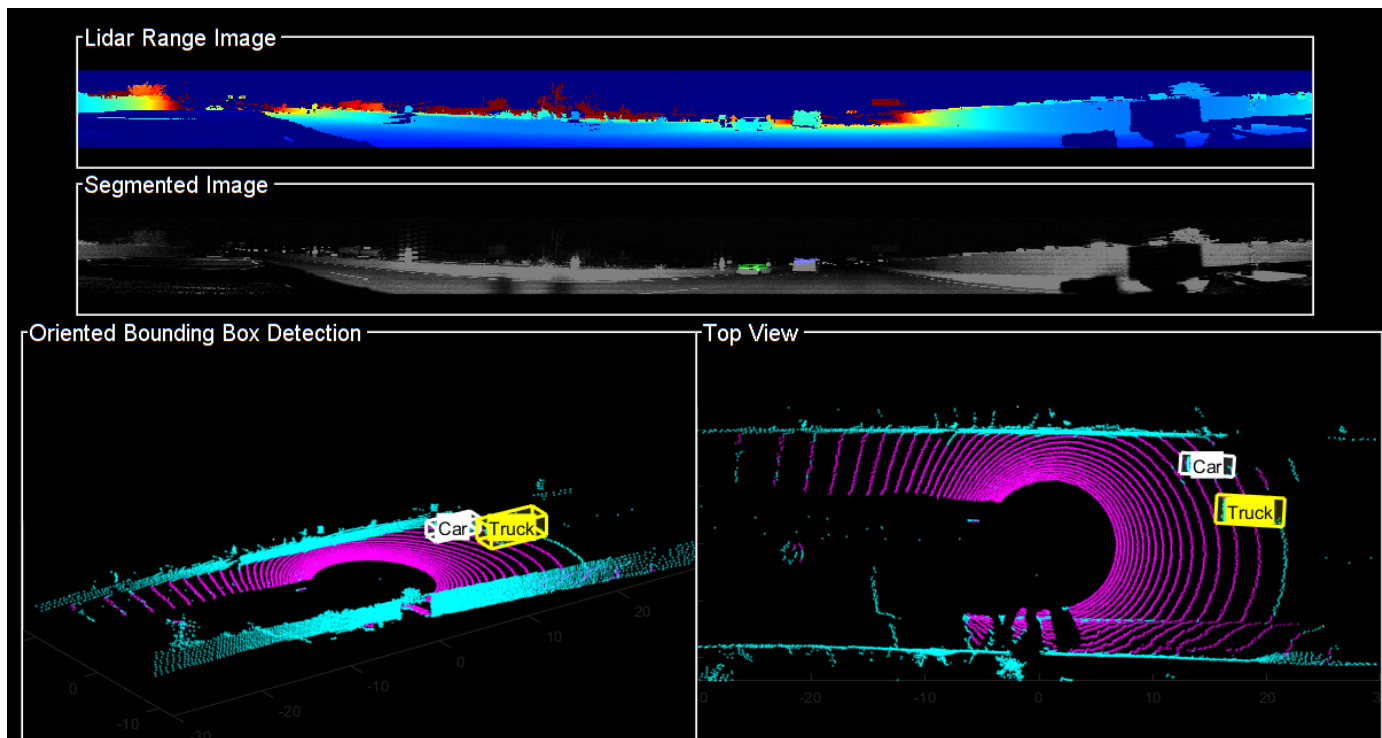

## Summary

This example showed how to detect and classify vehicles fitted with oriented bounding box on lidar data. You also learned how to use IMM filter to track objects with multiple class information. The semantic segmentation results can be improved further by adding more training data.

## Supporting Functions

### helperPrepareData

```
function multiChannelData = helperPrepareData(input)
% Create 5-channel data as x, y, z, intensity and range
% of size 64-by-1024-by-5 from pointCloud.

if isa(input, 'cell')
    numFrames = numel(input);
    multiChannelData = cell(1, numFrames);
    for i = 1:numFrames
        inputData = input{i};

        x = inputData.Location(:,:,1);
        y = inputData.Location(:,:,2);
        z = inputData.Location(:,:,3);

        intensity = inputData.Intensity;
        range = sqrt(x.^2 + y.^2 + z.^2);

        multiChannelData{i} = cat(3, x, y, z, intensity, range);
    end
else
    x = input.Location(:,:,1);
```



```

    y = input.Location(:,:,2);
    z = input.Location(:,:,3);

    intensity = input.Intensity;
    range = sqrt(x.^2 + y.^2 + z.^2);

    multiChannelData = cat(3, x, y, z, intensity, range);
end
end

```

### pixelLabelColorbar

```

function helperPixelLabelColorbar(cmap, classNames)
% Add a colorbar to the current axis. The colorbar is formatted
% to display the class names with the color.

colormap(gca,cmap)

% Add colorbar to current figure.
c = colorbar('peer', gca);

% Use class names for tick marks.
c.TickLabels = classNames;
numClasses = size(cmap,1);

% Center tick labels.
c.Ticks = 1/(numClasses*2):1/numClasses:1;

% Remove tick mark.
c.TickLength = 0;
end

```

### helperExtractGround

```

function [ptCloudNonGround,ptCloudGround] = helperExtractGround(ptCloudIn, roi)
% Crop the point cloud

idx = findPointsInROI(ptCloudIn,roi);
pc = select(ptCloudIn,idx,'OutputSize','full');

% Get the ground plane the indices using piecewise plane fitting
[ptCloudGround,idx] = piecewisePlaneFitting(pc,roi);

nonGroundIdx = true(size(pc.Location,[1,2]));
nonGroundIdx(idx) = false;
ptCloudNonGround = select(pc,nonGroundIdx,'OutputSize','full');
end

function [groundPlane,idx] = piecewisePlaneFitting(ptCloudIn,roi)
groundPtsIdx = ...
    segmentGroundFromLidarData(ptCloudIn, ...
    'ElevationAngleDelta',5,'InitialElevationAngle',15);
groundPC = select(ptCloudIn,groundPtsIdx,'OutputSize','full');

% Divide x-axis in 3 regions
segmentLength = (roi(2) - roi(1))/3;

```

```
x1 = [roi(1),roi(1) + segmentLength];
x2 = [x1(2),x1(2) + segmentLength];
x3 = [x2(2),x2(2) + segmentLength];

roi1 = [x1,roi(3:end)];
roi2 = [x2,roi(3:end)];
roi3 = [x3,roi(3:end)];

idxBack = findPointsInROI(groundPC,roi1);
idxCenter = findPointsInROI(groundPC,roi2);
idxForward = findPointsInROI(groundPC,roi3);

% Break the point clouds in front and back
ptBack = select(groundPC,idxBack,'OutputSize','full');

ptForward = select(groundPC,idxForward,'OutputSize','full');

[~,inliersForward] = planeFit(ptForward);
[~,inliersBack] = planeFit(ptBack);
idx = [inliersForward; idxCenter; inliersBack];
groundPlane = select(ptCloudIn, idx,'OutputSize','full');
end

function [plane,inlinersIdx] = planeFit(ptCloudIn)
[~,inlinersIdx, ~] = pcfitplane(ptCloudIn,1,[0, 0, 1]);
plane = select(ptCloudIn,inlinersIdx,'OutputSize','full');
end
```

### helperAssembleDetections

```
function mydetections = helperAssembleDetections(bboxes,measNoise,timestamp)
% Assemble bounding boxes as cell array of objectDetection

mydetections = cell(size(bboxes,1),1);
for i = 1:size(bboxes,1)
    classid = bboxes(i,end);
    lidarModel = [bboxes(i,1:3), bboxes(i,end-1), bboxes(i,4:6)];
    % To avoid direct confirmation by the tracker, the ClassID is passed as
    % ObjectAttributes.
    mydetections{i} = objectDetection(timestamp, ...
        lidarModel,'MeasurementNoise',...
        measNoise,'ObjectAttributes',struct('ClassID',classid));
end
end
```

### helperDownloadData

```
function [lidarData, pretrainedModel] = helperDownloadData
outputFolder = fullfile(tempdir,'WPI');
url = 'https://ssd.mathworks.com/supportfiles/lidar/data/lidarSegmentationAndTrackingData.tar.gz';
lidarDataTarFile = fullfile(outputFolder,'lidarSegmentationAndTrackingData.tar.gz');
if ~exist(lidarDataTarFile,'file')
    mkdir(outputFolder);
    websave(lidarDataTarFile,url);
    untar(lidarDataTarFile,outputFolder);
end
% Check if tar.gz file is downloaded, but not uncompressed
if ~exist(fullfile(outputFolder,'WPI_LidarData.mat'),'file')
```

```
    untar(lidarDataTarFile,outputFolder);
end
% Load lidar data
data = load(fullfile(outputFolder,'highwayData.mat'));
lidarData = data.ptCloudData;

% Download pretrained model
url = 'https://ssd.mathworks.com/supportfiles/lidar/data/pretrainedPointSegModel.mat';
modelFile = fullfile(outputFolder,'pretrainedPointSegModel.mat');
if ~exist(modelFile,'file')
    websave(modelFile,url);
end
pretrainedModel = load(fullfile(outputFolder,'pretrainedPointSegModel.mat'));
end
```

## References

- [1] Xiao Zhang, Wenda Xu, Chiyu Dong and John M. Dolan, "Efficient L-Shape Fitting for Vehicle Detection Using Laser Scanners", IEEE Intelligent Vehicles Symposium, June 2017
- [2] Y. Wang, T. Shi, P. Yun, L. Tai, and M. Liu, "Pointseg: Real-time semantic segmentation based on 3d lidar point cloud," arXiv preprint arXiv:1807.06288, 2018.

## Feature-Based Map Building from Lidar Data

This example demonstrates how to process 3-D lidar data from a sensor mounted on a vehicle to progressively build a map. Such a map is suitable for automated driving workflows such as localization and navigation. These maps can be used to localize a vehicle within a few centimeters.

### Overview

There are different ways to register point clouds. The typical approach is to use the complete point cloud for registration. “Build a Map from Lidar Data” (Automated Driving Toolbox) example uses this approach for map building. This example uses distinctive features extracted from the point cloud for map building.

In this example, you will learn how to:

- Load and visualize recorded driving data.
- Build a map using lidar scans.

### Load Recorded Driving Data

The data used in this example represents approximately 100 seconds of lidar, GPS, and IMU data. The data is saved in separate MAT-files as `timetable` objects. Download the lidar data MAT file from the repository and load it into the MATLAB® workspace.

**Note:** This download can take a few minutes.

```
baseDownloadURL = ['https://github.com/mathworks/udacity-self-driving-data' ...
                  '-subset/raw/master/drive_segment_11_18_16/'];
dataFolder      = fullfile(tempdir, 'drive_segment_11_18_16', filesep);
options         = weboptions('Timeout', Inf);

lidarFileName = dataFolder+"lidarPointClouds.mat";

% Check whether the folder and data file already exist or not
folderExists = exist(dataFolder, 'dir');
matfilesExist = exist(lidarFileName, 'file');

% Create a new folder if it does not exist
if ~folderExists
    mkdir(dataFolder);
end

% Download the lidar data if it does not exist
if ~matfilesExist
    disp('Downloading lidarPointClouds.mat (613 MB)...');
    websave(lidarFileName, baseDownloadURL+"lidarPointClouds.mat", options);
end
```

Load the point cloud data saved from a Velodyne® HDL32E lidar sensor. Each lidar scan is stored as a 3-D point cloud using the `pointCloud` object. This object internally organizes the data using a Kd-tree data structure for faster search. The timestamp associated with each lidar scan is recorded in the `Time` variable of the `timetable` object.

```
% Load lidar data from MAT-file
data = load(lidarFileName);
lidarPointClouds = data.lidarPointClouds;
```

```
% Display first few rows of lidar data
head(lidarPointClouds)
```

```
ans=8x1 timetable
      Time      PointCloud
-----
23:46:10.5115  1x1 pointCloud
23:46:10.6115  1x1 pointCloud
23:46:10.7116  1x1 pointCloud
23:46:10.8117  1x1 pointCloud
23:46:10.9118  1x1 pointCloud
23:46:11.0119  1x1 pointCloud
23:46:11.1120  1x1 pointCloud
23:46:11.2120  1x1 pointCloud
```

### Visualize Driving Data

To understand what the scene contains, visualize the recorded lidar data using the `pcplayer` object.

```
% Specify limits for the player
xlims = [-45 45]; % meters
ylims = [-45 45];
zlims = [-10 20];

% Create a pcplayer to visualize streaming point clouds from lidar sensor
lidarPlayer = pcplayer(xlims,ylims,zlims);

% Customize player axes labels
xlabel(lidarPlayer.Axes,'X (m)');
ylabel(lidarPlayer.Axes,'Y (m)');
zlabel(lidarPlayer.Axes,'Z (m)');
title(lidarPlayer.Axes,'Lidar Sensor Data');

% Loop over and visualize the data
for l = 1:height(lidarPointClouds)

    % Extract point cloud
    ptCloud = lidarPointClouds.PointCloud(l);

    % Update lidar display
    view(lidarPlayer,ptCloud);
end
```

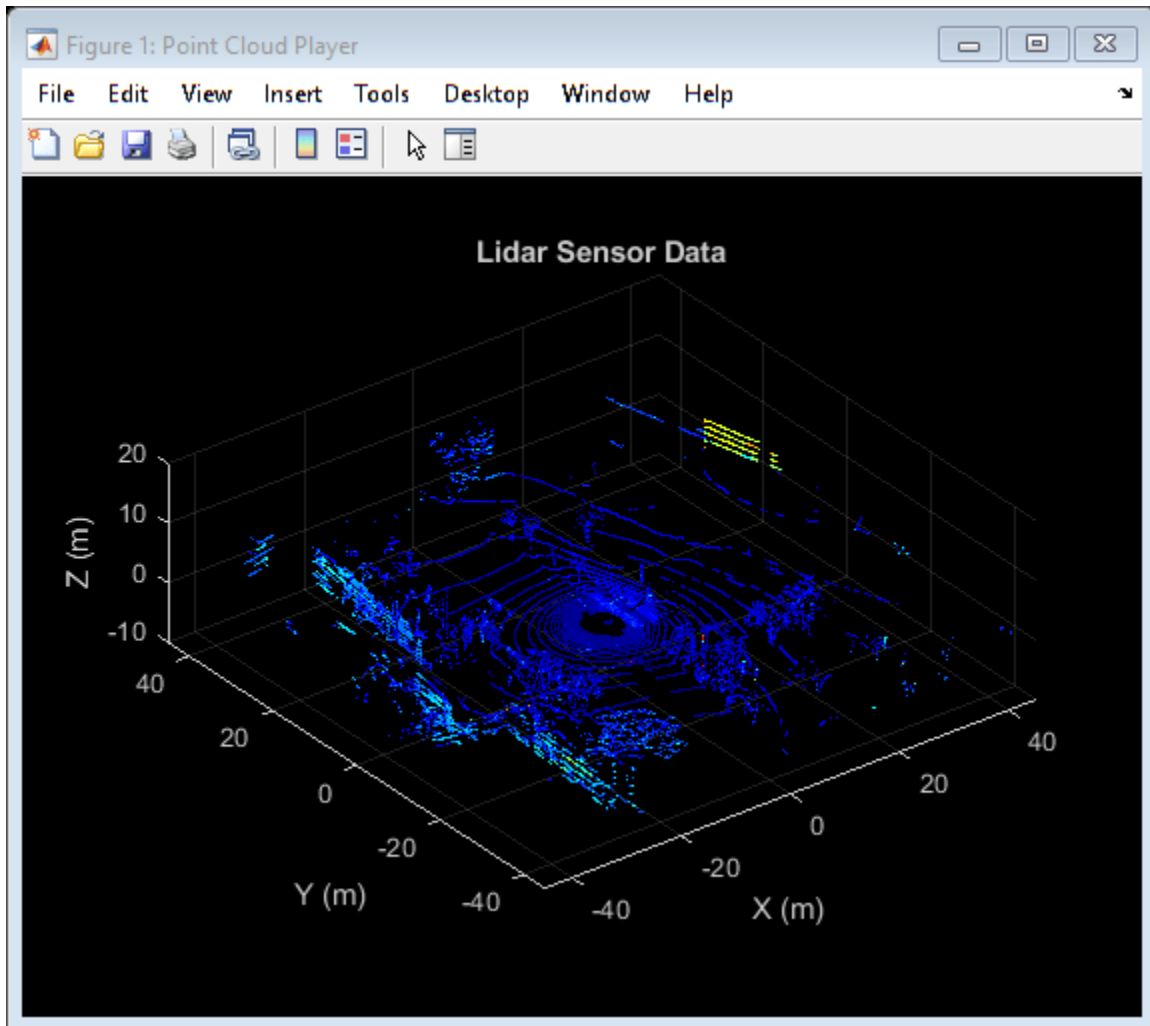

### Use Recorded Lidar Data to Build Map

Lidars can be used to build centimeter-accurate maps which can later be used for in-vehicle localization. A typical approach to build such a map is to align successive lidar scans obtained from a moving vehicle and combine them into a single, large point cloud. The rest of this example explores this approach.

#### Preprocessing

Take two point clouds corresponding to nearby lidar scans. Every tenth scan is used to speed up processing and accumulate enough motion between scans.

```
rng('default');
skipFrames = 10;
frameNum   = 100;
```

```
fixed = lidarPointClouds.PointCloud(frameNum);
moving = lidarPointClouds.PointCloud(frameNum+skipFrames);
```

Process the point cloud to retain structures in the point cloud that are distinctive. These steps are executed using the `helperProcessPointCloud` function:

- Detect and remove the ground plane.
- Detect and remove ego vehicle.

These steps are described in more detail in the “Ground Plane and Obstacle Detection Using Lidar” (Automated Driving Toolbox) example.

```
fixedProcessed = helperProcessPointCloud(fixed);
movingProcessed = helperProcessPointCloud(moving);
```

Display the initial and processed point clouds in top-view. Magenta points correspond to the ground plane and ego vehicle.

```
hFigFixed = figure;
axFixed = axes('Parent',hFigFixed,'Color',[0 0 0]);

pcshowpair(fixed,fixedProcessed,'Parent',axFixed);
title(axFixed,'Segmented Ground and Ego Vehicle');
view(axFixed,2);
```

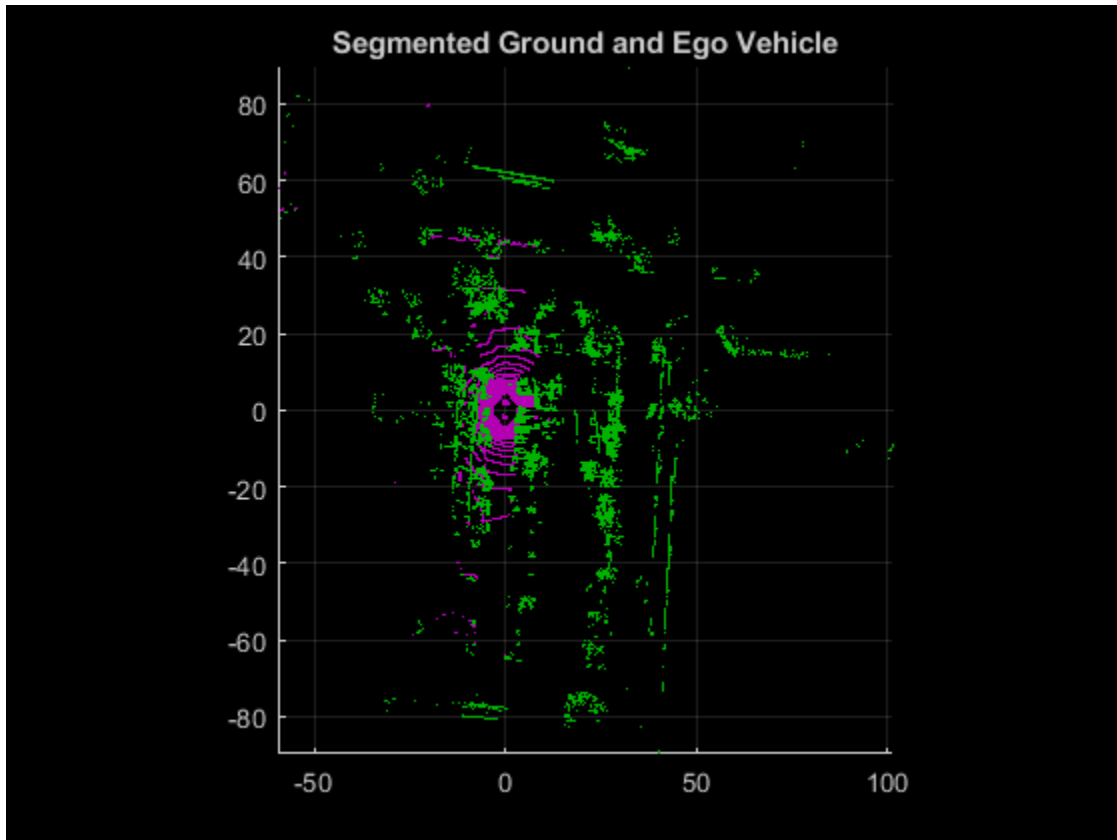

Downsample the point clouds to improve registration accuracy and algorithm speed.

```
gridStep = 0.5;
fixedDownsampled = pcdsample(fixedProcessed,"gridAverage",gridStep);
movingDownsampled = pcdsample(movingProcessed,"gridAverage",gridStep);
```

### Feature-Based Registration

Align and combine successive lidar scans using feature-based registration as follows:

- Extract Fast Point Feature Histogram (FPFH) descriptors from each scan using the `extractFPFHFeatures` function.
- Identify point correspondences by comparing the descriptors using the `pcmatchfeatures` function.
- Estimate the rigid transformation from point correspondences using the `estimateGeometricTransform3D` function.
- Align and merge the point cloud with respect to reference point cloud using the estimated transformation. This is performed using the `pcalign` function.

```
% Extract FPFH Features for each point cloud
neighbors = 40;
[fixedFeature, fixedValidInds] = extractFPFHFeatures(fixedDownsampled, ...
    'NumNeighbors', neighbors);
[movingFeature, movingValidInds] = extractFPFHFeatures(movingDownsampled, ...
    'NumNeighbors', neighbors);

fixedValidPts = select(fixedDownsampled, fixedValidInds);
movingValidPts = select(movingDownsampled, movingValidInds);

% Identify the point correspondences
method = 'Exhaustive';
threshold = 1;
ratio = 0.96;
indexPairs = pcmatchfeatures(movingFeature, fixedFeature, movingValidPts, ...
    fixedValidPts, "Method", method, "MatchThreshold", threshold, ...
    "RejectRatio", ratio);

matchedFixedPts = select(fixedValidPts, indexPairs(:, 2));
matchedMovingPts = select(movingValidPts, indexPairs(:, 1));

% Estimate rigid transform of moving point cloud with respect to reference
% point cloud
maxDist = 2;
maxNumTrails = 3000;
tform = estimateGeometricTransform3D(matchedMovingPts.Location, ...
    matchedFixedPts.Location, "rigid", "MaxDistance", maxDist, ...
    "MaxNumTrials", maxNumTrails);

% Transform the moving point cloud to the reference point cloud, to
% visualize the alignment before and after registration
movingReg = pctransform(movingProcessed, tform);

% Moving and fixed point clouds are represented by magenta and green colors
hFigAlign = figure;
axAlign1 = subplot(1, 2, 1, 'Color', [0 0 0], 'Parent', hFigAlign);
pcshowpair(movingProcessed, fixedProcessed, 'Parent', axAlign1);
title(axAlign1, 'Before Registration');
view(axAlign1, 2);

axAlign2 = subplot(1, 2, 2, 'Color', [0 0 0], 'Parent', hFigAlign);
pcshowpair(movingReg, fixedProcessed, 'Parent', axAlign2);
title(axAlign2, 'After Registration');
view(axAlign2, 2);
```



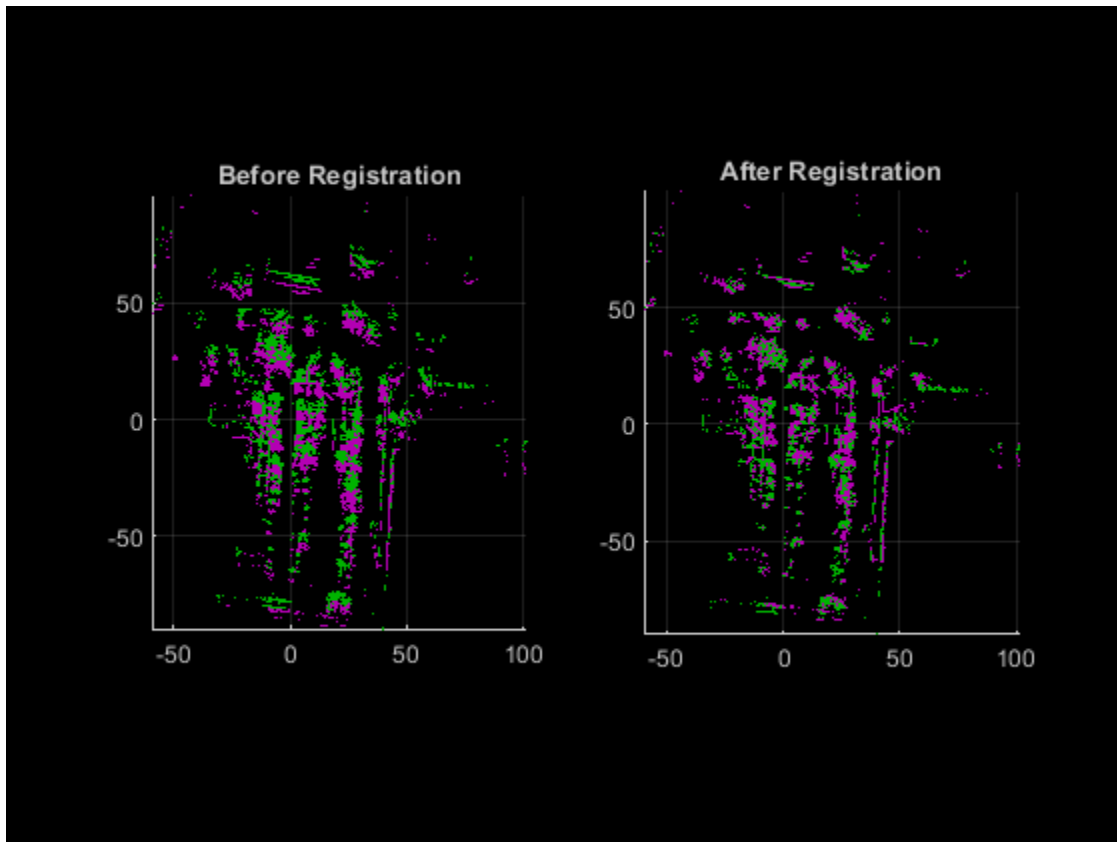

```
% Align and merge the point clouds
alignGridStep = 1;
ptCloudAccum = pcalign([fixedProcessed movingProcessed], ...
    [rigid3d tform],alignGridStep);

% Visualize the accumulated point cloud
hFigAccum = figure;
axAccum = axes('Parent',hFigAccum,'Color',[0 0 0]);

pcshow(ptCloudAccum,'Parent',axAccum);
title(axAccum,'Accumulated Point Cloud');
view(axAccum,2);
```

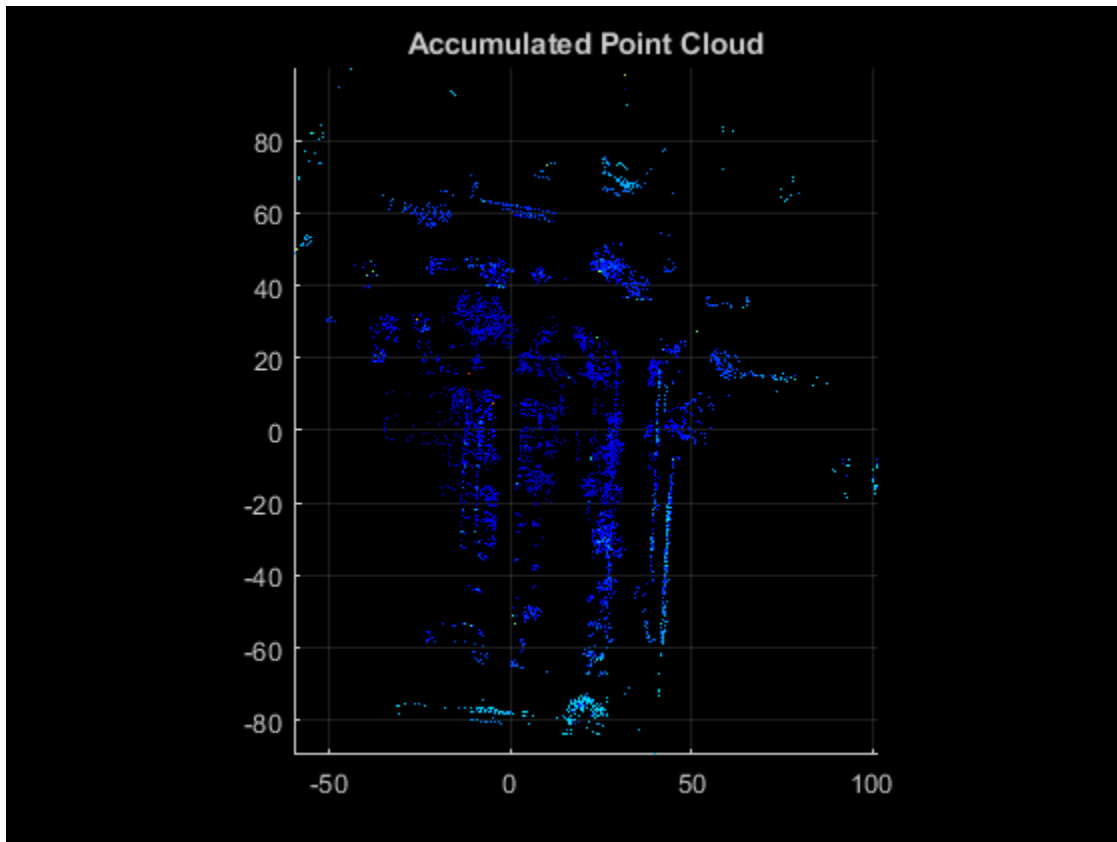

### Map Generation

Apply preprocessing and feature-based registration steps in a loop over the entire sequence of recorded data. The result is a map of the environment traversed by the vehicle.

```
rng('default');
numFrames = height(lidarPointClouds);
accumTform = rigid3d;
pointCloudMap = pointCloud(zeros(0,0,3));

% Specify limits for the player
xlims = [-200 250]; % meters
ylims = [-150 500];
zlims = [-100 100];

% Create a pcplayer to visualize map
mapPlayer = pcplayer(xlims,ylims,zlims);
title(mapPlayer.Axes,'Accumulated Map');
mapPlayer.Axes.View = [0 90];

% Loop over the entire data to generate map
for n = 1:skipFrames:numFrames-skipFrames

    % Get the nth point cloud
    ptCloud = lidarPointClouds.PointCloud(n);

    % Segment ground and remove ego vehicle
```

```

ptProcessed = helperProcessPointCloud(ptCloud);

% Downsample the point cloud for speed of operation
ptDownsampled = pcdownsampling(ptProcessed,"gridAverage",gridStep);

% Extract the features from point cloud
[ptFeature,ptValidInds] = extractFPFHFeatures(ptDownsampled, ...
    'NumNeighbors',neighbors);
ptValidPts = select(ptDownsampled,ptValidInds);

if n==1
    moving      = ptValidPts;
    movingFeature = ptFeature;
    pointCloudMap = ptValidPts;
else
    fixed      = moving;
    fixedFeature = movingFeature;
    moving      = ptValidPts;
    movingFeature = ptFeature;

    % Match the features to find correspondences
    indexPairs = pcmatchfeatures(movingFeature,fixedFeature,moving, ...
        fixed,"Method",method,"MatchThreshold",threshold, ...
        "RejectRatio",ratio);
    matchedFixedPts = select(fixed,indexPairs(:,2));
    matchedMovingPts = select(moving,indexPairs(:,1));

    % Register moving point cloud w.r.t reference point cloud
    tform = estimateGeometricTransform3D(matchedMovingPts.Location, ...
        matchedFixedPts.Location,"rigid","MaxDistance",maxDist, ...
        "MaxNumTrials",maxNumTrials);

    % Compute accumulated transformation to original reference frame
    accumTform = rigid3d(tform.T*accumTform.T);

    % Align and merge moving point cloud to accumulated map
    pointCloudMap = pcalign([pointCloudMap moving], ...
        [rigid3d accumTform],alignGridStep);
end

% Update map display
view(mapPlayer,pointCloudMap);
end

```

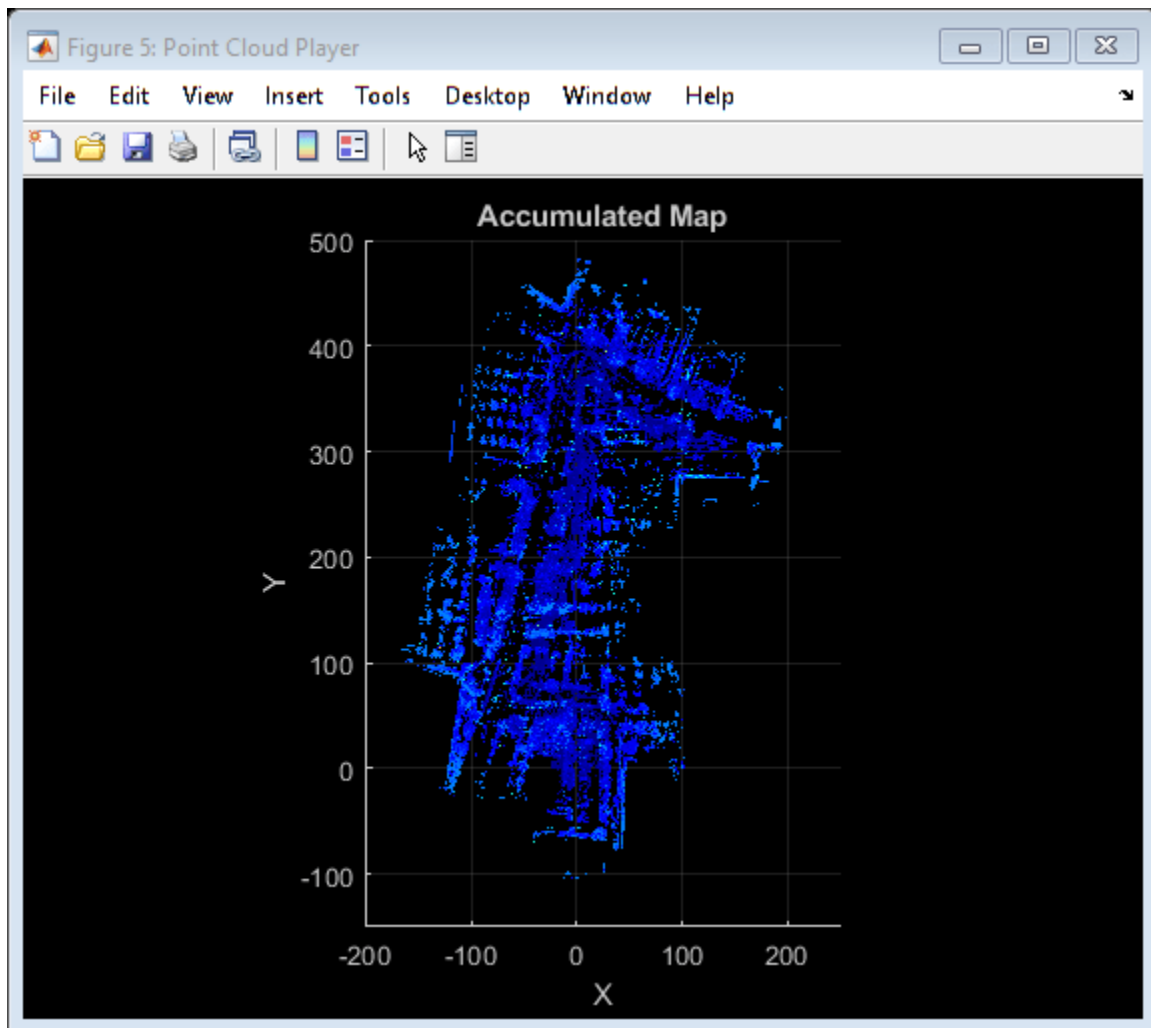

## Functions

`pcdownsample` | `extractFPFHFeatures` | `pcmatchfeatures` |  
`estimateGeometricTransform3D` | `pctransform` | `pcalign`

## Objects

`pcplayer` | `pointCloud`

## Related Topics

- “Build a Map from Lidar Data” (Automated Driving Toolbox)
- “Ground Plane and Obstacle Detection Using Lidar” (Automated Driving Toolbox)

## External Websites

- Udacity Self-Driving Car Data Subset (MathWorks GitHub repository)

## Detect Vehicles in Lidar Using Image Labels

This example shows you how to detect vehicles in lidar using label data from a co-located camera with known lidar-to-camera calibration parameters. Use this workflow in MATLAB® to estimate 3-D oriented bounding boxes in lidar based on 2-D bounding boxes in the corresponding image. You will also see how to automatically generate ground truth as a distance for 2-D bounding boxes in a camera image using lidar data. This figure provides an overview of the process.

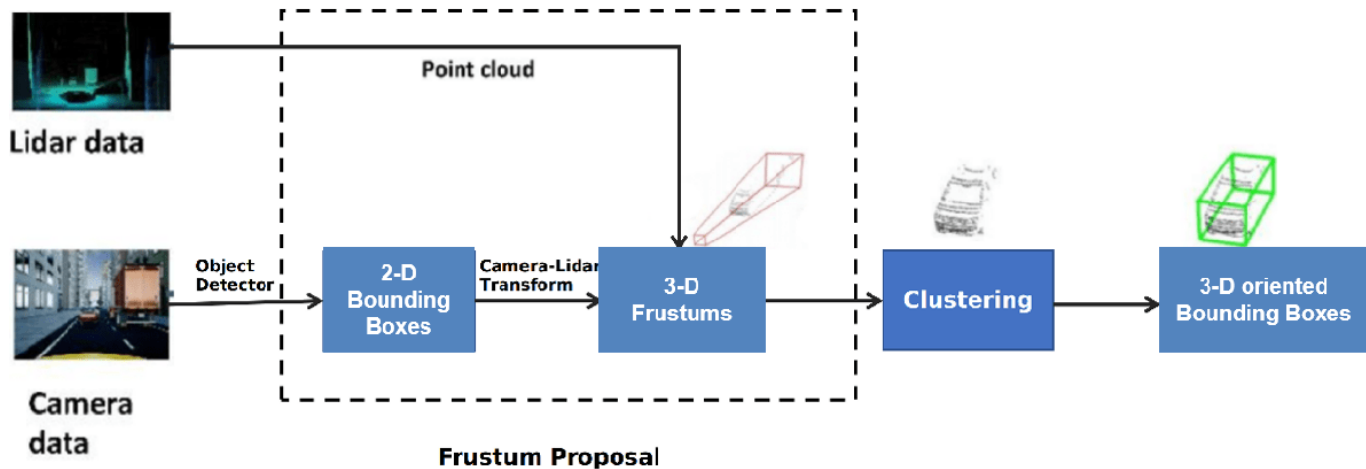

### Load Data

This example uses lidar data collected on a highway from an Ouster OS1 lidar sensor and image data from a front-facing camera mounted on the ego vehicle. The lidar and camera data are approximately time-synced and calibrated to estimate their intrinsic and extrinsic parameters. For more information on lidar camera calibration, see “Lidar and Camera Calibration” on page 1-119.

**Note:** The download time for the data depends on the speed of your internet connection. During the execution of this code block, MATLAB is temporarily unresponsive.

```

lidarTarFileUrl = 'https://www.mathworks.com/supportfiles/lidar/data/WPI_LidarData.tar.gz';
imageTarFileUrl = 'https://www.mathworks.com/supportfiles/lidar/data/WPI_ImageData.tar.gz';

outputFolder = fullfile(tempdir, 'WPI');
lidarDataTarFile = fullfile(outputFolder, 'WPI_LidarData.tar.gz');
imageDataTarFile = fullfile(outputFolder, 'WPI_ImageData.tar.gz');

if ~exist(outputFolder, 'dir')
    mkdir(outputFolder)
end

if ~exist(lidarDataTarFile, 'file')
    disp('Downloading WPI Lidar driving data (760 MB)...')
    websave(lidarDataTarFile, lidarTarFileUrl)
    untar(lidarDataTarFile, outputFolder)
end

% Check if lidar tar.gz file is downloaded, but not uncompressed.
if ~exist(fullfile(outputFolder, 'WPI_LidarData.mat'), 'file')

```

```
        untar(lidarDataTarFile,outputFolder)
    end

    if ~exist(imageDataTarFile,'file')
        disp('Downloading WPI Image driving data (225 MB)...')
        websave(imageDataTarFile,imageTarFileUrl)
        untar(imageDataTarFile,outputFolder)
    end

    % Check if image tar.gz file is downloaded, but not uncompressed.
    if ~exist(fullfile(outputFolder,'imageData'),'dir')
        untar(imageDataTarFile,outputFolder)
    end

    imageDataLocation = fullfile(outputFolder,'imageData');
    images = imageSet(imageDataLocation);
    imageFileNames = images.ImageLocation;

    % Load downloaded lidar data into the workspace
    lidarData = fullfile(outputFolder,'WPI_LidarData.mat');
    load(lidarData);

    % Load calibration data
    if ~exist('calib','var')
        load('calib.mat')
    end

    % Define camera to lidar transformation matrix
    camToLidar = calib.extrinsics;
    intrinsics = calib.intrinsics;
```

Alternatively, you can use your web browser to first download the datasets to your local disk, and then uncompress the files.

This example uses prelabeled data to serve as ground truth for the 2-D detections from the camera images. These 2-D detections can be generated using deep learning-based object detectors like `vehicleDetectorYOLOv2` (Automated Driving Toolbox), `vehicleDetectorFasterRCNN` (Automated Driving Toolbox), and `vehicleDetectorACF` (Automated Driving Toolbox). For this example, the 2-D detections have been generated using the Training Image Labeler app. These 2-D bounding boxes are vectors of the form:  $[x\ y\ w\ h]$ , where  $x$  and  $y$  represent the  $xy$ -coordinates of the top-left corner, and  $w$  and  $h$  represent the width and height of the bounding box respectively.

Read a image frame into the workspace, and display it with the bounding boxes overlaid.

```
load imageGTruth.mat
im = imread(imageFileNames{50});
imBbox = imageGTruth{50};

figure
imshow(im)
showShape('rectangle',imBbox)
```



### 3-D Region Proposal

To generate cuboid bounding boxes in lidar from the 2-D rectangular bounding boxes in the image data, a 3-D region is proposed to reduce the search space for bounding box estimation. The corners of each 2-D rectangular bounding box in the image are transformed into 3-D lines using camera intrinsic parameters and camera-to-lidar extrinsic parameters. These 3-D lines form frustum flaring out from the associated 2-D bounding box in the opposite direction of the ego vehicle. The lidar points that fall inside this region are segmented into various clusters based on Euclidean distance. The clusters are fitted with 3-D oriented bounding boxes, and the best cluster is estimated based on the size of these clusters. Estimate the 3-D oriented bounding boxes in a lidar point cloud, based on the 2-D bounding boxes in a camera image, by using the `bboxCameraToLidar` function. This figure shows how 2-D and 3-D bounding boxes relate to each other.



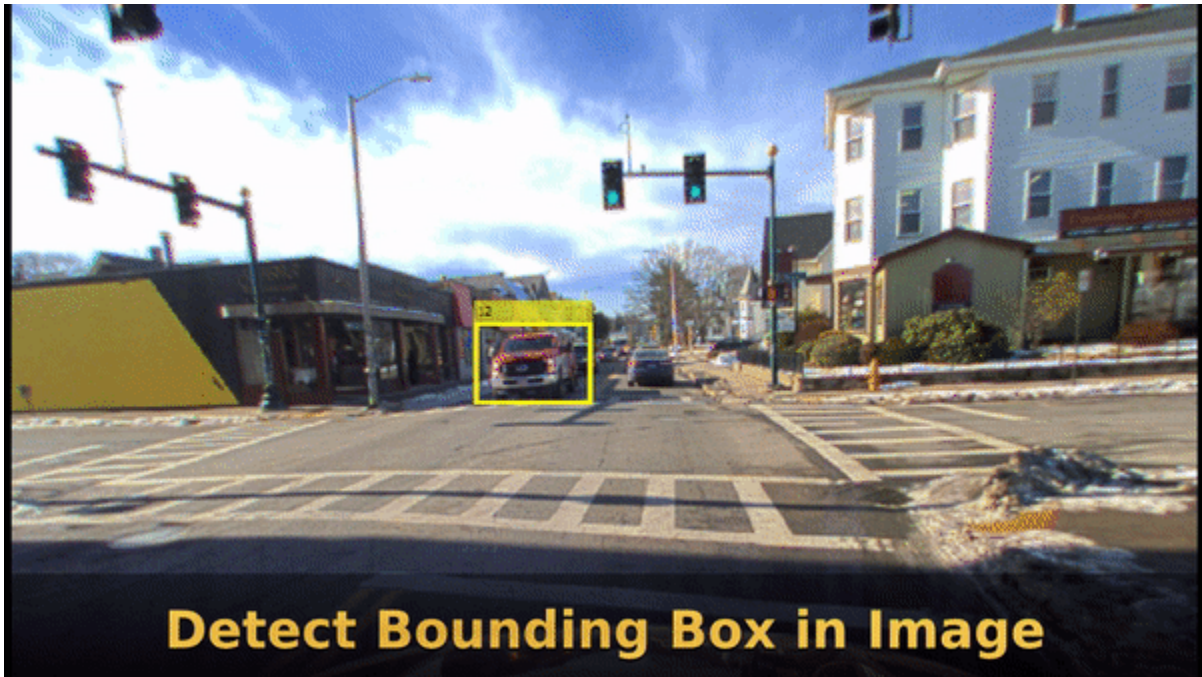

The 3-D cuboids are represented as vectors of the form:  $[xcen\ ycen\ zcen\ dimx\ dimy\ dimz\ rotx\ roty\ rotz]$ , where  $xcen$ ,  $ycen$ , and  $zcen$  represent the centroid coordinates of the cuboid.  $dimx$ ,  $dimy$ , and  $dimz$  represent the length of the cuboid along the  $x$ -,  $y$ -, and  $z$ -axes, and  $rotx$ ,  $roty$ , and  $rotz$  represent the rotation, in degrees, of the cuboid along the  $x$ -,  $y$ -, and  $z$ -axes.

Use ground truth of the image to estimate a 3-D bounding box in the lidar point cloud.

```
pc = lidarData{50};

% Crop point cloud to process only front region
roi = [0 70 -15 15 -3 8];
ind = findPointsInROI(pc,roi);
pc = select(pc,ind);

lidarBbox = bboxCameraToLidar(imBbox,pc,intrinsics, ...
    camToLidar,'ClusterThreshold',2,'MaxDetectionRange',[1,70]);
figure
pcshow(pc.Location,pc.Location(:,3))
showShape('Cuboid',lidarBbox)
view([-2.90 71.59])
```



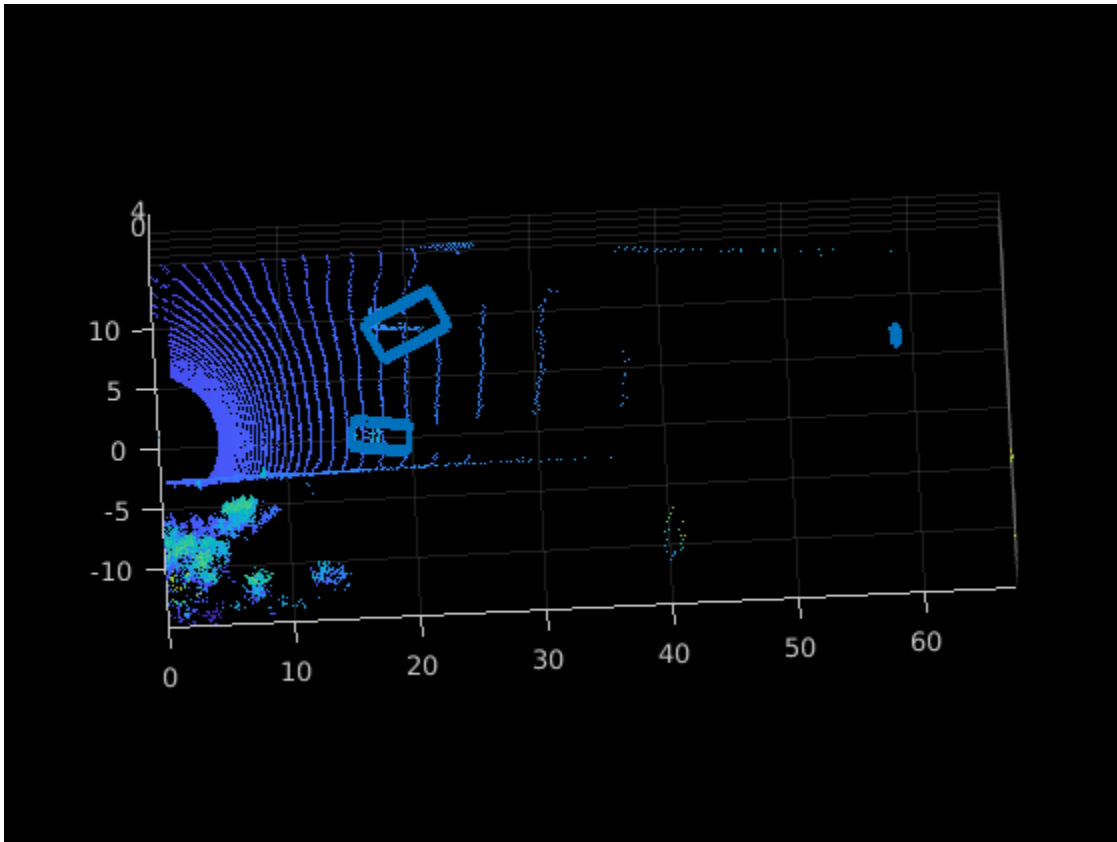

To improve the detected bounding boxes, preprocess the point cloud by removing the ground plane.

### Set Up Display

Use the `helperLidarCameraObjectsDisplay` class to visualize the lidar and image data. This visualization provides the capability to view the point cloud, image, 3-D bounding boxes on the point cloud, and 2-D bounding boxes on the image simultaneously. The visualization layout consists of these windows:

- Image — Visualize an image and associated 2-D bounding boxes
- Perspective View — Visualize the point cloud and associated 3-D bounding boxes in a perspective view
- Top View — Visualize the point cloud and associated 3-D bounding boxes from the top view

```
% Initialize display
display = helperLidarCameraObjectsDisplay;
initializeDisplay(display)
```

```
% Update display with point cloud and image
updateDisplay(display, im, pc)
```

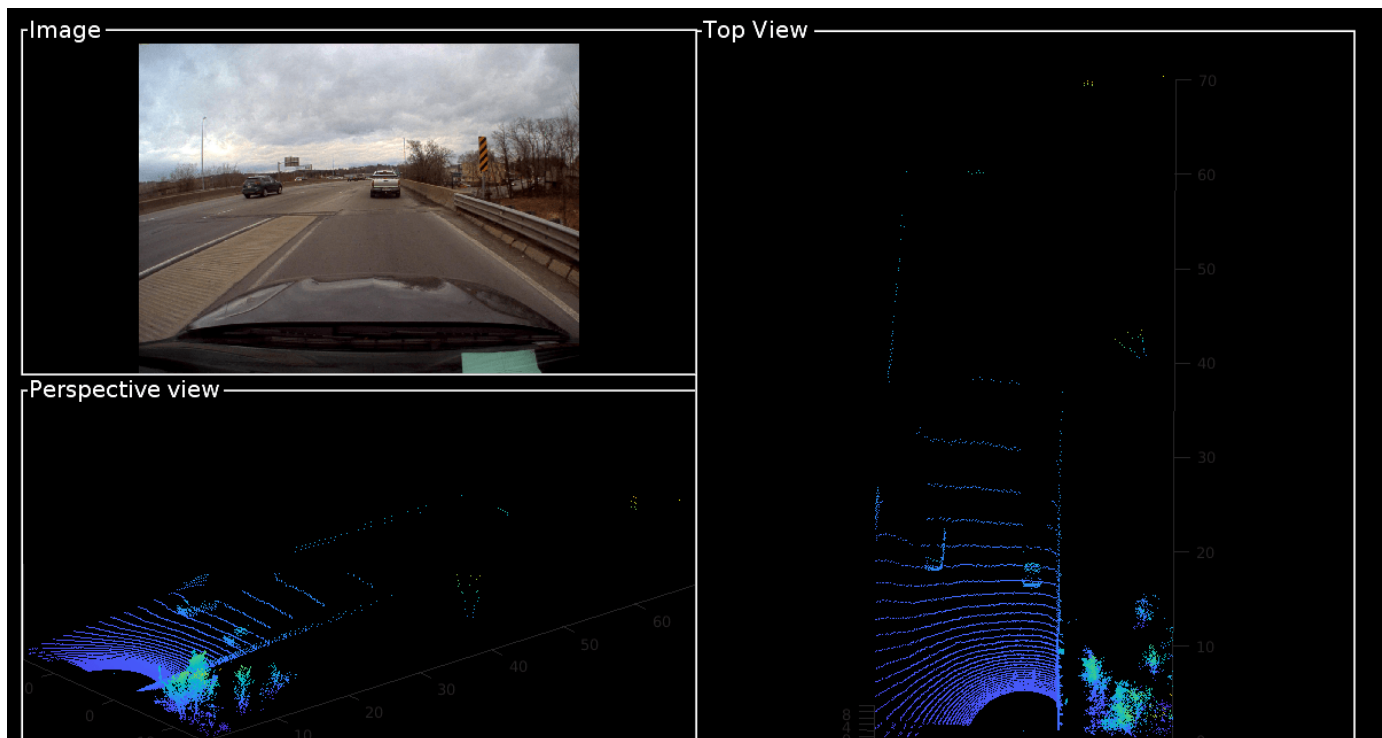

### Loop Through Data

Run `bboxCameraToLidar` on 2-D labels over first 200 frames to generate 3-D cuboids

```

for i = 1:200
    % Load point cloud and image
    im = imread(imageFileNames{i});
    pc = lidarData{i};

    % Load image ground truth
    imBbox = imageGTruth{i};

    % Remove ground plane
    groundPtsIndex = segmentGroundFromLidarData(pc,'ElevationAngleDelta',15, ...
        'InitialElevationAngle',10);
    nonGroundPts = select(pc,~groundPtsIndex);

    if imBbox
        [lidarBbox,~,boxUsed] = bboxCameraToLidar(imBbox,nonGroundPts,intrinsics, ...
            camToLidar,'ClusterThreshold',2,'MaxDetectionRange',[1, 70]);
        % Display image with bounding boxes
        im = updateImage(display,im,imBbox);
    end
    % Display point cloud with bounding box
    updateDisplay(display,im,pc);
    updateLidarBbox(display,lidarBbox,boxUsed)
    drawnow
end

```



Detected bounding boxes by using bounding box tracking, such as joint probabilistic data association (JPDA). For more information, see “Track Vehicles Using Lidar: From Point Cloud to Track List” on page 1-224.

### Estimate the Distance of Vehicles from the Ego Vehicle

For vehicle safety features such as forward collision warning, accurate measurement of the distance between the ego vehicle and other objects is crucial. A lidar sensor provides the accurate distance of objects from the ego vehicle in 3-D, and it can also be used to create ground truth automatically from 2-D image bounding boxes. To generate ground truth for 2-D bounding boxes, use the `projectLidarPointsOnImage` function to project the points inside the 3-D bounding boxes onto the image. The projected points are associated with 2-D bounding boxes by finding the bounding box with the minimum Euclidean distance from the projected 3-D points. Since the projected points are from lidar to camera, use the inverse of camera-to-lidar extrinsic parameters. This figure illustrates the transformation from lidar to camera.

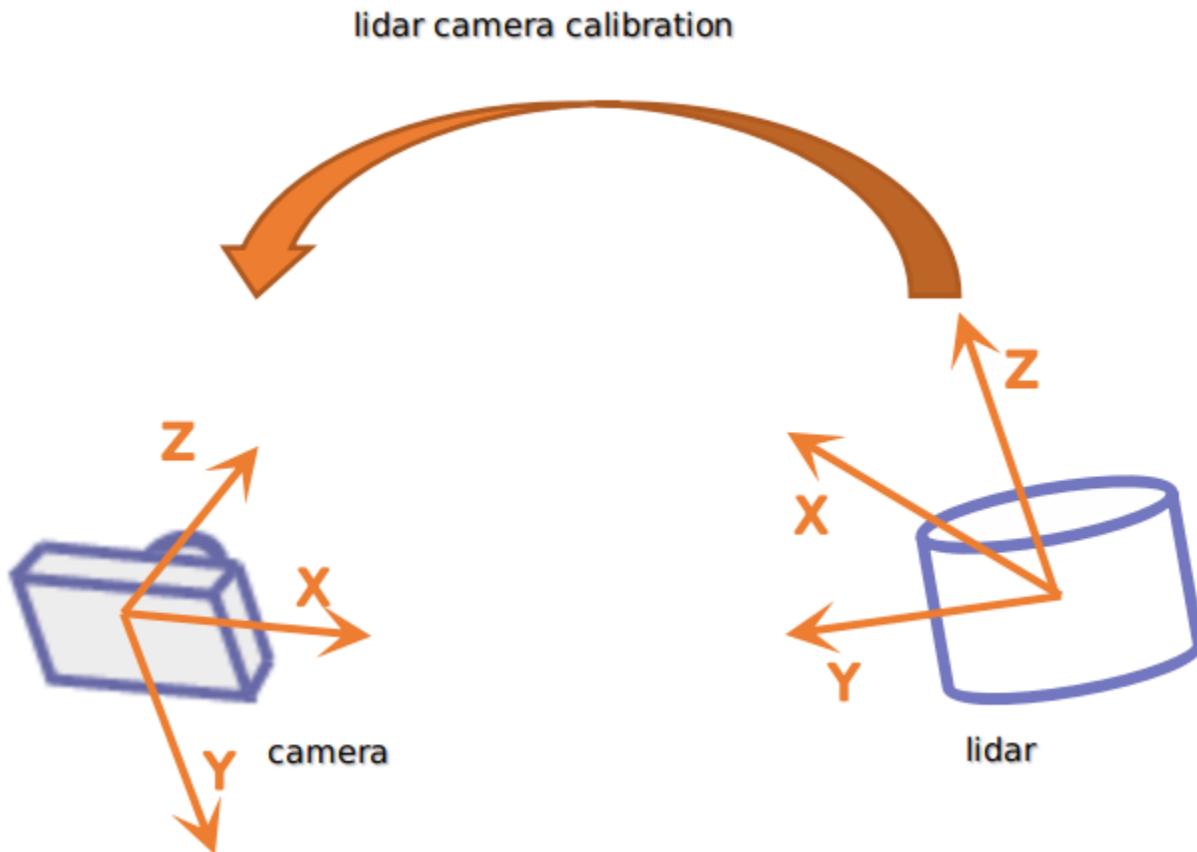

```

% Initialize display
display = helperLidarCameraObjectsDisplay;
initializeDisplay(display)

% Get lidar to camera matrix
lidarToCam = invert(camToLidar);

% Loop first 200 frames. To loop all frames, replace 200 with numel(imageGTruth)
for i = 1:200
    im = imread(imageFileNames{i});
    pc = lidarData{i};
    imBbox = imageGTruth{i};

    % Remove ground plane
    groundPtsIndex = segmentGroundFromLidarData(pc,'ElevationAngleDelta',15, ...
        'InitialElevationAngle',10);
    nonGroundPts = select(pc,~groundPtsIndex);

    if imBbox
        [lidarBbox,~,boxUsed] = bboxCameraToLidar(imBbox,nonGroundPts,intrinsics, ...
            camToLidar,'ClusterThreshold',2,'MaxDetectionRange',[1, 70]);
        [distance,nearestRect,idx] = helperComputeDistance(imBbox,nonGroundPts,lidarBbox, ...
            intrinsics,lidarToCam);

        % Update image with bounding boxes
        im = updateImage(display,im,nearestRect,distance);
    end
end

```

```

        updateLidarBbox(display,lidarBbox)
    end

    % Update display
    updateDisplay(display,im,pc)
    drawnow
end

```

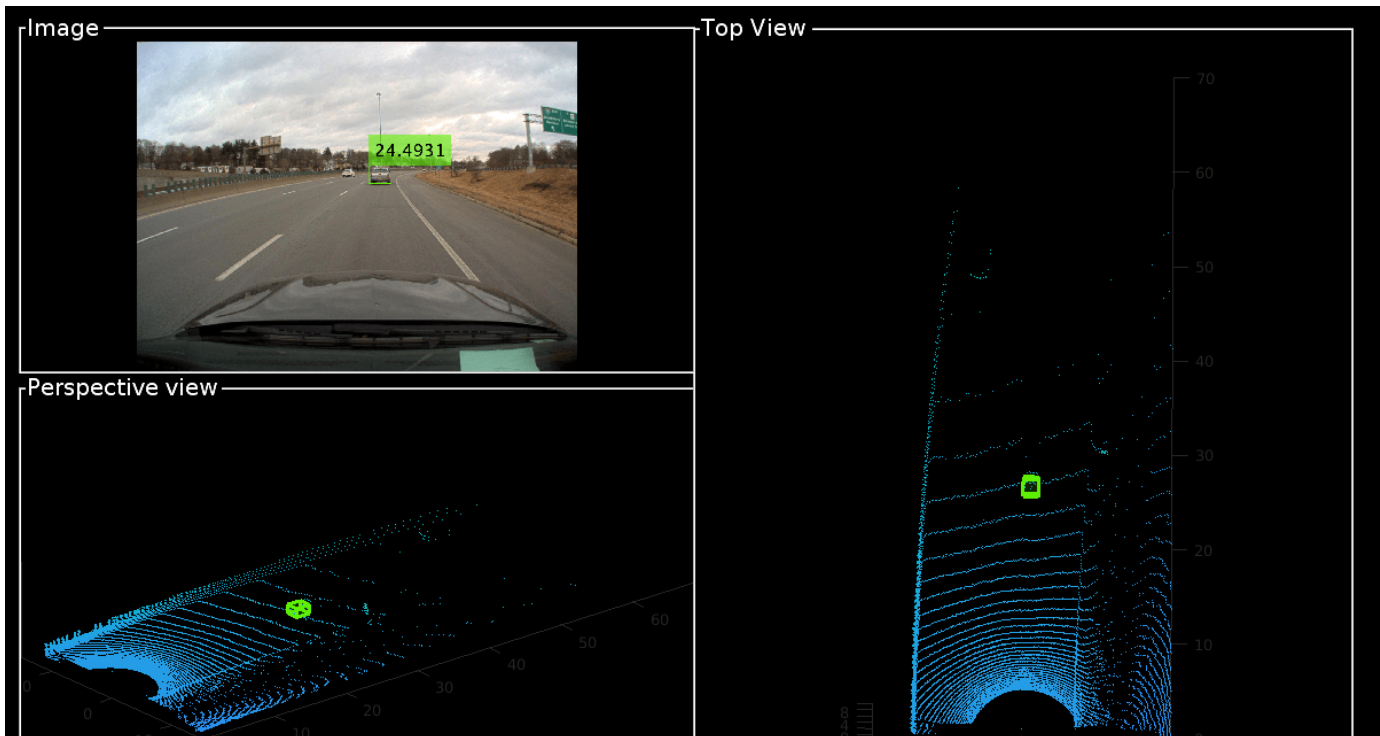

## Supporting Files

### helperComputeDistance

```

function [distance, nearestRect, index] = helperComputeDistance(imBbox, pc, lidarBbox, intrinsic)
% helperComputeDistance estimates the distance of 2-D bounding box in a given
% image using 3-D bounding boxes from lidar. It also calculates
% association between 2-D and 3-D bounding boxes

% Copyright 2020 MathWorks, Inc.

numLidarDetections = size(lidarBbox,1);

nearestRect = zeros(0,4);
distance = zeros(1,numLidarDetections);
index = zeros(0,1);

for i = 1:numLidarDetections
    bboxCuboid = lidarBbox(i,:);

    % Create cuboidModel
    model = cuboidModel(bboxCuboid);

```

```
% Find points inside cuboid
ind = findPointsInsideCuboid(model,pc);
pts = select(pc,ind);

% Project cuboid points to image
imPts = projectLidarPointsOnImage(pts,intrinsic,lidarToCam);

% Find 2-D rectangle corresponding to 3-D bounding box
[nearestRect(i,:),idx] = findNearestRectangle(imPts,imBbox);
index(end+1) = idx;
% Find the distance of the 2-D rectangle
distance(i) = min(pts.Location(:,1));
end
end

function [nearestRect,idx] = findNearestRectangle(imPts,imBbox)
numBbox = size(imBbox,1);
ratio = zeros(numBbox,1);

% Iterate over all the rectangles
for i = 1:numBbox
    bbox = imBbox(i,:);
    corners = getCornersFromBbox(bbox);

    % Find overlapping ratio of the projected points and the rectangle
    idx = (imPts(:,1) > corners(1,1)) & (imPts(:,1) < corners(2,1)) & ...
        (imPts(:,2) > corners(1,2)) & (imPts(:,2) < corners(3,1));
    ratio(i) = sum(idx);
end

% Get nearest rectangle
[~,idx] = max(ratio);
nearestRect = imBbox(idx,:);
end

function cornersCamera = getCornersFromBbox(bbox)
cornersCamera = zeros(4,2);
cornersCamera(1,1:2) = bbox(1:2);
cornersCamera(2,1:2) = bbox(1:2) + [bbox(3),0];
cornersCamera(3,1:2) = bbox(1:2) + bbox(3:4);
cornersCamera(4,1:2) = bbox(1:2) + [0,bbox(4)];
end
```

## Lidar Point Cloud Semantic Segmentation Using SqueezeSegV2 Deep Learning Network

This example shows how to train a SqueezeSegV2 semantic segmentation network on 3-D organized lidar point cloud data.

SqueezeSegV2 [1 on page 1-0 ] is a convolutional neural network (CNN) for performing end-to-end semantic segmentation of an organized lidar point cloud. The training procedure shown in this example requires 2-D spherical projected images as inputs to the deep learning network.

This example uses PandaSet data set from Hesai and Scale [2] on page 1-0 . The PandaSet contains 4800 unorganized lidar point cloud scans of the various city scenes captured using the Pandar 64 sensor. The data set provides semantic segmentation labels for 42 different classes including car, road, and pedestrian.

### Download Lidar Data Set

This example uses a subset of PandaSet, that contains 2560 preprocessed organized point clouds. Each point cloud is specified as a 64-by-1856 matrix. The corresponding ground truth contains the semantic segmentation labels for 12 classes. The point clouds are stored in PCD format, and the ground truth data is stored in PNG format. The size of the data set is 5.2 GB. Execute this code to download the data set.

```
url = "https://ssd.mathworks.com/supportfiles/lidar/data/Pandaset_LidarData.tar.gz";
outputFolder = fullfile(tempdir,"Pandaset");
lidarDataTarFile = fullfile(outputFolder,"Pandaset_LidarData.tar.gz");
if ~exist(lidarDataTarFile,"file")
    mkdir(outputFolder);
    disp("Downloading Pandaset Lidar driving data (5.2 GB)...");
    websave(lidarDataTarFile,url);
    untar(lidarDataTarFile,outputFolder);
end
% Check if tar.gz file is downloaded, but not uncompressed.
if (~exist(fullfile(outputFolder,"Lidar"),"file"))...
    &&(~exist(fullfile(outputFolder,"semanticLabels"),"file"))
    untar(lidarDataTarFile,outputFolder);
end
lidarData = fullfile(outputFolder,"Lidar");
labelsFolder = fullfile(outputFolder,"semanticLabels");
```

Depending on your Internet connection, the download process can take some time. The code suspends MATLAB® execution until the download process is complete. Alternatively, you can download the data set to your local disk using your web browser, and then extract Pandaset\_LidarData folder. The Pandaset\_LidarData contains Lidar, Cuboids and semanticLabels folders that holds the point clouds, cuboid label and semantic label info respectively. To use the file you downloaded from the web, change the outputFolder variable in the code to the location of the downloaded file.

The training procedure for this example is for organized point clouds. For an example showing how to convert unorganized to organized point clouds, see “Unorganized to Organized Conversion of Point Clouds Using Spherical Projection” on page 1-265.

## Download Pretrained Network

Download the pretrained network to avoid having to wait for training to complete. If you want to train the network, set the `doTraining` variable to `true`.

```
doTraining = false;
pretrainedNetURL = ...
"https://ssd.mathworks.com/supportfiles/lidar/data/trainedSqueezeSegV2PandasetNet.zip";
if ~doTraining
    downloadPretrainedSqueezeSegV2Net(outputFolder,pretrainedNetURL);
end
```

Downloading pretrained model (5 MB)...

## Prepare Data for Training

### Load Lidar Point Clouds and Class Labels

Use the `helperTransformOrganizedPointCloudToTrainingData` supporting function, attached to this example, to generate training data from the lidar point clouds. The function uses point cloud data to create five-channel input images. Each training image is specified as a 64-by-1856-by-5 array:

- The height of each image is 64 pixels.
- The width of each image is 1856 pixels.
- Each image has five channels. The five channels specify the 3-D coordinates of the point cloud, intensity, and range:  $r = \sqrt{x^2 + y^2 + z^2}$ .

A visual representation of the training data follows.

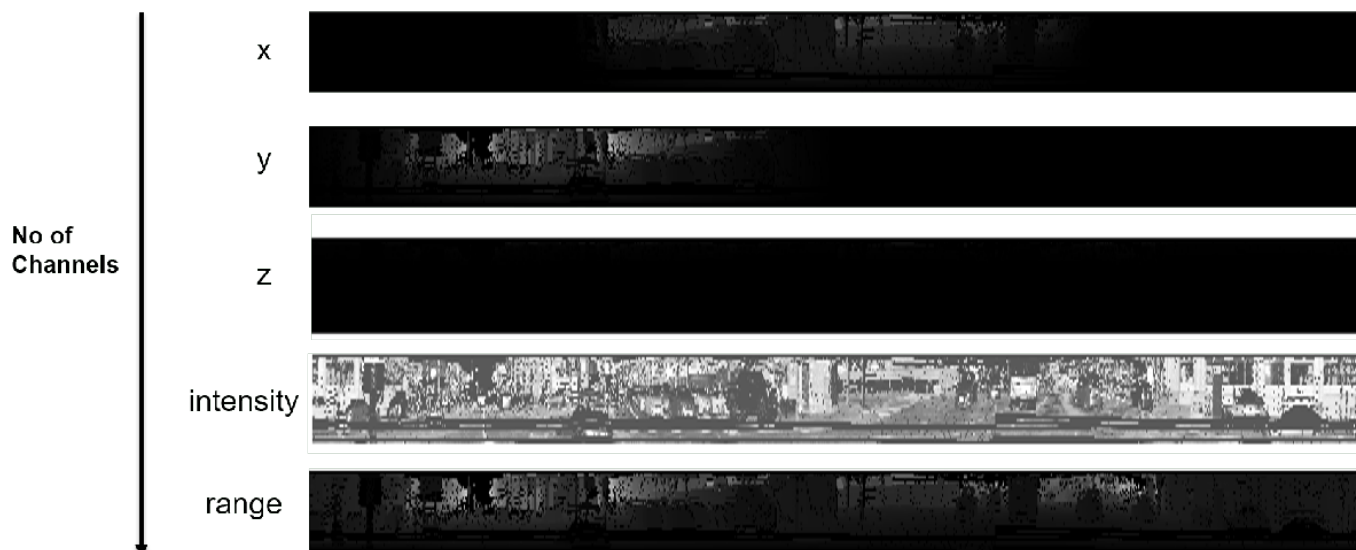

Generate the five-channel training images.

```
imagesFolder = fullfile(outputFolder,"images");
helperTransformOrganizedPointCloudToTrainingData(lidarData,imagesFolder);
```

Preprocessing data 100% complete



The five-channel images are saved as MAT files.

Processing can take some time. The code suspends MATLAB® execution until processing is complete.

### Create imageDatastore and pixelLabelDatastore

Create an `imageDatastore` to extract and store the five channels of the 2-D spherical images using `imageDatastore` and the `helperImageMatReader` supporting function, which is a custom MAT file reader. This function is attached to this example as a supporting file.

```
imds = imageDatastore(imagesFolder, ...
    "FileExtensions",".mat", ...
    "ReadFcn",@helperImageMatReader);
```

Create a pixel label datastore using `pixelLabelDatastore` to store pixel-wise labels from the pixel label images. The object maps each pixel label to a class name. In this example, the vegetation, ground, road, road markings, sidewalk, cars, trucks, other vehicles, pedestrian, road barrier, signs, and buildings are the objects of interest; all other pixels are the background. Specify these classes and assign a unique label ID to each class.

```
classNames = ["unlabelled"
    "Vegetation"
    "Ground"
    "Road"
    "RoadMarkings"
    "SideWalk"
    "Car"
    "Truck"
    "OtherVehicle"
    "Pedestrian"
    "RoadBarriers"
    "Signs"
    "Buildings"];
numClasses = numel(classNames);
% Specify label IDs from 1 to the number of classes.
labelIDs = 1 : numClasses;
pxds = pixelLabelDatastore(labelsFolder,classNames,labelIDs);
```

Load and display one of the labeled images by overlaying it on the corresponding intensity image using the `helperDisplayLidarOverlaidImage` function, defined in the Supporting Functions on page 1-0 section of this example.

```
% Point cloud (channels 1, 2, and 3 are for location, channel 4 is for intensity, and channel 5 :
I = read(imds);
labelMap = read(pxds);
figure;
helperDisplayLidarOverlaidImage(I,labelMap{1,1},classNames);
title("Ground Truth");
```

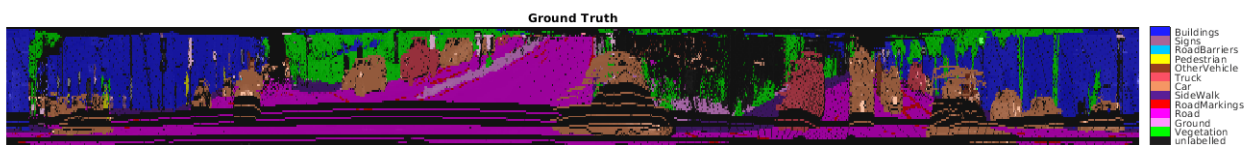

## Prepare Training, Validation, and Test Sets

Use the `helperPartitionLidarSegmentationDataset` supporting function, attached to this example, to split the data into training, validation, and test sets. You can split the training data according to the percentage specified by the `trainingDataPercentage`. Divide the rest of the data in a 2:1 ratio into validation and testing data. Default value of `trainingDataPercentage` is 0.7.

```
[imdsTrain,imdsVal,imdsTest,pxdsTrain,pxdsVal,pxdsTest] = ...  
helperPartitionLidarSegmentationDataset(imds,pxds,"trainingDataPercentage",0.75);
```

Use the `combine` function to combine the pixel label and image datastores for the training and validation data.

```
trainingData = combine(imdsTrain,pxdsTrain);  
validationData = combine(imdsVal,pxdsVal);
```

## Data Augmentation

Data augmentation is used to improve network accuracy by randomly transforming the original data during training. By using data augmentation, you can add more variety to the training data without actually having to increase the number of labeled training samples.

Augment the training data by using the `transform` function with custom preprocessing operations specified by the `helperAugmentData` function, defined in the Supporting Functions on page 1-0 section of this example. This function randomly flips the multichannel 2-D image and associated labels in the horizontal direction. Apply data augmentation to only the training data set.

```
augmentedTrainingData = transform(trainingData,@(x) helperAugmentData(x));
```

## Define Network Architecture

Create a standard SqueezeSegV2 [1 on page 1-0 ] network by using the `squeezesegv2Layers` function. In the SqueezeSegV2 network, the encoder subnetwork consists of FireModules interspersed with max-pooling layers. This arrangement successively decreases the resolution of the input image. In addition, the SqueezeSegV2 network uses the *focal loss* function to mitigate the effect of the imbalanced class distribution on network accuracy. For more details on how to use the focal loss function in semantic segmentation, see `focalLossLayer`.

Execute this code to create a layer graph that can be used to train the network.

```
inputSize = [64 1856 5];  
lgraph = squeezesegv2Layers(inputSize, ...  
numClasses,"NumEncoderModules",4,"NumContextAggregationModules",2);
```

Use the `analyzeNetwork` (Deep Learning Toolbox) function to display an interactive visualization of the network architecture.

```
analyzeNetwork(lgraph);
```

## Specify Training Options

Use the Adam optimization algorithm to train the network. Use the `trainingOptions` (Deep Learning Toolbox) function to specify the hyperparameters.

```
maxEpochs = 30;  
initialLearningRate = 1e-3;  
miniBatchSize = 8;
```

```

l2reg = 2e-4;
options = trainingOptions("adam", ...
    "InitialLearnRate",initialLearningRate, ...
    "L2Regularization",l2reg, ...
    "MaxEpochs",maxEpochs, ...
    "MiniBatchSize",miniBatchSize, ...
    "LearnRateSchedule","piecewise", ...
    "LearnRateDropFactor",0.1, ...
    "LearnRateDropPeriod",10, ...
    "ValidationData",validationData, ...
    "Plots","training-progress", ...
    "VerboseFrequency",20);

```

Note: Reduce the miniBatchSize value to control memory usage when training.

### Train Network

You can train the network yourself by setting the doTraining argument to true. If you train the network, you can use a CPU or a GPU. Using a GPU requires Parallel Computing Toolbox™ and a supported GPU device. For information on supported devices, see “GPU Support by Release” (Parallel Computing Toolbox). Otherwise, load a pretrained network.

```

if doTraining
    [net,info] = trainNetwork(trainingData,lgraph,options);
else
    load(fullfile(outputFolder,"trainedSqueezeSegV2PandasetNet.mat"),"net");
end

```

### Predict Results on Test Point Cloud

Use the trained network to predict results on a test point cloud and display the segmentation result. First, read a five-channel input image and predict the labels using the trained network.

Display the figure with the segmentation as an overlay.

```

I = read(imdsTest);
predictedResult = semanticseg(I,net);
figure;
helperDisplayLidarOverlaidImage(I,predictedResult,classNames);
title("Semantic Segmentation Result");

```

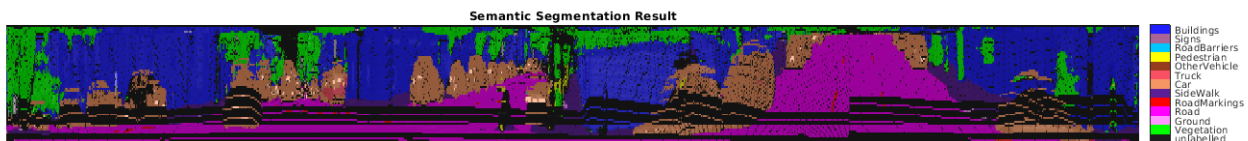

Use the helperDisplayLabelOverlaidPointCloud function, defined in the Supporting Functions on page 1-0 section of this example, to display the segmentation result on the point cloud.

```

figure;
helperDisplayLabelOverlaidPointCloud(I,predictedResult);
view([39.2 90.0 60]);
title("Semantic Segmentation Result on Point Cloud");

```

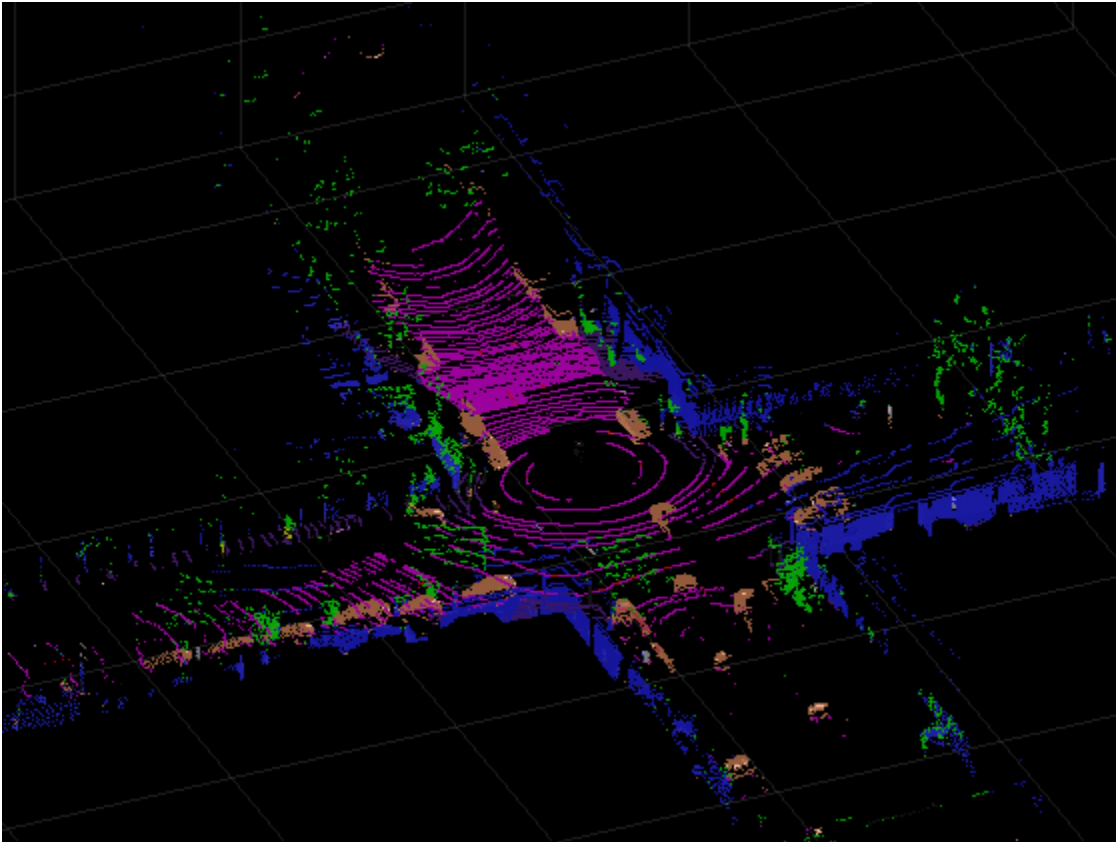

### Evaluate Network

Use the `evaluateSemanticSegmentation` function to compute the semantic segmentation metrics from the test set results.

```
outputLocation = fullfile(tempdir,"output");
if ~exist(outputLocation,"dir")
    mkdir(outputLocation);
end
pxdsResults = semanticseg(imdsTest,net, ...
    "MiniBatchSize",4, ...
    "WriteLocation",outputLocation, ...
    "Verbose",false);
metrics = evaluateSemanticSegmentation(pxdsResults,pxdsTest,"Verbose",false);
```

You can measure the amount of overlap per class using the intersection-over-union (IoU) metric.

The `evaluateSemanticSegmentation` function returns metrics for the entire data set, for individual classes, and for each test image. To see the metrics at the data set level, use the `metrics.DataSetMetrics` property.

```
metrics.DataSetMetrics
```

```
ans=1x5 table
   GlobalAccuracy   MeanAccuracy   MeanIoU   WeightedIoU   MeanBFScore
```

0.89724                      0.61685                      0.54431                      0.81806                      0.74537

The data set metrics provide a high-level overview of network performance. To see the impact each class has on the overall performance, inspect the metrics for each class using the `metrics.ClassMetrics` property.

`metrics.ClassMetrics`

ans=13×3 table

	Accuracy	IoU	MeanBFScore
unlabelled	0.94	0.9005	0.99911
Vegetation	0.77873	0.64819	0.95466
Ground	0.69019	0.59089	0.60657
Road	0.94045	0.83663	0.99084
RoadMarkings	0.37802	0.34149	0.77073
Sidewalk	0.7874	0.65668	0.93687
Car	0.9334	0.81065	0.95448
Truck	0.30352	0.27401	0.37273
OtherVehicle	0.64397	0.58108	0.47253
Pedestrian	0.26214	0.20896	0.45918
RoadBarriers	0.23955	0.21971	0.19433
Signs	0.17276	0.15613	0.44275
Buildings	0.94891	0.85117	0.96929

Although the overall network performance is good, the class metrics for some classes like RoadMarkings and Truck indicate that more training data is required for better performance.

## Supporting Functions

### Function to Augment Data

The `helperAugmentData` function randomly flips the spherical image and associated labels in the horizontal direction.

```
function out = helperAugmentData(inp)
% Apply random horizontal flipping.
out = cell(size(inp));
% Randomly flip the five-channel image and pixel labels horizontally.
I = inp{1};
sz = size(I);
tform = randomAffine2d("XReflection",true);
rout = affineOutputView(sz,tform,"BoundsStyle","centerOutput");
out{1} = imwarp(I,tform,"OutputView",rout);
out{2} = imwarp(inp{2},tform,"OutputView",rout);
end
```

### Function to Display Lidar Segmentation Map Overlaid on 2-D Spherical Image

The `helperDisplayLidarOverlaidImage` function overlays the semantic segmentation map over the intensity channel of the 2-D spherical image. The function also resizes the overlaid image for better visualization.

```
function helperDisplayLidarOverlaidImage(lidarImage,labelMap,classNames)
% helperDisplayLidarOverlaidImage(lidarImage, labelMap, classNames)
```

```
% displays the overlaid image. lidarImage is a five-channel lidar input.
% labelMap contains pixel labels and classNames is an array of label
% names.
% Read the intensity channel from the lidar image.
intensityChannel = uint8(lidarImage(:,:,4));
% Load the lidar color map.
cmap = helperPandasetColorMap;
% Overlay the labels over the intensity image.
B = labeloverlay(intensityChannel,labelMap,"Colormap",cmap,"Transparency",0.4);
% Resize for better visualization.
B = imresize(B,"Scale",[3 1],"method","nearest");
imshow(B);
helperPixelLabelColorbar(cmap,classNames);
end
```

### Function to Display Lidar Segmentation Map Overlaid on 3-D Point Cloud

The `helperDisplayLabelOverlaidPointCloud` function overlays the segmentation result over a 3-D organized point cloud.

```
function helperDisplayLabelOverlaidPointCloud(I,predictedResult)
% helperDisplayLabelOverlaidPointCloud(I, predictedResult)
% displays the overlaid pointCloud object. I is the 5 channels organized
% input image. predictedResult contains pixel labels.
ptCloud = pointCloud(I(:,:,1:3),"Intensity",I(:,:,4));
cmap = helperPandasetColorMap;
B = ...
labeloverlay(uint8(ptCloud.Intensity),predictedResult,"Colormap",cmap,"Transparency",0.4);
pc = pointCloud(ptCloud.Location,"Color",B);
figure;
ax = pcshow(pc);
set(ax,"XLim",[-70 70],"YLim",[-70 70]);
zoom(ax,3.5);
end
```

### Function to Define Lidar Colormap

The `helperPandasetColorMap` function defines the colormap used by the lidar data set.

```
function cmap = helperPandasetColorMap
cmap = [[30 30 30]; % Unlabeled
[0 255 0]; % Vegetation
[255 150 255]; % Ground
[255 0 255]; % Road
[255 0 0]; % Road Markings
[90 30 150]; % Sidewalk
[245 150 100]; % Car
[250 80 100]; % Truck
[150 60 30]; % Other Vehicle
[255 255 0]; % Pedestrian
[0 200 255]; % Road Barriers
[170 100 150]; % Signs
[30 30 255]]; % Building
cmap = cmap./255;
end
```

### Function to Display Pixel Label Colorbar

The `helperPixelLabelColorbar` function adds a colorbar to the current axis. The colorbar is formatted to display the class names with the color.

```
function helperPixelLabelColorbar(cmap,classNames)
colormap(gca,cmap);
% Add a colorbar to the current figure.
c = colorbar("peer",gca);
% Use class names for tick marks.
c.TickLabels = classNames;
numClasses = size(classNames,1);
% Center tick labels.
c.Ticks = 1/(numClasses*2):1/numClasses:1;
% Remove tick marks.
c.TickLength = 0;
end
```

### Function to Download Pretrained Model

The `downloadPretrainedSqueezeSegV2Net` function downloads the pretrained model.

```
function downloadPretrainedSqueezeSegV2Net(outputFolder,pretrainedNetURL)
preTrainedMATFile = fullfile(outputFolder,"trainedSqueezeSegV2PandasetNet.mat");
preTrainedZipFile = fullfile(outputFolder,"trainedSqueezeSegV2PandasetNet.zip");

if ~exist(preTrainedMATFile,"file")
    if ~exist(preTrainedZipFile,"file")
        disp("Downloading pretrained model (5 MB)...");
        websave(preTrainedZipFile,pretrainedNetURL);
    end
    unzip(preTrainedZipFile,outputFolder);
end
end
```

### References

[1] Wu, Bichen, Xuanyu Zhou, Sicheng Zhao, Xiangyu Yue, and Kurt Keutzer. "SqueezeSegV2: Improved Model Structure and Unsupervised Domain Adaptation for Road-Object Segmentation from a LiDAR Point Cloud." In *2019 International Conference on Robotics and Automation (ICRA)*, 4376-82. Montreal, QC, Canada: IEEE, 2019. <https://doi.org/10.1109/ICRA.2019.8793495>.

[2] Hesai and Scale. PandaSet. <https://scale.com/open-datasets/pandaset>

## Code Generation for Lidar Point Cloud Segmentation Network

This example shows how to generate CUDA® MEX code for a deep learning network for lidar semantic segmentation. This example uses a pretrained SqueezeSegV2 [1] network that can segment organized lidar point clouds belonging to three classes (*background*, *car*, and *truck*). For information on the training procedure for the network, see “Lidar Point Cloud Semantic Segmentation Using SqueezeSegV2 Deep Learning Network” on page 1-173. The generated MEX code takes a point cloud as input and performs prediction on the point cloud by using the `DAGNetwork` object for the SqueezeSegV2 network.

### Third-Party Prerequisites

#### Required

This example generates CUDA MEX and has the following third-party requirements.

- CUDA enabled NVIDIA® GPU and compatible driver.

#### Optional

For non-MEX builds such as static, dynamic libraries or executables, this example has the following additional requirements.

- NVIDIA toolkit.
- NVIDIA cuDNN library.
- NVIDIA TensorRT library.
- Environment variables for the compilers and libraries. For details, see “Third-Party Hardware” (GPU Coder) and “Setting Up the Prerequisite Products” (GPU Coder).

### Verify GPU Environment

To verify that the compilers and libraries for running this example are set up correctly, use the `coder.checkGpuInstall` (GPU Coder) function.

```
envCfg = coder.gpuEnvConfig('host');  
envCfg.DeepLibTarget = 'cudnn';  
envCfg.DeepCodegen = 1;  
envCfg.Quiet = 1;  
coder.checkGpuInstall(envCfg);
```

### Segmentation Network

SqueezeSegV2 is a convolutional neural network (CNN) designed for the semantic segmentation of organized lidar point clouds. It is a deep encoder-decoder segmentation network trained on a lidar data set and imported into MATLAB® for inference. In SqueezeSegV2, the encoder subnetwork consists of convolution layers that are interspersed with max-pooling layers. This arrangement successively decreases the resolution of the input image. The decoder subnetwork consists of a series of transposed convolution layers, which successively increase the resolution of the input image. In addition, the SqueezeSegV2 network mitigates the impact of missing data by including context aggregation modules (CAMs). A CAM is a convolutional subnetwork with `filterSize` of value [7, 7] that aggregates contextual information from a larger receptive field, which improves the robustness of the network to missing data. The SqueezeSegV2 network in this example is trained to segment points belonging to three classes (background, car, and truck).



For more information on training a semantic segmentation network in MATLAB® by using the Mathworks lidar dataset, see “Lidar Point Cloud Semantic Segmentation Using PointSeg Deep Learning Network” on page 1-128.

Download the pretrained SqueezeSegV2 Network.

```
net = getSqueezeSegV2Net();
```

Downloading pretrained SqueezeSegV2 (2 MB)...

The DAG network contains 238 layers, including convolution, ReLU, and batch normalization layers, and a focal loss output layer. To display an interactive visualization of the deep learning network architecture, use the `analyzeNetwork` (Deep Learning Toolbox) function.

```
analyzeNetwork(net);
```

### **squeezesegv2\_predict Entry-Point Function**

The `squeezesegv2_predict.m` entry-point function, which is attached to this example, takes a point cloud as input and performs prediction on it by using the deep learning network saved in the `SqueezeSegV2Net.mat` file. The function loads the network object from the `SqueezeSegV2Net.mat` file into a persistent variable `mynet` and reuses the persistent variable in subsequent prediction calls.

```
type('squeezesegv2_predict.m');
```

```
function out = squeezesegv2_predict(in)
%#codegen
```

```
% A persistent object mynet is used to load the DAG network object. At
% the first call to this function, the persistent object is constructed and
% setup. When the function is called subsequent times, the same object is
% reused to call predict on inputs, thus avoiding reconstructing and
% reloading the network object.
```

```
% Copyright 2020 The MathWorks, Inc.
```

```
persistent mynet;
```

```
if isempty(mynet)
    mynet = coder.loadDeepLearningNetwork('SqueezeSegV2Net.mat');
end
```

```
% pass in input
out = predict(mynet,in);
```

### **Generate CUDA MEX Code**

To generate CUDA MEX code for the `squeezesegv2_predict.m` entry-point function, create a GPU code configuration object for a MEX target and set the target language to C++. Use the `coder.DeepLearningConfig` (GPU Coder) function to create a CuDNN deep learning configuration object and assign it to the `DeepLearningConfig` property of the GPU code configuration object. Run the `codegen` command, specifying an input size of [64, 1024, 5]. This value corresponds to the size of the input layer of the SqueezeSegV2 network.

```
cfg = coder.gpuConfig('mex');
cfg.TargetLang = 'C++';
```

```
cfg.DeepLearningConfig = coder.DeepLearningConfig('cudnn');
codegen -config cfg squeezesegv2_predict -args {ones(64,1024,5,'uint8')} -report
```

Code generation successful: [View report](#)

To generate CUDA C++ code that takes advantage of NVIDIA TensorRT libraries, in the code, specify `coder.DeepLearningConfig('tensorrt')` instead of `coder.DeepLearningConfig('cudnn')`.

For information on how to generate MEX code for deep learning networks on Intel® processors, see “Code Generation for Deep Learning Networks with MKL-DNN” (MATLAB Coder).

## Prepare Data

Load an organized test point cloud in MATLAB®. Convert the point cloud to a five-channel image for prediction.

```
ptCloud = pcread('ousterLidarDrivingData.pcd');
I = pointCloudToImage(ptCloud);
```

```
% Examine converted data
whos I
```

Name	Size	Bytes	Class	Attributes
I	64x1024x5	327680	uint8	

The image has five channels. The  $(x,y,z)$  point coordinates comprise the first three channels. The fourth channel contains the lidar intensity measurement. The fifth channel contains the range information, which is computed as  $r = \sqrt{x^2 + y^2 + z^2}$ .

Visualize intensity channel of the image.

```
intensityChannel = I(:,:,4);

figure;
imshow(intensityChannel);
title('Intensity Image');
```



## Run Generated MEX on Data

Call `squeezesegv2_predict_mex` on the five-channel image.

```
predict_scores = squeezesegv2_predict_mex(I);
```

The `predict_scores` variable is a three-dimensional matrix that has three channels corresponding to the pixel-wise prediction scores for every class. Compute the channel by using the maximum prediction score to get the pixel-wise labels

```
[~,argmax] = max(predict_scores,[],3);
```

Overlay the segmented labels on the intensity channel image and display the segmented region. Resize the segmented output and add a colorbar for better visualization.

```

classes = [
    "background"
    "car"
    "truck"
];

cmap = lidarColorMap();
SegmentedImage = labeloverlay(intensityChannel, argmax, 'ColorMap', cmap);
SegmentedImage = imresize(SegmentedImage, 'Scale', [2 1], 'method', 'nearest');
figure;
imshow(SegmentedImage);

N = numel(classes);
ticks = 1/(N*2):1/N:1;
colorbar('TickLabels', cellstr(classes), 'Ticks', ticks, 'TickLength', 0, 'TickLabelInterpreter', 'none');
colormap(cmap);
title('Semantic Segmentation Result');

```



### Run Generated MEX Code on Point Cloud Sequence

Read an input point cloud sequence. The sequence contains 10 organized pointCloud frames collected using an Ouster OS1 lidar sensor. The input data has a height of 64 and a width of 1024, so each pointCloud object is of size 64-by-1024.

```
dataFile = 'highwaySceneData.mat';
```

```
% Load data in workspace.
load(dataFile);
```

Setup different colors to visualize point-wise labels for different classes of interest.

```
% Apply the color red to cars.
carClassColor = zeros(64, 1024, 3, 'uint8');
carClassColor(:,:,1) = 255*ones(64, 1024, 'uint8');
```

```
% Apply the color blue to trucks.
truckClassColor = zeros(64, 1024, 3, 'uint8');
truckClassColor(:,:,3) = 255*ones(64, 1024, 'uint8');
```

```
% Apply the color gray to background.
backgroundClassColor = 153*ones(64, 1024, 3, 'uint8');
```

Set the pcplayer function properties to display the sequence and the output predictions. Read the input sequence frame by frame and detect classes of interest using the model.

```
xlimits = [0 120.0];
ylimits = [-80.7 80.7];
zlimits = [-8.4 27];

player = pcplayer(xlimits, ylimits, zlimits);
set(get(player.Axes, 'parent'), 'units', 'normalized', 'outerposition', [0 0 1 1]);
zoom(get(player.Axes, 'parent'), 2);
set(player.Axes, 'XColor', 'none', 'YColor', 'none', 'ZColor', 'none');

for i = 1 : numel(inputData)
    ptCloud = inputData{i};

    % Convert point cloud to five-channel image for prediction.
    I = pointCloudToImage(ptCloud);

    % Call squeezesegv2_predict_mex on the 5-channel image.
    predict_scores = squeezesegv2_predict_mex(I);

    % Convert the numeric output values to categorical labels.
    [~, predictedOutput] = max(predict_scores, [], 3);
    predictedOutput = categorical(predictedOutput, 1:3, classes);

    % Extract the indices from labels.
    carIndices = predictedOutput == 'car';
    truckIndices = predictedOutput == 'truck';
    backgroundIndices = predictedOutput == 'background';

    % Extract a point cloud for each class.
    carPointCloud = select(ptCloud, carIndices, 'OutputSize', 'full');
    truckPointCloud = select(ptCloud, truckIndices, 'OutputSize', 'full');
    backgroundPointCloud = select(ptCloud, backgroundIndices, 'OutputSize', 'full');

    % Fill the colors to different classes.
    carPointCloud.Color = carClassColor;
    truckPointCloud.Color = truckClassColor;
    backgroundPointCloud.Color = backgroundClassColor;

    % Merge and add all the processed point clouds with class information.
    coloredCloud = pcmerge(carPointCloud, truckPointCloud, 0.01);
    coloredCloud = pcmerge(coloredCloud, backgroundPointCloud, 0.01);

    % View the output.
    view(player, coloredCloud);
    drawnow;
end
```

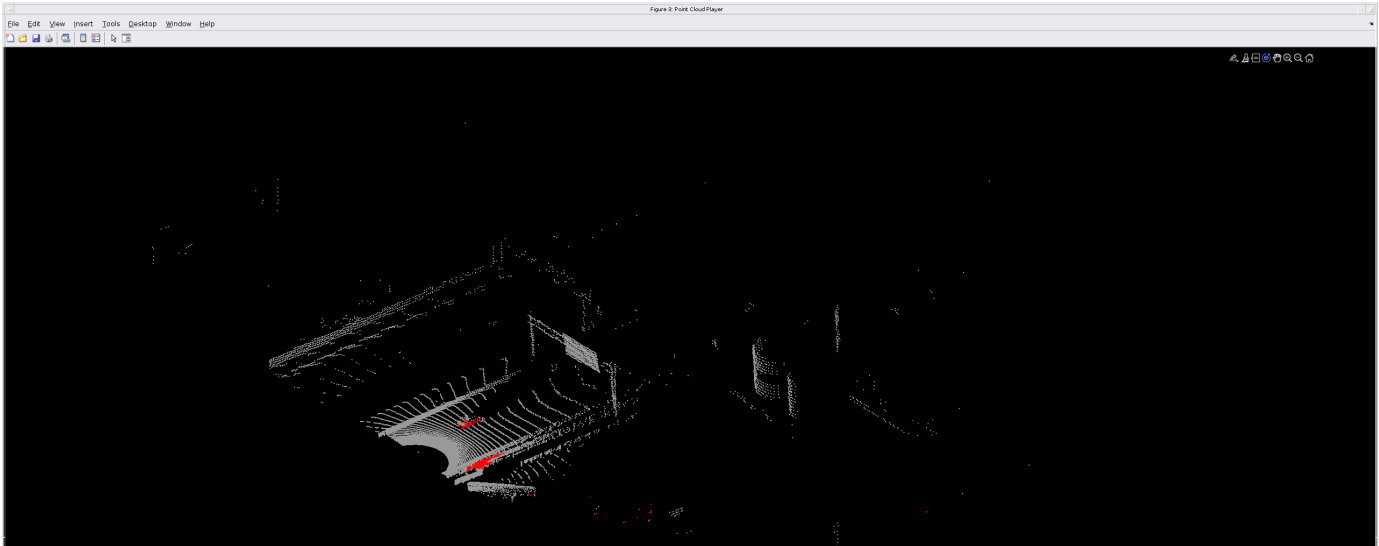

## Helper Functions

The helper functions used in this example follow.

type `pointCloudToImage.m`

```
function image = pointCloudToImage(ptcloud)
%pointCloudToImage Converts organized 3-D point cloud to 5-channel
% 2-D image.
```

```
image = ptcloud.Location;
image(:,:,4) = ptcloud.Intensity;
rangeData = iComputeRangeData(image(:,:,1),image(:,:,2),image(:,:,3));
image(:,:,5) = rangeData;
```

```
% Cast to uint8.
image = uint8(image);
end
```

```
%-----
function rangeData = iComputeRangeData(xChannel,yChannel,zChannel)
rangeData = sqrt(xChannel.*xChannel+yChannel.*yChannel+zChannel.*zChannel);
end
```

type `lidarColorMap.m`

```
function cmap = lidarColorMap()

cmap = [
    0.00 0.00 0.00 % background
    0.98 0.00 0.00 % car
    0.00 0.00 0.98 % truck
];
end
```

## References

[1] Wu, Bichen, Xuanyu Zhou, Sicheng Zhao, Xiangyu Yue, and Kurt Keutzer. "SqueezeSegV2: Improved Model Structure and Unsupervised Domain Adaptation for Road-Object Segmentation from a LiDAR Point Cloud." Preprint, submitted September 22, 2018. <http://arxiv.org/abs/1809.08495>.

# Lidar 3-D Object Detection Using PointPillars Deep Learning

This example shows how to train a PointPillars network for object detection in point clouds.

Lidar point cloud data can be acquired by a variety of lidar sensors, including Velodyne®, Pandar, and Ouster sensors. These sensors capture 3-D position information about objects in a scene, which is useful for many applications in autonomous driving and augmented reality. However, training robust detectors with point cloud data is challenging because of the sparsity of data per object, object occlusions, and sensor noise. Deep learning techniques have been shown to address many of these challenges by learning robust feature representations directly from point cloud data. One deep learning technique for 3-D object detection is PointPillars [1 on page 1-0]. Using a similar architecture to PointNet, the PointPillars network extracts dense, robust features from sparse point clouds called pillars, then uses a 2-D deep learning network with a modified SSD object detection network to estimate joint 3-D bounding boxes, orientations, and class predictions.

## Download Lidar Data Set

This example uses a subset of PandaSet [2 on page 1-0] that contains 2560 preprocessed organized point clouds. Each point cloud covers 360° of view, and is specified as a 64-by-1856 matrix. The point clouds are stored in PCD format and their corresponding ground truth data is stored in the `PandaSetLidarGroundTruth.mat` file. The file contains 3-D bounding box information for three classes, which are car, truck, and pedestrian. The size of the data set is 5.2 GB.

Download the Pandaset dataset from the given URL using the `helperDownloadPandasetData` helper function, defined at the end of this example.

```
doTraining = false;

outputFolder = fullfile(tempdir,'Pandaset');

lidarURL = ['https://ssd.mathworks.com/supportfiles/lidar/data/' ...
    'Pandaset_LidarData.tar.gz'];
helperDownloadPandasetData(outputFolder,lidarURL);
```

Depending on your Internet connection, the download process can take some time. The code suspends MATLAB® execution until the download process is complete. Alternatively, you can download the data set to your local disk using your web browser and extract the file. If you do so, change the `outputFolder` variable in the code to the location of the downloaded file. The downloaded file contains `Lidar`, `Cuboids` and `semanticLabels` folders that holds the point clouds, cuboid label and semantic label info respectively

## Load Data

Create a file datastore to load the PCD files from the specified path using the `pcread` function.

```
path = fullfile(outputFolder,'Lidar');
lidarData = fileDatastore(path,'ReadFcn',@(x) pcread(x));
```

Load the 3-D bounding box labels of the car and truck objects.

```
gtPath = fullfile(outputFolder,'Cuboids','PandaSetLidarGroundTruth.mat');
data = load(gtPath,'lidarGtLabels');
Labels = timetable2table(data.lidarGtLabels);
boxLabels = Labels(:,2:3);
```

Display the full-view point cloud.

```
figure
ptCld = read(lidarData);
ax = pcshow(ptCld.Location);
set(ax,'XLim',[-50 50],'YLim',[-40 40]);
zoom(ax,2.5);
axis off;
```

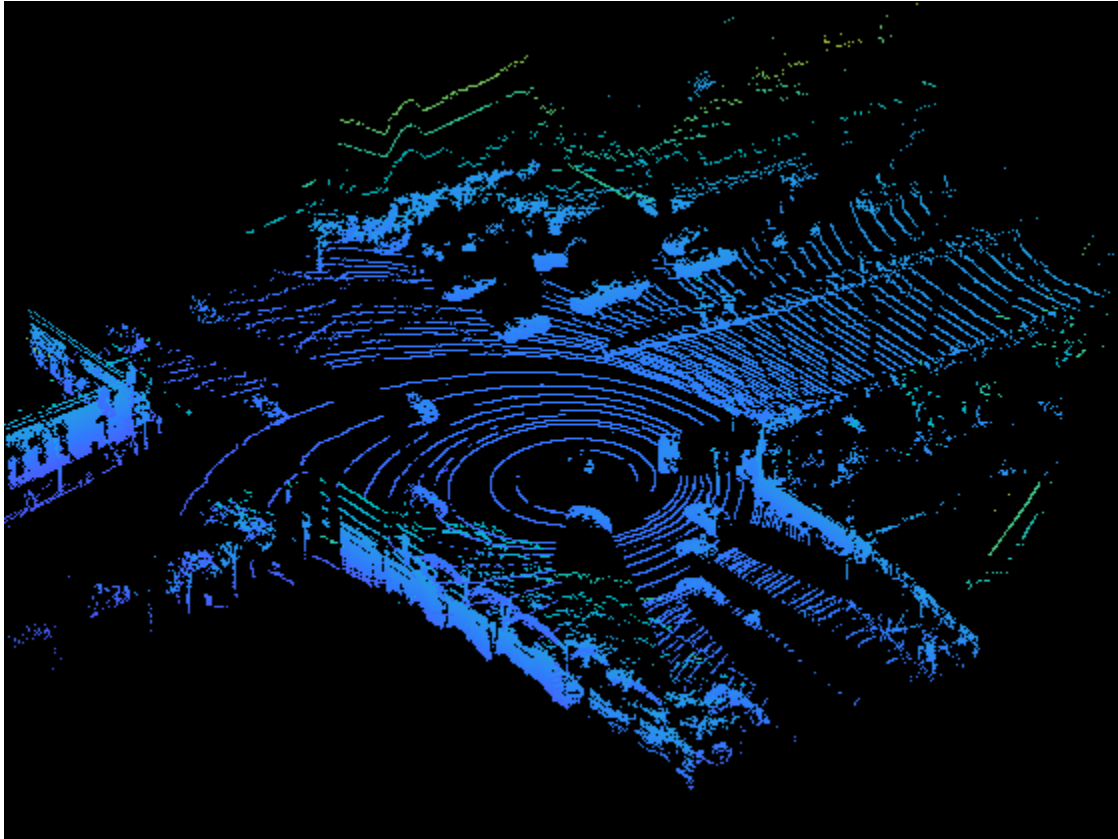

```
reset(lidarData);
```

### Preprocess Data

The PandaSet data consists of full-view point clouds. For this example, crop the full-view point clouds to front-view point clouds using the standard parameters [1 on page 1-0 ]. These parameters determine the size of the input passed to the network. Select a smaller point cloud range along the x, y, and z-axis to detect objects closer to origin. This also decreases the overall training time of the network.

```
xMin = 0.0;      % Minimum value along X-axis.
yMin = -39.68;  % Minimum value along Y-axis.
zMin = -5.0;    % Minimum value along Z-axis.
xMax = 69.12;   % Maximum value along X-axis.
yMax = 39.68;   % Maximum value along Y-axis.
zMax = 5.0;     % Maximum value along Z-axis.
xStep = 0.16;   % Resolution along X-axis.
yStep = 0.16;   % Resolution along Y-axis.
dsFactor = 2.0; % Downsampling factor.

% Calculate the dimensions for the pseudo-image.
```



```
Xn = round(((xMax - xMin)/xStep));
Yn = round(((yMax - yMin)/yStep));

% Define point cloud parameters.
pointCloudRange = [xMin xMax yMin yMax zMin zMax];
voxelSize = [xStep yStep];
```

Use the `cropFrontViewFromLidarData` helper function, attached to this example as a supporting file, to:

- Crop the front view from the input full-view point cloud.
- Select the box labels that are inside the ROI specified by `gridParams`.

```
[croppedPointCloudObj,processedLabels] = cropFrontViewFromLidarData(...
    lidarData,boxLabels,pointCloudRange);
```

```
Processing data 100% complete
```

Display the cropped point cloud and the ground truth box labels using the `helperDisplay3DBoxesOverlaidPointCloud` helper function defined at the end of the example.

```
pc = croppedPointCloudObj{1,1};
gtLabelsCar = processedLabels.Car{1};
gtLabelsTruck = processedLabels.Truck{1};

helperDisplay3DBoxesOverlaidPointCloud(pc.Location,gtLabelsCar,...
    'green',gtLabelsTruck,'magenta','Cropped Point Cloud');
```

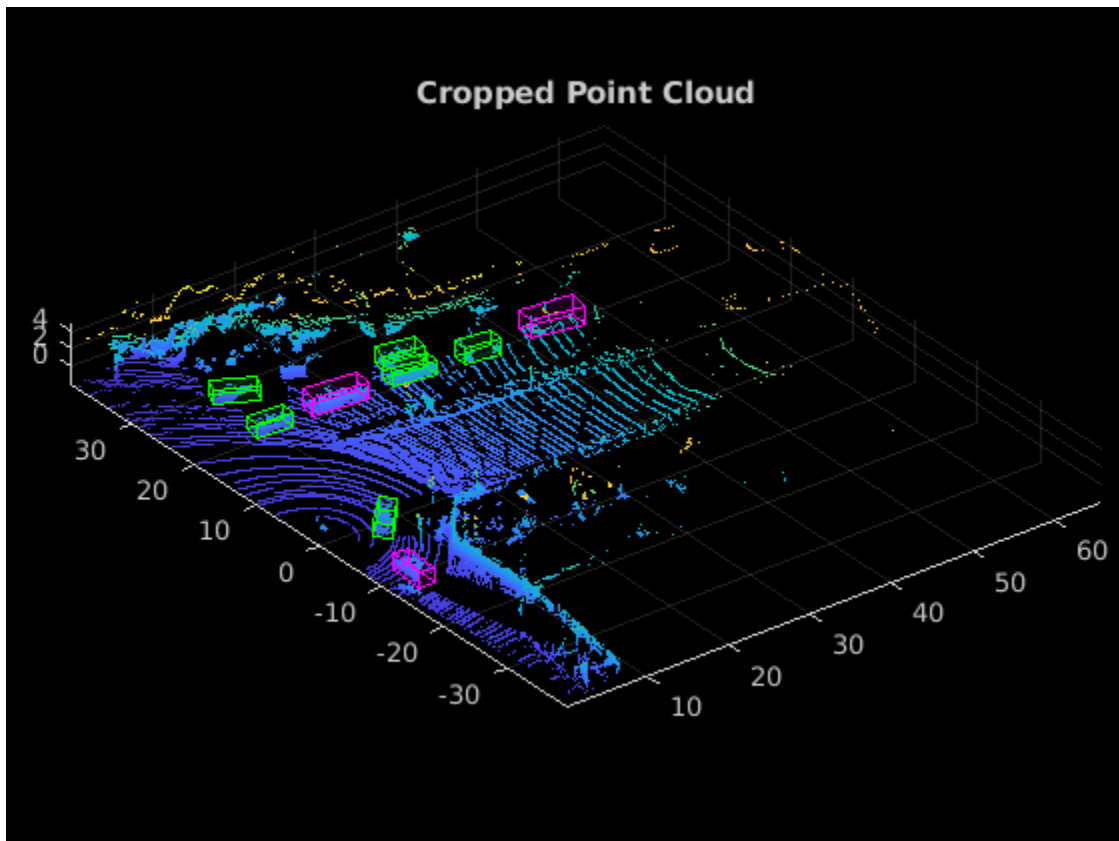

```
reset(lidarData);
```

### Create Datastore Objects for Training

Split the data set into training and test sets. Select 70% of the data for training the network and the rest for evaluation.

```
rng(1);
shuffledIndices = randperm(size(processedLabels,1));
idx = floor(0.7 * length(shuffledIndices));

trainData = croppedPointCloudObj(shuffledIndices(1:idx),:);
testData = croppedPointCloudObj(shuffledIndices(idx+1:end),:);

trainLabels = processedLabels(shuffledIndices(1:idx),:);
testLabels = processedLabels(shuffledIndices(idx+1:end),:);
```

So that you can easily access the datastores, save the training data as PCD files by using the `savePtCldToPCD` helper function, attached to this example as a supporting file. You can set `writeFiles` to "false" if your training data is saved in a folder and is supported by the `pcread` function.

```
writeFiles = true;
dataLocation = fullfile(outputFolder, 'InputData');
[trainData,trainLabels] = savePtCldToPCD(trainData,trainLabels,...
    dataLocation,writeFiles);
```

```
Processing data 100% complete
```

Create a file datastore using `fileDatastore` to load PCD files using the `pcread` function.

```
lds = fileDatastore(dataLocation, 'ReadFcn', @(x) pcread(x));
```

Create a box label datastore using `boxLabelDatastore` for loading the 3-D bounding box labels.

```
bds = boxLabelDatastore(trainLabels);
```

Use the `combine` function to combine the point clouds and 3-D bounding box labels into a single datastore for training.

```
cds = combine(lds,bds);
```

### Data Augmentation

This example uses ground truth data augmentation and several other global data augmentation techniques to add more variety to the training data and corresponding boxes. For more information on typical data augmentation techniques used in 3-D object detection workflows with lidar data, see the "Data Augmentations for Lidar Object Detection Using Deep Learning" on page 1-255.

Read and display a point cloud before augmentation using the `helperDisplay3DBoxesOverlaidPointCloud` helper function, defined at the end of the example..

```
augData = read(cds);
augPtCld = augData{1,1};
augLabels = augData{1,2};
augClass = augData{1,3};

labelsCar = augLabels(augClass=='Car',:);
```

```

labelsTruck = augLabels(augClass=='Truck',:);
helperDisplay3DBoxesOverlaidPointCloud(augptCld.Location,labelsCar,'green',...
    labelsTruck,'magenta','Before Data Augmentation');

```

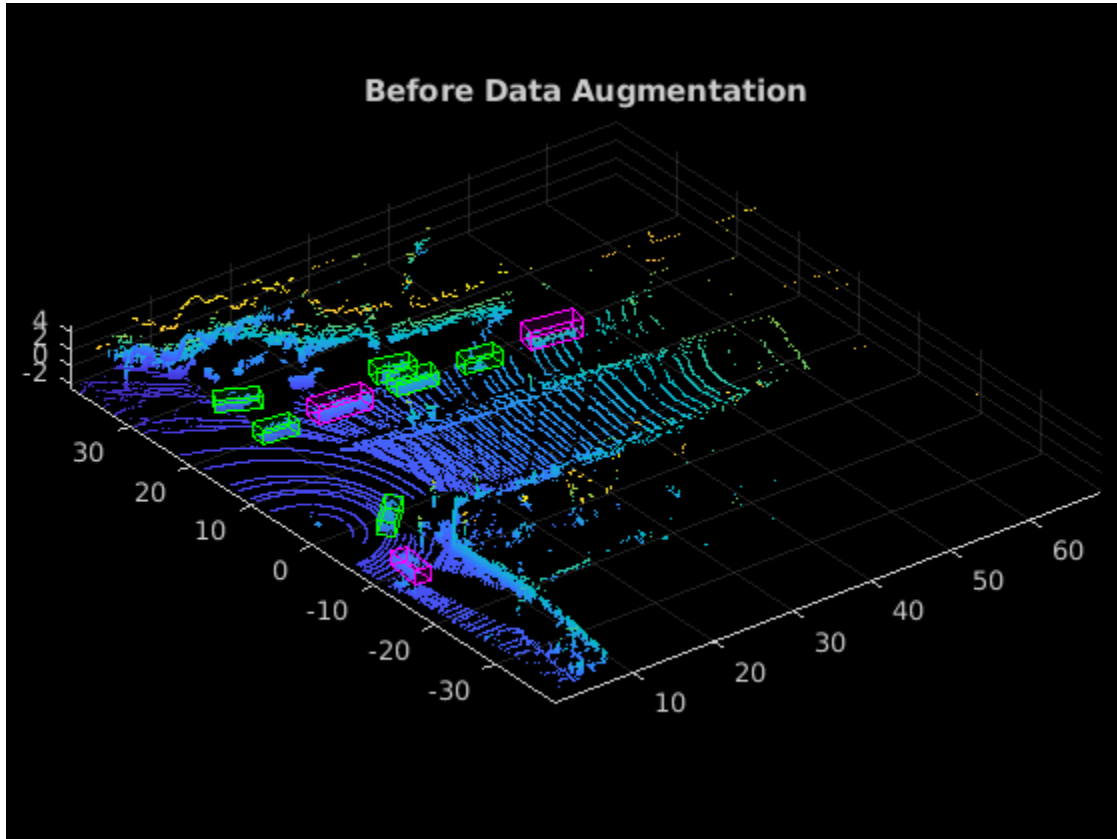

```
reset(cds);
```

Use the `sampleLidarData` function to sample 3-D bounding boxes and their corresponding points from the training data.

```

classNames = {'Car','Truck'};
sampleLocation = fullfile(outputFolder,'GTsamples');
[lDsSampled,bDsSampled] = sampleLidarData(cds,classNames,'MinPoints',20,...
    'Verbose',false,'WriteLocation',sampleLocation);
cdsSampled = combine(lDsSampled,bDsSampled);

```

Use the `pcBboxOversample` function to randomly add a fixed number of car and truck class objects to every point cloud. Use the `transform` function to apply the ground truth and custom data augmentations to the training data.

```

numObjects = [10 10];
cdsAugmented = transform(cds,@(x)pcBboxOversample(x,cdsSampled,classNames,numObjects));

```

Apply these additional data augmentation techniques to every point cloud.

- Random flipping along the x-axis
- Random scaling by 5 percent

- Random rotation along the z-axis from  $[-\pi/4, \pi/4]$
- Random translation by  $[0.2, 0.2, 0.1]$  meters along the x-, y-, and z-axis respectively

```
cdsAugmented = transform(cdsAugmented,@(x)augmentData(x));
```

Display an augmented point cloud along with the ground truth augmented boxes using the `helperDisplay3DBoxesOverlaidPointCloud` helper function, defined at the end of the example.

```
augData = read(cdsAugmented);  
augptCld = augData{1,1};  
augLabels = augData{1,2};  
augClass = augData{1,3};  
  
labelsCar = augLabels(augClass=='Car',:);  
labelsTruck = augLabels(augClass=='Truck',:);  
  
helperDisplay3DBoxesOverlaidPointCloud(augptCld.Location,labelsCar,'green',...  
    labelsTruck,'magenta','After Data Augmentation');
```

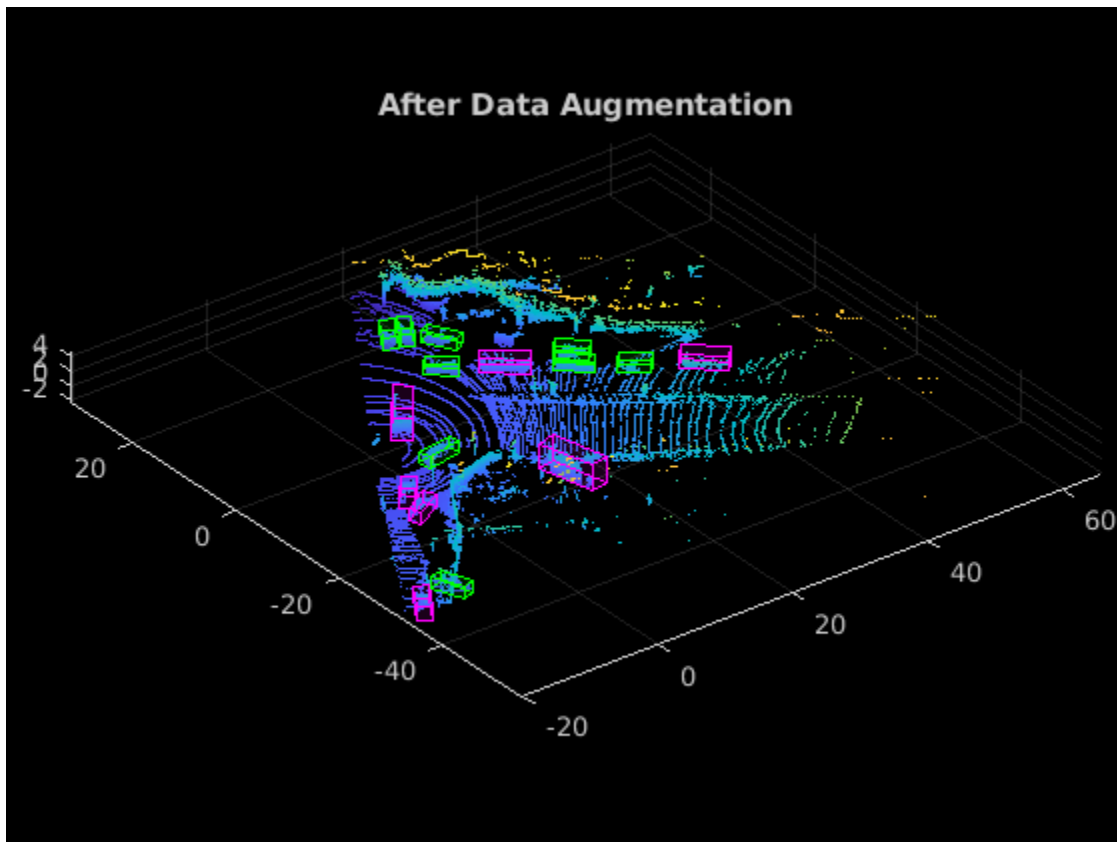

```
reset(cdsAugmented);
```

### Create PointPillars Object Detector

Use the `pointPillarsObjectDetector` function to create a PointPillars object detection network. For more information on PointPillars network, see “Getting Started with PointPillars” on page 4-49.

The diagram shows the network architecture of a PointPillars object detector. You can use the Deep Network Designer (Deep Learning Toolbox) App to create a PointPillars network.

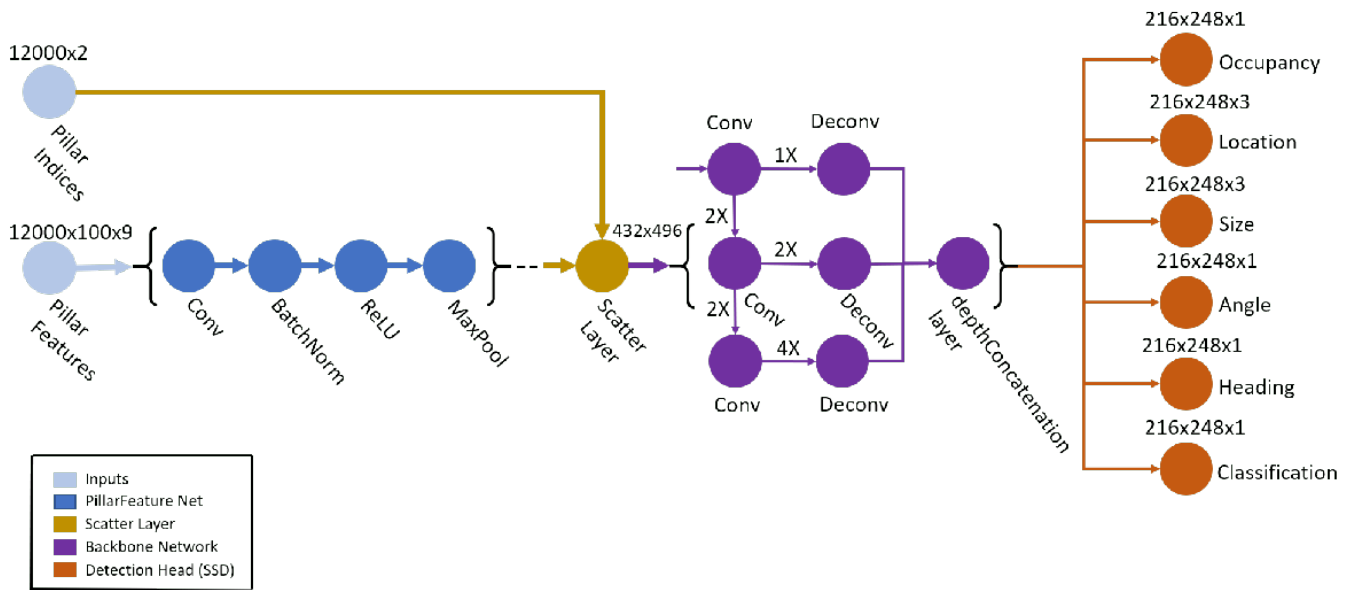

The `pointPillarsObjectDetector` function requires you to specify several inputs that parameterize the PointPillars network:

- Class names
- Anchor boxes
- Point cloud range
- Voxel size
- Number of prominent pillars
- Number of points per pillar

```
% Define the number of prominent pillars.
P = 12000;
```

```
% Define the number of points per pillar.
N = 100;
```

Estimate the anchor boxes from training data using `calculateAnchorsPointPillars` helper function, attached to this example as a supporting file.

```
anchorBoxes = calculateAnchorsPointPillars(trainLabels);
classNames = trainLabels.Properties.VariableNames;
```

Define the PointPillars detector.

```
detector = pointPillarsObjectDetector(pointCloudRange,classNames,anchorBoxes,...
    'VoxelSize',voxelSize,'NumPillars',P,'NumPointsPerPillar',N);
```

### Train Pointpillars Object Detector

Specify the network training parameters using the `trainingOptions` (Deep Learning Toolbox) function. Set `'CheckpointPath'` to a temporary location to enable saving of partially trained detectors during the training process. If training is interrupted, you can resume training from the saved checkpoint.

Train the detector using a CPU or GPU. Using a GPU requires Parallel Computing Toolbox™ and a CUDA® enabled NVIDIA® GPU. For more information, see “GPU Support by Release” (Parallel Computing Toolbox). To automatically detect if you have a GPU available, set `executionEnvironment` to "auto". If you do not have a GPU, or do not want to use one for training, set `executionEnvironment` to "cpu". To ensure the use of a GPU for training, set `executionEnvironment` to "gpu".

```
executionEnvironment = "auto";
if canUseParallelPool
    dispatchInBackground = true;
else
    dispatchInBackground = false;
end

options = trainingOptions('adam',...
    'Plots','none',...
    'MaxEpochs',60,...
    'MiniBatchSize',3,...
    'GradientDecayFactor',0.9,...
    'SquaredGradientDecayFactor',0.999,...
    'LearnRateSchedule','piecewise',...
    'InitialLearnRate',0.0002,...
    'LearnRateDropPeriod',15,...
    'LearnRateDropFactor',0.8,...
    'ExecutionEnvironment',executionEnvironment,...
    'DispatchInBackground',dispatchInBackground,...
    'BatchNormalizationStatistics','moving',...
    'ResetInputNormalization',false,...
    'CheckpointPath',tempdir);
```

Use the `trainPointPillarsObjectDetector` function to train the PointPillars object detector if `doTraining` is "true". Otherwise, load a pretrained detector.

```
if doTraining
    [detector,info] = trainPointPillarsObjectDetector(cdsAugmented,detector,options);
else
    pretrainedDetector = load('pretrainedPointPillarsDetector.mat','detector');
    detector = pretrainedDetector.detector;
end
```

### Generate Detections

Use the trained network to detect objects in the test data:

- Read the point cloud from the test data.
- Run the detector on the test point cloud to get the predicted bounding boxes and confidence scores.
- Display the point cloud with bounding boxes using the `helperDisplay3DBoxesOverlaidPointCloud` helper function, defined at the end of the example.

```
ptCloud = testData{45,1};
gtLabels = testLabels(45,:);
```

```
% Specify the confidence threshold to use only detections with
% confidence scores above this value.
```

```

confidenceThreshold = 0.5;
[box,score,labels] = detect(detector,ptCloud,'Threshold',confidenceThreshold);

boxlabelsCar = box(labels=='Car',:);
boxlabelsTruck = box(labels=='Truck',:);

% Display the predictions on the point cloud.
helperDisplay3DBoxesOverlaidPointCloud(ptCloud.Location,boxlabelsCar,'green',...
    boxlabelsTruck,'magenta','Predicted Bounding Boxes');

```

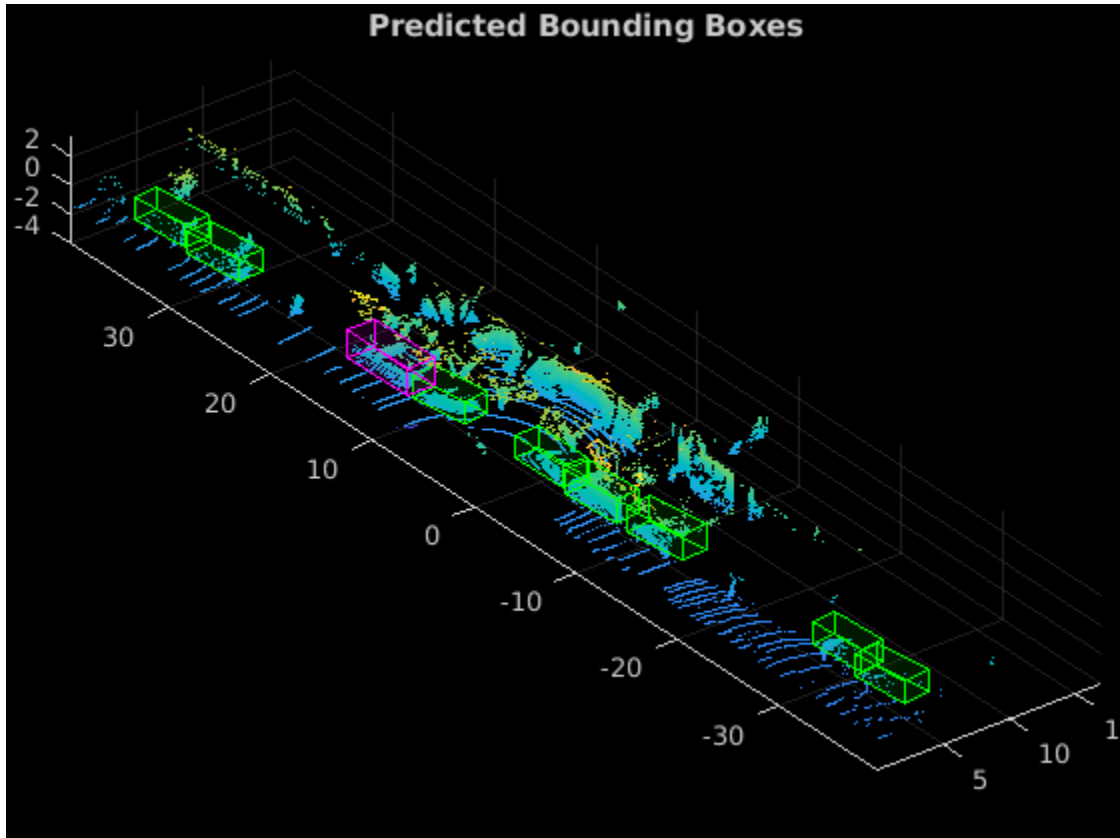

### Evaluate Detector Using Test Set

Evaluate the trained object detector on a large set of point cloud data to measure the performance.

```

numInputs = 50;

% Generate rotated rectangles from the cuboid labels.
bds = boxLabelDatastore(testLabels(1:numInputs,:));
groundTruthData = transform(bds,@(x)createRotRect(x));

% Set the threshold values.
nmsPositiveIoUThreshold = 0.5;
confidenceThreshold = 0.25;

detectionResults = detect(detector,testData(1:numInputs,:),...
    'Threshold',confidenceThreshold);

% Convert the bounding boxes to rotated rectangles format and calculate

```

```

% the evaluation metrics.
for i = 1:height(detectionResults)
    box = detectionResults.Boxes{i};
    detectionResults.Boxes{i} = box(:, [1,2,4,5,7]);
end

metrics = evaluateDetectionAOS(detectionResults,groundTruthData,...
    nmsPositiveIoUThreshold);
disp(metrics(:,1:2))

```

	AOS	AP
Car	0.89666	0.89666
Truck	0.76047	0.76047

### Helper Functions

```

function helperDownloadPandasetData(outputFolder,lidarURL)
% Download the data set from the given URL to the output folder.

    lidarDataTarFile = fullfile(outputFolder,'Pandaset_LidarData.tar.gz');

    if ~exist(lidarDataTarFile,'file')
        mkdir(outputFolder);

        disp('Downloading PandaSet Lidar driving data (5.2 GB)...');
        websave(lidarDataTarFile,lidarURL);
        untar(lidarDataTarFile,outputFolder);
    end

    % Extract the file.
    if (~exist(fullfile(outputFolder,'Lidar'),'dir'))...
        &&(~exist(fullfile(outputFolder,'Cuboids'),'dir'))
        untar(lidarDataTarFile,outputFolder);
    end

end

function helperDisplay3DBboxesOverlaidPointCloud(ptCld,labelsCar,carColor,...
    labelsTruck,truckColor,titleForFigure)
% Display the point cloud with different colored bounding boxes for different
% classes.
    figure;
    ax = pcshow(ptCld);
    showShape('cuboid',labelsCar,'Parent',ax,'Opacity',0.1,...
        'Color',carColor,'LineWidth',0.5);
    hold on;
    showShape('cuboid',labelsTruck,'Parent',ax,'Opacity',0.1,...
        'Color',truckColor,'LineWidth',0.5);
    title(titleForFigure);
    zoom(ax,1.5);
end

```

### References

[1] Lang, Alex H., Sourabh Vora, Holger Caesar, Lubing Zhou, Jiong Yang, and Oscar Beijbom. "PointPillars: Fast Encoders for Object Detection From Point Clouds." In *2019 IEEE/CVF Conference*



on *Computer Vision and Pattern Recognition (CVPR)*, 12689-12697. Long Beach, CA, USA: IEEE, 2019. <https://doi.org/10.1109/CVPR.2019.01298>.

[2] Hesai and Scale. PandaSet. <https://scale.com/open-datasets/pandaset>.

## Aerial Lidar SLAM Using FPFH Descriptors

This example demonstrates how to implement the simultaneous localization and mapping (SLAM) algorithm for aerial mapping using 3-D features. The goal of this example is to estimate the trajectory of a robot and create a point cloud map of its environment.

The SLAM algorithm in this example estimates a trajectory by finding a coarse alignment between downsampled accepted scans, using fast point feature histogram (FPFH) descriptors extracted at each point, then applies the iterative closest point (ICP) algorithm to fine-tune the alignment. 3-D pose graph optimization, from Navigation Toolbox™, reduces the drift in the estimated trajectory.

### Create and Visualize Data

Create synthetic lidar scans from a patch of aerial data, downloaded from the OpenTopography website [1] on page 1-0 . Load a MAT-file containing a sequence of waypoints over aerial data that defines the trajectory of a robot. Compute lidar scans from the data at each waypoint using the `helperCreateDataset` function. The function outputs the lidar scans computed at each waypoint as an array of `pointCloud` objects, original map covered by robot and ground truth waypoints.

```
datafile = 'aerialMap.tar.gz';  
wayPointsfile = 'gTruthWayPoints.mat';  
  
% Generate a lidar scan at each waypoint using the helper function  
[pClouds,orgMap,gTruthWayPts] = helperCreateDataset(datafile,wayPointsfile);
```

Visualize the ground truth waypoints on the original map covered by the robot.

```
% Create a figure window to visualize the ground truth map and waypoints  
hFigGT = figure;  
axGT = axes('Parent',hFigGT,'Color','black');  
  
% Visualize the ground truth waypoints  
pcshow(gTruthWayPts,'red','MarkerSize',150,'Parent',axGT)  
hold on  
  
% Visualize the original map covered by the robot  
pcshow(orgMap,'MarkerSize',10,'Parent',axGT)  
hold off  
  
% Customize the axis labels  
xlabel(axGT,'X (m)')  
ylabel(axGT,'Y (m)')  
zlabel(axGT,'Z (m)')  
title(axGT,'Ground Truth Map And Robot Trajectory')
```

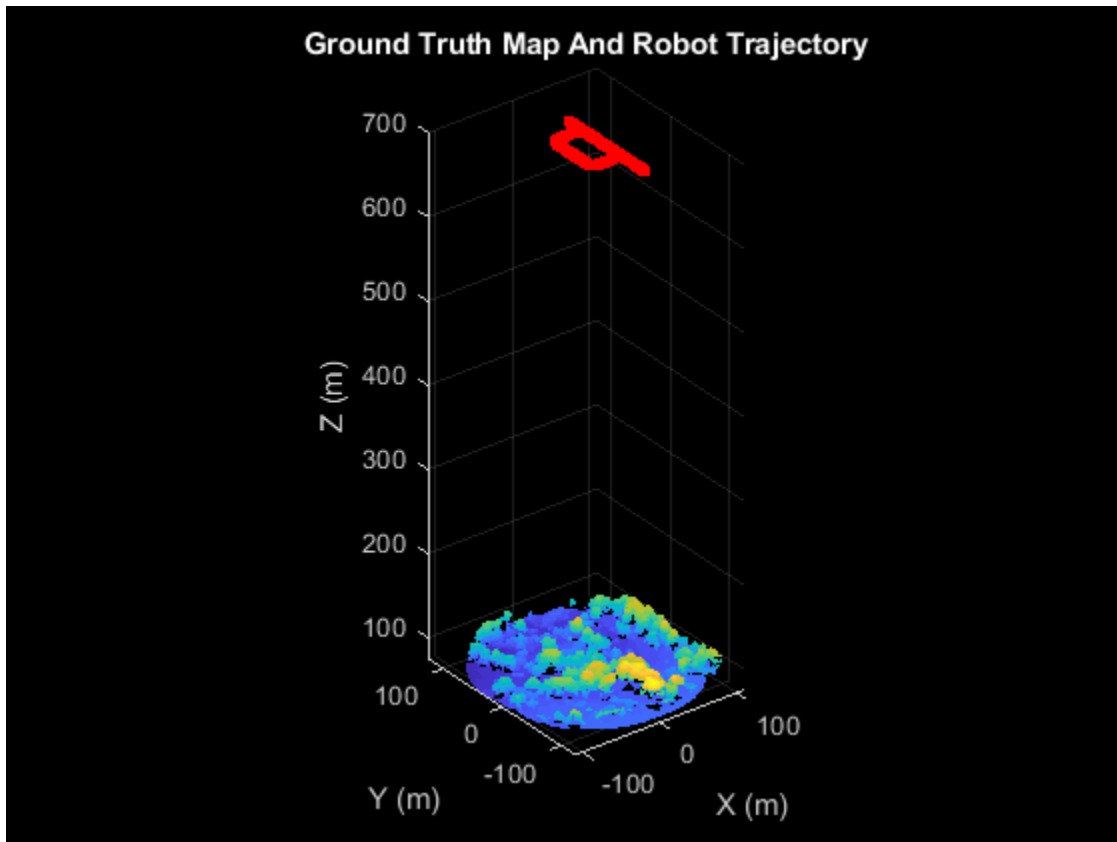

Visualize the extracted lidar scans using the `pcplayer` object.

```
% Specify limits for the player
xlims = [-90 90];
ylims = [-90 90];
zlims = [-625 -587];

% Create a pcplayer object to visualize the lidar scans
lidarPlayer = pcplayer(xlims,ylims,zlims);

% Customize the pcplayer axis labels
xlabel(lidarPlayer.Axes,'X (m)')
ylabel(lidarPlayer.Axes,'Y (m)')
zlabel(lidarPlayer.Axes,'Z (m)')
title(lidarPlayer.Axes,'Lidar Scans')

% Loop over and visualize the data
for l = 1:length(pClouds)

    % Extract the lidar scan
    ptCloud = pClouds(l);

    % Update the lidar display
    view(lidarPlayer,ptCloud)
    pause(0.05)
end
```

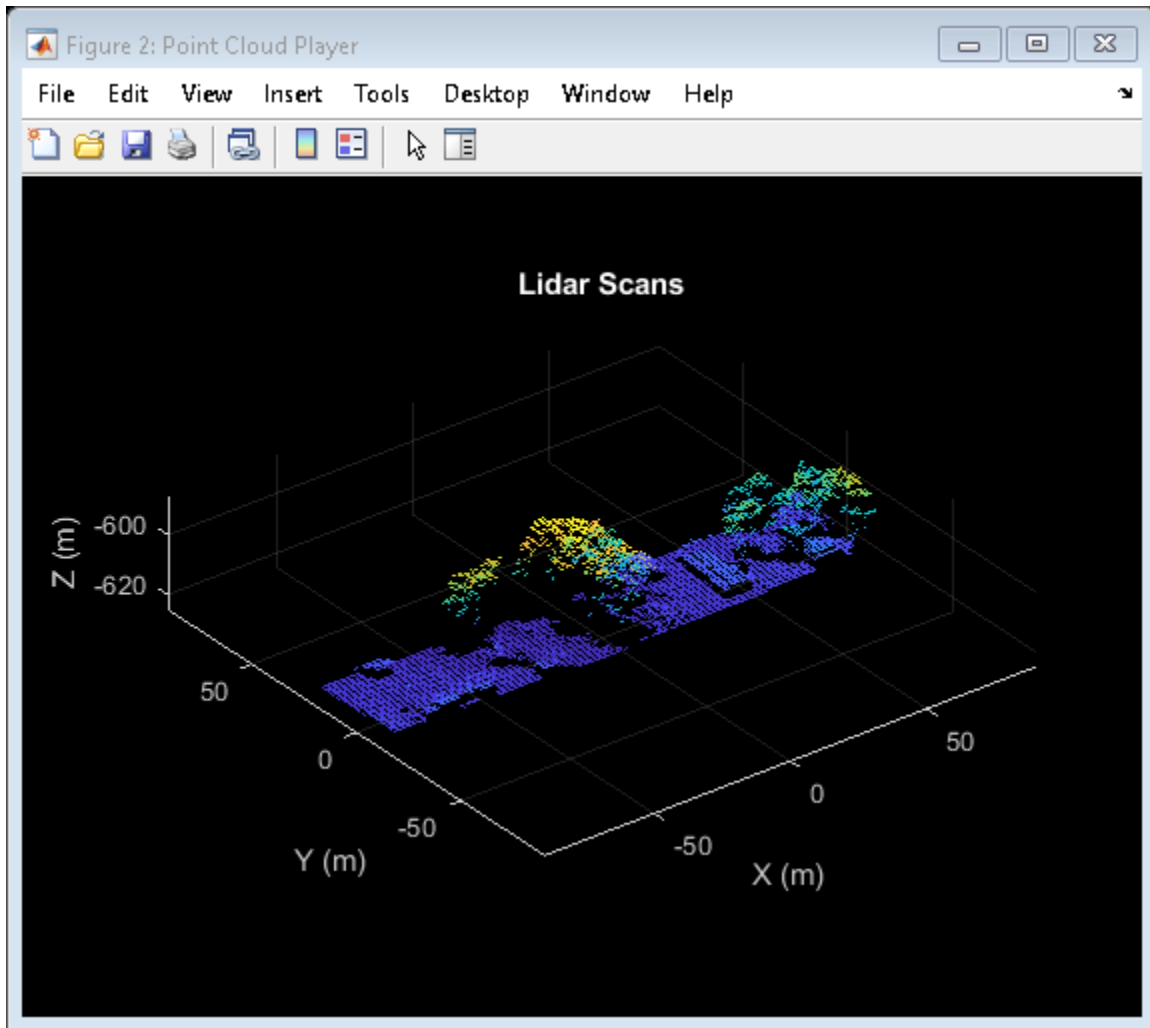

### Set Up Tunable Parameters

Specify the parameters for trajectory and loop closure estimation. Tune these parameters for your specific robot and environment.

### Parameters for Point Cloud Registration

Specify the number of lidar scans to skip between each scan accepted for registration. Since successive scans have high overlap, skipping a few frames can improve algorithm speed without compromising accuracy.

```
skipFrames = 3;
```

Downsampling lidar scans can improve algorithm speed. The box grid filter downsamples the point cloud by averaging all points within each cell to a single point. Specify the size for individual cells of a box grid filter, in meters.

```
gridStep = 1.5; % in meters
```

FPFH descriptors are extracted for each valid point in the downsampled point cloud. Specify the neighborhood size for the k-nearest neighbor (KNN) search method used to compute the descriptors.

```
neighbors = 60;
```

Set the threshold and ratio for matching the FPFH descriptors, used to identify point correspondences.

```
matchThreshold = 0.1;
matchRatio = 0.97;
```

Set the maximum distance and number of trails for relative pose estimation between successive scans.

```
maxDistance = 1;
maxNumTrails = 3000;
```

Specify the percentage of inliers to consider for fine-tuning relative poses.

```
inlierRatio = 0.1;
```

Specify the size of each cell of a box grid filter, used to create maps by aligning lidar scans.

```
alignGridStep = 1.2;
```

### Parameters for Loop Closure Estimation

Specify the radius around the current robot location to search for loop closure candidates.

```
loopClosureSearchRadius = 7.9;
```

The loop closure algorithm is based on 3-D submap creation and matching. A submap consists of a specified number of accepted scans `nScansPerSubmap`. The loop closure algorithm also disregards a specified number of the most recent scans `subMapThresh`, while searching for loop candidates.

Specify the root mean squared error (RMSE) threshold `loopClosureThreshold`, for accepting a submap as a match. A lower score can indicate a better match, but scores vary based on sensor data and preprocessing.

```
nScansPerSubmap = 3;
subMapThresh = 15;
loopClosureThreshold = 0.6;
```

Specify the maximum acceptable root mean squared error (RMSE) for the estimation of relative pose between loop candidates `rmseThreshold`. Choosing a lower value can result in more accurate loop closure edges, which has a high impact on pose graph optimization, but scores vary based on sensor data and preprocessing.

```
rmseThreshold = 0.6;
```

### Initialize Variables

Create a pose graph, using a `poseGraph3D` (Navigation Toolbox) object, to store estimated relative poses between accepted lidar scans.

```
pGraph = poseGraph3D;
```

```
% Default serialized upper-right triangle of a 6-by-6 Information Matrix
infoMat = [1 0 0 0 0 0 1 0 0 0 0 1 0 0 0 1 0 0 1 0 1];
```

Preallocate and initialize the variables required for computation.

```
% Allocate memory to store submaps
subMaps = cell(floor(length(pClouds)/(skipFrames*nScansPerSubmap)),1);

% Allocate memory to store each submap pose
subMapPoses = zeros(round(length(pClouds)/(skipFrames*nScansPerSubmap)),3);

% Initialize variables to store accepted scans and their transforms for
% submap creation
pcAccepted = pointCloud.empty(0);
tformAccepted = rigid3d.empty(0);

% Initialize variable to store relative poses from the feature-based approach
% without pose graph optimization
fpfhTform = rigid3d.empty(0);

% Counter to track the number of scans added
count = 1;
```

Create variables to visualize processed lidar scans and estimated trajectory.

```
% Set to 1 to visualize processed lidar scans during build process
viewPC = 0;
```

```
% Create a pcplayer object to view the lidar scans while
% processing them sequentially, if viewPC is enabled
```

```
if viewPC == 1
    pplayer = pcplayer(xlimits,ylimits,zlimits);
```

```
    % Customize player axis labels
    xlabel(pplayer.Axes,'X (m)')
    ylabel(pplayer.Axes,'Y (m)')
    zlabel(pplayer.Axes,'Z (m)')
    title(pplayer.Axes,'Processed Scans')
```

```
end
```

```
% Create a figure window to visualize the estimated trajectory
hFigTrajUpdate = figure;
axTrajUpdate = axes('Parent',hFigTrajUpdate,'Color','black');
title(axTrajUpdate,'Sensor Pose Trajectory')
```

## Trajectory Estimation and Refinement

The trajectory of the robot is a collection of its poses which consists of its location and orientation in 3-D space. Estimate a robot pose from a 3-D lidar scan instance using the 3-D lidar SLAM algorithm. Use these processes to perform 3-D SLAM estimation:

- 1 Point cloud downsampling
- 2 Point cloud registration
- 3 Submap creation
- 4 Loop closure querying
- 5 Pose graph optimization

Iteratively process the lidar scans to estimate the trajectory of the robot.

```
rng('default') % Set random seed to guarantee consistent results in pmatchfeatures
for FrameIdx = 1:skipFrames:length(pClouds)
```

## Point Cloud Downsampling

Point cloud downsampling can improve the speed of the point cloud registration algorithm. Downsampling should be tuned for your specific needs.

```
% Downsample the current scan
curScan = pcdownsample(pClouds(FrameIdx), 'gridAverage', gridStep);
if viewPC == 1

    % Visualize down sampled point cloud
    view(pplayer, curScan)
end
```

## Point Cloud Registration

Point cloud registration estimates the relative pose between the current scan and a previous scan. The example uses these steps for registration:

- 1 Extracts FPFH descriptors from each scan using the `extractFPFHFeatures` function
- 2 Identifies point correspondences by comparing descriptors using the `pcmatchfeatures` function
- 3 Estimates the relative pose from point correspondences using the `estimateGeometricTransform3D` function
- 4 Fine-tunes the relative pose using the `pcregistericp` function

```
% Extract FPFH features
curFeature = extractFPFHFeatures(curScan, 'NumNeighbors', neighbors);

if FrameIdx == 1

    % Update the acceptance scan and its tform
    pcAccepted(count,1) = curScan;
    tformAccepted(count,1) = rigid3d;

    % Update the initial pose to the first waypoint of ground truth for
    % comparison
    fpfhTform(count,1) = rigid3d(eye(3), gTruthWayPts(1,:));
else

    % Identify correspondences by matching current scan to previous scan
    indexPairs = pcmatchfeatures(curFeature, prevFeature, curScan, prevScan, ...
        'MatchThreshold', matchThreshold, 'RejectRatio', matchRatio);
    matchedPrevPts = select(prevScan, indexPairs(:,2));
    matchedCurPts = select(curScan, indexPairs(:,1));

    % Estimate relative pose between current scan and previous scan
    % using correspondences
    tform1 = estimateGeometricTransform3D(matchedCurPts.Location, ...
        matchedPrevPts.Location, 'rigid', 'MaxDistance', maxDistance, ...
        'MaxNumTrials', maxNumTrials);

    % Perform ICP registration to fine-tune relative pose
    tform = pcregistericp(curScan, prevScan, 'InitialTransform', tform1, ...
        'InlierRatio', inlierRatio);
```

Convert the rigid transformation to an xyz-position and a quaternion orientation to add it to the pose graph.

```

relPose = [tform2trvec(tform.T') tform2quat(tform.T')];

% Add relative pose to pose graph
addRelativePose(pGraph, relPose);

```

Store the accepted scans and their poses for submap creation.

```

% Update counter and store accepted scans and their poses
count = count + 1;
pcAccepted(count,1) = curScan;
accumPose = pGraph.nodes(height(pGraph.nodes));
tformAccepted(count,1) = rigid3d((trvec2tform(accumPose(1:3)) * ...
    quat2tform(accumPose(4:7)))');

% Update estimated poses
fpfhTform(count) = rigid3d(tform.T * fpfhTform(count-1).T);
end

```

### Submap Creation

Create submaps by aligning sequential, accepted scans with each other in groups of the specified size `nScansPerSubmap`, using the `pcaalign` function. Using submaps can result in faster loop closure queries.

```

currSubMapId = floor(count/nScansPerSubmap);
if rem(count,nScansPerSubmap) == 0

    % Align an array of lidar scans to create a submap
    subMaps{currSubMapId} = pcaalign(...
        pcAccepted((count - nScansPerSubmap + 1):count,1), ...
        tformAccepted((count - nScansPerSubmap + 1):count,1), ...
        alignGridStep);

    % Assign center scan pose as pose of submap
    subMapPoses(currSubMapId,:) = tformAccepted(count - ...
        floor(nScansPerSubmap/2),1).Translation;
end

```

### Loop Closure Query

Use a *loop closure query* to identify previously visited places. A loop closure query consists of finding a similarity between the current scan and previous submaps. If you find a similar scan, then the current scan is a loop closure candidate. Loop closure candidate estimation consists of these steps:

- 1 Estimate matches between previous submaps and the current scan using the `helperEstimateLoopCandidates` function. A submap is a match, if the RMSE between the current scan and submap is less than the specified value of `loopClosureThreshold`. The previous scans represented by all matching submaps are loop closure candidates.
- 2 Compute the relative pose between the current scan and the loop closure candidate using the ICP registration algorithm. The loop closure candidate with the lowest RMSE is the best probable match for the current scan.

A loop closure candidate is accepted as a valid loop closure only when the RMSE is lower than the specified threshold.

```

if currSubMapId > subMapThresh
    mostRecentScanCenter = pGraph.nodes(height(pGraph.nodes));

```



```

% Estimate possible loop closure candidates by matching current
% scan with submaps
[loopSubmapIds,~] = helperEstimateLoopCandidates(subMaps,curScan, ...
    subMapPoses,mostRecentScanCenter,currSubMapId,subMapThresh, ...
    loopClosureSearchRadius,loopClosureThreshold);

if ~isempty(loopSubmapIds)
    rmseMin = inf;

    % Estimate the best match for the current scan from the matching submap ids
    for k = 1:length(loopSubmapIds)

        % Check every scan within the submap
        for kf = 1:nScansPerSubmap
            probableLoopCandidate = ...
                loopSubmapIds(k)*nScansPerSubmap - kf + 1;
            [pose_Tform,~,rmse] = pregistericp(curScan, ...
                pCAccepted(probableLoopCandidate));

            % Update the best loop closure candidate
            if rmse < rmseMin
                rmseMin = rmse;
                matchingNode = probableLoopCandidate;
                Pose = [tform2trvec(pose_Tform.T') ...
                    tform2quat(pose_Tform.T')];
            end
        end
    end

    % Check if loop closure candidate is valid
    if rmseMin < rmseThreshold

        % Add relative pose of loop closure candidate to pose graph
        addRelativePose(pGraph,Pose,infoMat,matchingNode, ...
            pGraph.NumNodes);
    end
end

% Update previous point cloud and feature
prevScan = curScan;
prevFeature = curFeature;

% Visualize the estimated trajectory from the accepted scan.
show(pGraph,'IDs','off','Parent',axTrajUpdate);
drawnow
end

```

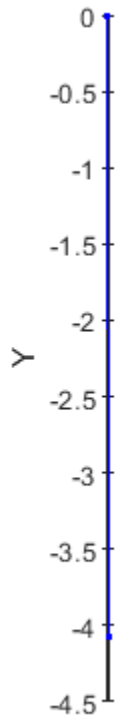

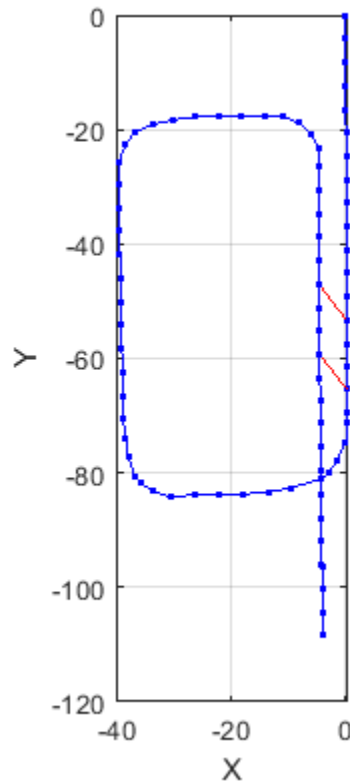

### Pose Graph Optimization

Reduce the drift in the estimated trajectory by using the `optimizePoseGraph` (Navigation Toolbox) function. In general, the pose of the first node in the pose graph represents the origin. To compare the estimated trajectory with the ground truth waypoints, specify the first ground truth waypoint as the pose of the first node.

```
pGraph = optimizePoseGraph(pGraph, 'FirstNodePose', [gTruthWayPts(1,:) 1 0 0 0]);
```

### Visualize Trajectory Comparisons

Visualize the estimated trajectory using the features without pose graph optimization, the features with pose graph optimization, and the ground truth data.

```
% Get estimated trajectory from pose graph
pGraphTraj = pGraph.nodes;

% Get estimated trajectory from feature-based registration without pose
% graph optimization
fpfhEstimatedTraj = zeros(count,3);
for i = 1:count
    fpfhEstimatedTraj(i,:) = fpfhTform(i).Translation;
end

% Create a figure window to visualize the ground truth and estimated
% trajectories
hFigTraj = figure;
```

```

axTraj = axes('Parent',hFigTraj,'Color','black');
plot3(fpfhEstimatedTraj(:,1),fpfhEstimatedTraj(:,2),fpfhEstimatedTraj(:,3), ...
      'r*', 'Parent',axTraj)
hold on
plot3(pGraphTraj(:,1),pGraphTraj(:,2),pGraphTraj(:,3),'b.','Parent',axTraj)
plot3(gTruthWayPts(:,1),gTruthWayPts(:,2),gTruthWayPts(:,3),'go','Parent',axTraj)
hold off
axis equal
view(axTraj,2)
xlabel(axTraj,'X (m)')
ylabel(axTraj,'Y (m)')
zlabel(axTraj,'Z (m)')
title(axTraj,'Trajectory Comparison')
legend(axTraj,'Estimated trajectory without pose graph optimization', ...
        'Estimated trajectory with pose graph optimization', ...
        'Ground Truth Trajectory','Location','bestoutside')

```

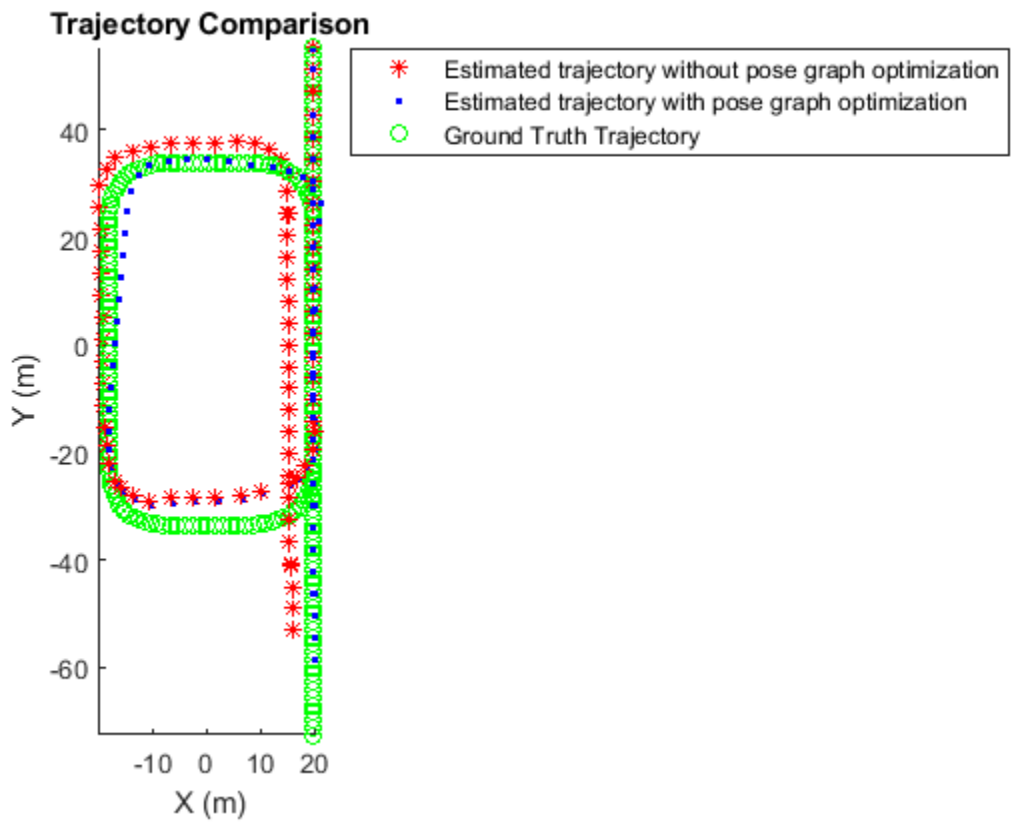

### Build and Visualize Generated Map

Transform and merge lidar scans using estimated poses to create an accumulated point cloud map.

```

% Get the estimated trajectory from poses
estimatedTraj = pGraphTraj(:,1:3);

% Convert relative poses to rigid transformations
estimatedTforms = rigid3d.empty(0);
for idx=1:pGraph.NumNodes
    pose = pGraph.nodes(idx);

```

```

    rigidPose = rigid3d((trvec2tform(pose(1:3)) * quat2tform(pose(4:7))));
    estimatedTforms(idx,1) = rigidPose;
end

% Create global map from processed point clouds and their relative poses
globalMap = pcalign(pcAccepted,estimatedTforms,alignGridStep);

% Create a figure window to visualize the estimated map and trajectory
hFigTrajMap = figure;
axTrajMap = axes('Parent',hFigTrajMap,'Color','black');
pcshow(estimatedTraj,'red','MarkerSize',150,'Parent',axTrajMap)
hold on
pcshow(globalMap,'MarkerSize',10,'Parent',axTrajMap)
hold off

% Customize axis labels
xlabel(axTrajMap,'X (m)')
ylabel(axTrajMap,'Y (m)')
zlabel(axTrajMap,'Z (m)')
title(axTrajMap,'Estimated Robot Trajectory And Generated Map')

```

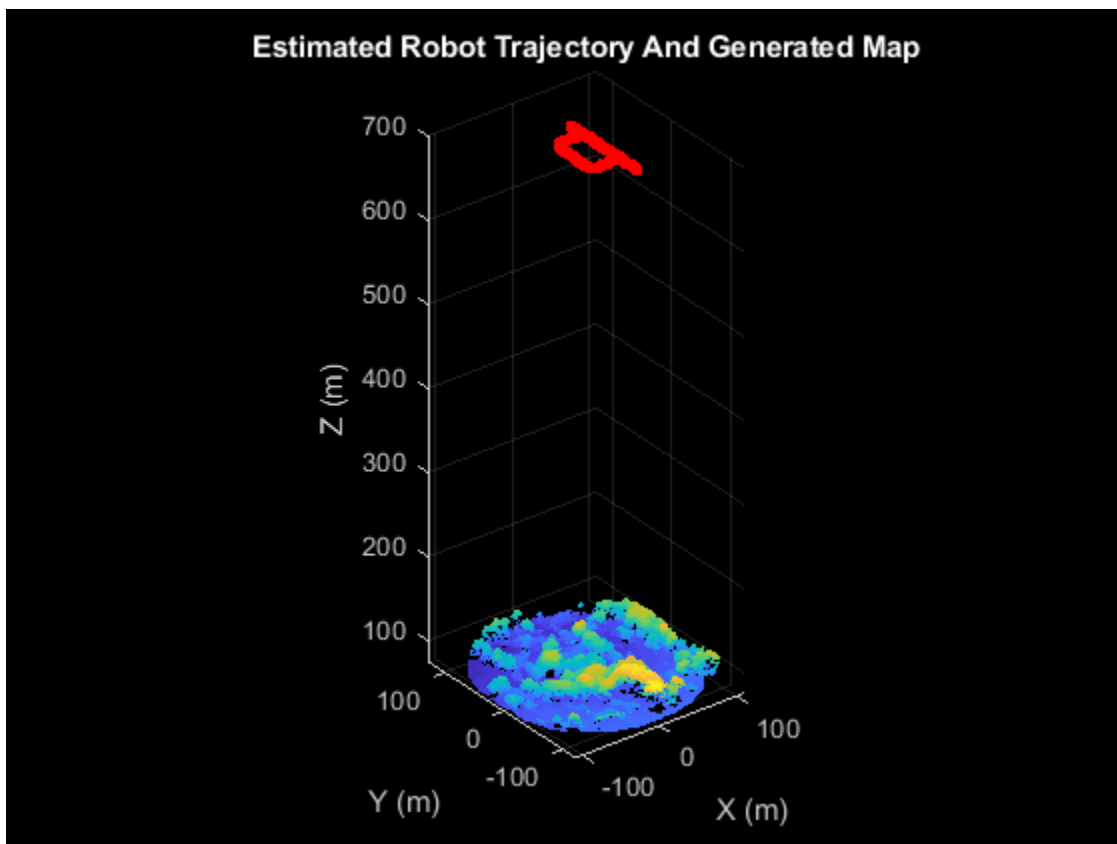

Visualize the ground truth map and the estimated map.

```

% Create a figure window to display both the ground truth map and estimated map
hFigMap = figure('Position',[0 0 700 400]);
axMap1 = subplot(1,2,1,'Color','black','Parent',hFigMap);
axMap1.Position = [0.08 0.2 0.4 0.55];
pcshow(orgMap,'Parent',axMap1)

```

```
xlabel(axMap1,'X (m)')
ylabel(axMap1,'Y (m)')
zlabel(axMap1,'Z (m)')
title(axMap1,'Ground Truth Map')

axMap2 = subplot(1,2,2,'Color','black','Parent',hFigMap);
axMap2.Position = [0.56 0.2 0.4 0.55];
pcshow(globalMap,'Parent',axMap2)
xlabel(axMap2,'X (m)')
ylabel(axMap2,'Y (m)')
zlabel(axMap2,'Z (m)')
title(axMap2,'Estimated Map')
```

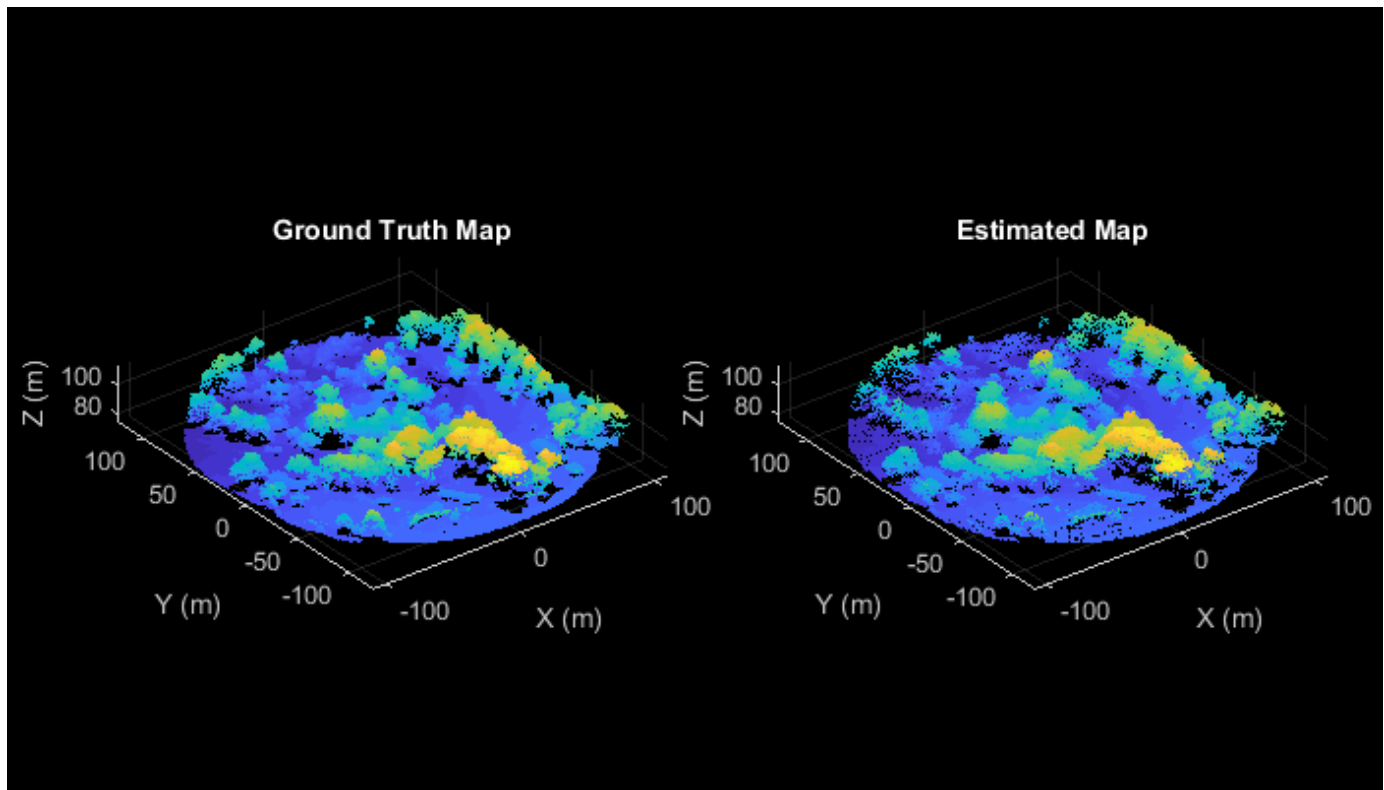

### See Also

#### Functions

[readPointCloud](#) | [insertPointCloud](#) (Navigation Toolbox) | [rayIntersection](#) (Navigation Toolbox) | [addRelativePose](#) (Navigation Toolbox) | [optimizePoseGraph](#) (Navigation Toolbox) | [show](#) (Navigation Toolbox) | [extractFPFHFeatures](#) | [pcmatchfeatures](#) | [estimateGeometricTransform3D](#) | [pcdownsample](#) | [pctransform](#) | [pcregistericp](#) | [pcalign](#) | [tform2trvec](#) (Navigation Toolbox) | [tform2quat](#) (Navigation Toolbox)

#### Objects

[lasFileReader](#) | [pointCloud](#) | [pcplayer](#) | [occupancyMap3D](#) (Navigation Toolbox) | [poseGraph3D](#) (Navigation Toolbox) | [rigid3d](#)

## References

[1] Starr, Scott. "Tuscaloosa, AL: Seasonal Inundation Dynamics and Invertebrate Communities." National Center for Airborne Laser Mapping, December 1, 2011. OpenTopography(<https://doi.org/10.5069/G9SF2T3K>).

## Collision Warning Using 2-D Lidar

This example shows how to detect obstacles and warn of possible collisions using 2-D lidar data.

### Overview

Logistics warehouses are increasingly mounting 2-D lidars on automatic guided vehicles (AGV) for navigation purposes, due to the affordability, long range, and high resolution of the sensor. The sensors assist in collision detection, which is an important task for the safe navigation of AGVs in complex environments. This example shows how to represent a robot workspace populated with obstacles, generate 2-D lidar data, detect obstacles, and provide a warning before an impending collision.

### Create a Warehouse Map

To represent the environment of the robot workspace, define a `binaryOccupancyMap` (Navigation Toolbox) object that contains the floor plan of the warehouse. Each cell in the occupancy grid has a logical value. An occupied location is represented as 1 and a free location is represented as 0. You can use the occupancy information to generate synthetic 2-D lidar data.

Add obstacles to the map near to the defined route of AGV.

```
% Create a binary warehouse map and place obstacles at defined locations
map = helperCreateBinaryOccupancyMap;

% Visualize map with obstacles and AGV
figure
show(map)
title('Warehouse Floor Plan With Obstacles and AGV')

% Add AGV to the map
pose = [5 40 0];
helperPlotRobot(gca,pose);
```



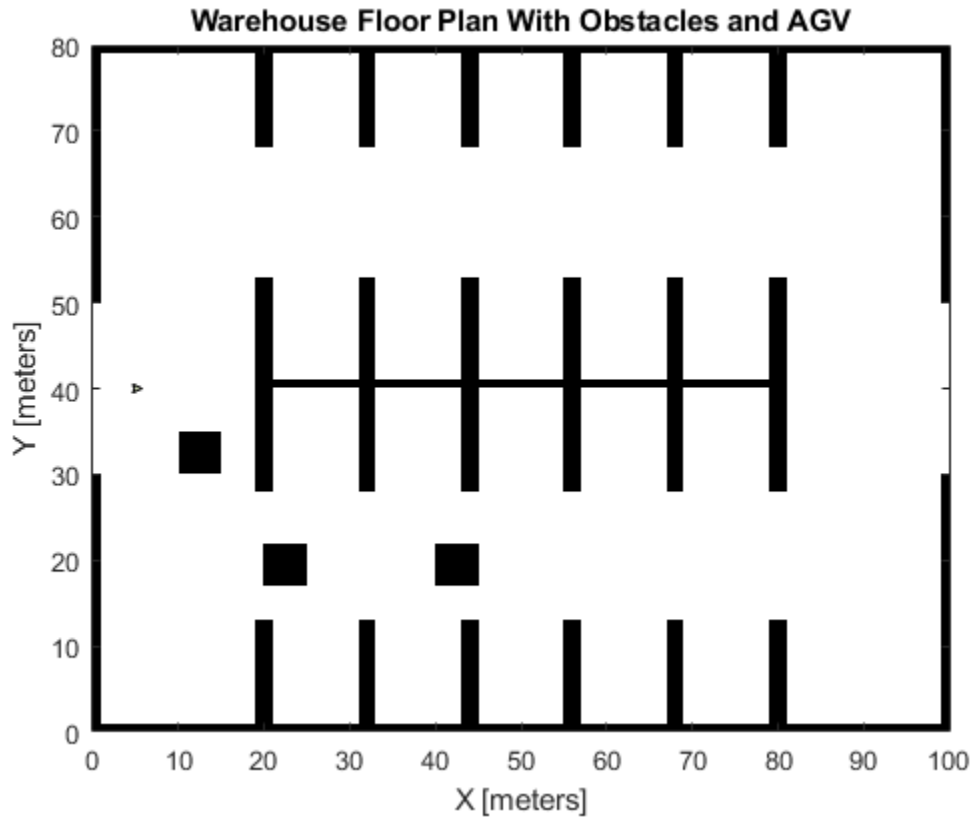

### Simulate 2-D Lidar Sensor

Simulate 2-D lidar sensor using a `rangeSensor` object to gather lidar readings for the generated map. Load a MAT-file containing the predefined waypoints of the AGV into the workspace. Use the simulated lidar sensor to return range and angle readings for a pose of the AGV, and then use the ranges and angles to generate a `lidarScan` object that contains the 2-D lidar scan.

```
% Simulate lidar sensor and set the detection angles to [-pi/2 pi/2]
lidar = rangeSensor;
lidar.HorizontalAngle = [-pi/2 pi/2];

% Set min and max values of the detectable range of the sensor in meters
lidar.Range = [0 5];

% Load waypoints through which AGV moves
load waypoints.mat
traj = waypointsMap;

% Select a waypoint to visualize scan data
Vehiclepose = traj(350,:);

% Generate lidar readings
[ranges,angles] = lidar(Vehiclepose,map);

% Store and visualize 2-D lidar scan
scan = lidarScan(ranges,angles);
plot(scan)
```

```
title('Ego View')
helperPlotRobot(gca,[0 0 Vehiclepose(3)]);
```

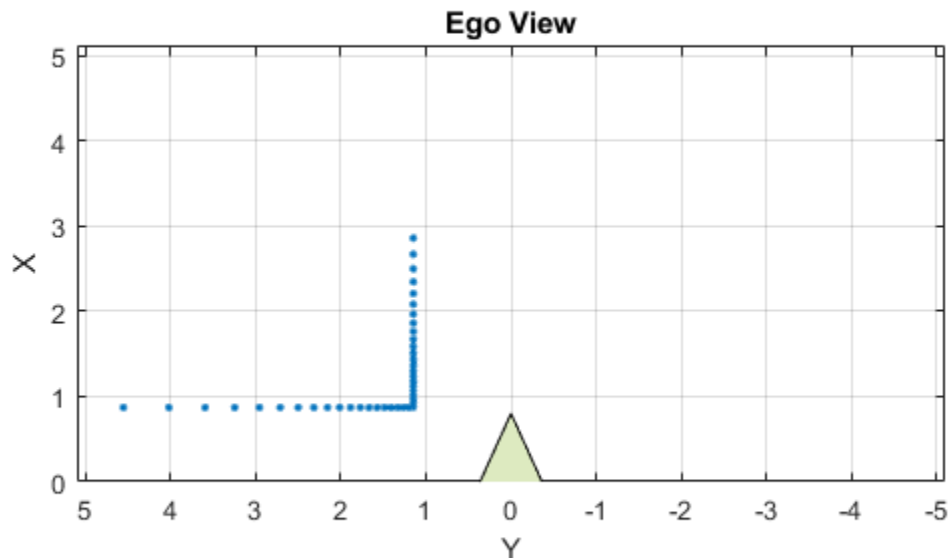

### Set Up Visualization

Set up a figure window that displays AGV movement in the warehouse, the associated lidar scans of the environment, displays obstacles as filled circles in bird's eye view, and color-coded collision warning messages. The color used for each warning signifies the likelihood of a collision based on the detection area zone that the obstacle occupies at that waypoint.

```
% Set up display
display = helperVisualizer;

% Plot warehouse map in the display window
hRobot = plotBinaryMap(display,map,pose);
```

### Collision Warning Based on Zones

Collision warnings only appear if an obstacle falls within the detection area of the AGV.

#### Define the Detection Area

Create a custom detectable area with different colors, shapes, and modify the area of color regions on figure GUI. Run the below portion of code and modify the polygon handles to accommodate your requirements of the detection area. The code below creates 3 polygon handles of semi-circular regions with a radius of 5, 2, 1 in meters and AGV is positioned at [0 0]. Modify the radius or change the polygon objects to create a custom detection area.

```

figure
detAxes = gca;
title(detAxes, 'Define Detection Area')
axis(detAxes, [-2 10 -2 4])
xlabel(detAxes, 'X')
ylabel(detAxes, 'Y')
axis(detAxes, 'equal')
grid(detAxes, 'minor')
t = linspace(-pi/2, pi/2, 30)';

% Specify color values - white, yellow, orange, red
colors = [1 1 1; 1 1 0; 1 0.5 0; 1 0 0];

% Specify radius in meters
radius = [5 2 1];

% Create a 3x1 matrix of type Polygon
detAreaHandles = repmat(images.roi.Polygon, [3 1]);

pos = [cos(t) sin(t)]*radius(1);
pos = [0 -2; pos(14:17, :); 0 2];
detAreaHandles(1) = drawpolygon( ...
    'Parent', detAxes, ...
    'InteractionsAllowed', 'reshape', ...
    'Position', pos, ...
    'StripeColor', 'black', ...
    'Color', colors(2, :));

pos = [cos(t) sin(t)]*radius(2);
pos = [0 -1.5; pos(12:19, :); 0 1.5];
detAreaHandles(2) = drawpolygon( ...
    'Parent', detAxes, ...
    'InteractionsAllowed', 'reshape', ...
    'Position', pos, ...
    'StripeColor', 'black', ...
    'Color', colors(3, :));

pos = [cos(t) sin(t)]*radius(3);
pos = [0 -1; pos(10:21, :); 0 1];
detAreaHandles(3) = drawpolygon( ...
    'Parent', detAxes, ...
    'InteractionsAllowed', 'reshape', ...
    'Position', pos, ...
    'StripeColor', 'black', ...
    'Color', colors(4, :));

% Pausing for the detection area window to load
pause(2)

```

To save the created detection area, run the `helperSaveDetectionArea` function. Use the axes handle of the figure with the detection area polygons and the associated `detAreaHandles` variable as input arguments. The function outputs the detection area, as a matrix of datatype `uint8`, and a bounding box. The blue rectangle around the detection area represents the bounding box.

```

% Axes of the figure window containing the polygon handles
axesDet = gca;
[detArea, bbox] = helperSaveDetectionArea(axesDet, detAreaHandles);

```

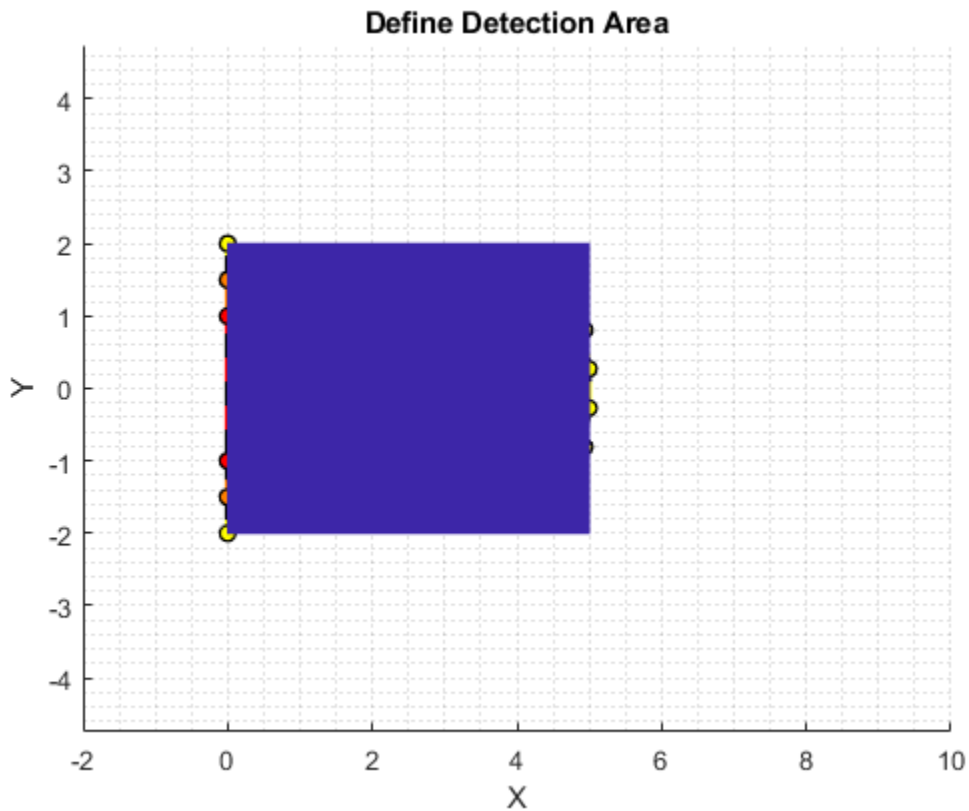

```
% Make detection area transparent by scaling colors
% alphadata = double(detArea ~= 0)*0.5;
ax3 = getDetectionAreaAxes(display);
h = imagesc(ax3, [bbox(1) (bbox(1)+bbox(3))], ...
    -[bbox(2) (bbox(2)+bbox(4))], ...
    detArea);

colormap(ax3,colors);

% Plot detection area
plotObstacleDisplay(display)
```

### Run Simulation

The detection area is divided into three levels as: red, orange, and yellow. Each region is associated with a specific degree of danger:

- Red — Collision is imminent
- Orange — High chance of collision
- Yellow — Apply caution measures

Obstacles that do not fall within the detection range are at safe distance from AGV. These are the primary steps involved in collision warning:

- Simulate 2-D lidar and extract point cloud data.
- Segment point cloud data into obstacle clusters.

- Loop over each obstacle to check for possible collisions.
- Issue a warning based on the danger level of obstacles.
- Display obstacles close to the AGV.

```
% Move AGV through waypoints
for ij = 27:size(traj,1)
    currentPose = traj(ij,:);
```

### Simulate 2-D Lidar and Extract Point Cloud Data

Gather lidar readings of the map using the simulated sensor. Load the current pose of the AGV from the waypoints file. Use the rangeSensor object you created to get range and angle measurement.

```
% Retrieve lidar scans
[ranges,angles] = lidar(currentPose,map);
scan = lidarScan(ranges,angles);

% Store 2-D scan as point cloud
cart = scan.Cartesian;
cart(:,3) = 0;
pc = pointCloud(cart);
```

### Segment Point Cloud Data into Obstacle Clusters

Use the pcsegdist function to segment the scanned point cloud into clusters, using minimum euclidean distance between the points as the segmentation criterion.

```
% Segment point cloud into clusters based on euclidean distance
minDistance = 0.9;
[labels,numClusters] = pcsegdist(pc,minDistance);
```

### Update Visualization Window with Map and Scan Data

```
% Update display map
updateMapDisplay(display,hRobot,currentPose);

% Plot 2-D lidar scans
plotLidarScan(display,scan,currentPose(3));

% Delete obstacles from last scan to plot next scan line
if exist('sc','var')
    delete(sc)
    clear sc
end
```

### Loop Over Each Obstacle to Find the Likelihood of Collisions

Loop through the clusters based on their labels, to extract the points located inside them.

```
nearxy = zeros(numClusters,2);
maxlevel = -inf;
% Loop through all the clusters in pc
for i = 1:numClusters
    c = find(labels == i);
    % XY coordinate extraction of obstacle
    xy = pc.Location(c,1:2);
```

Convert the world position of each obstacle into the camera coordinate system.

```
% Convert to normalized coordinate system (0-> minimum location of detection
% area, 1->maximum position of detection area)
a = [xy(:,1) xy(:,2)] - repmat(bbox([1 2]),[size(xy,1) 1]);
b = repmat(bbox([3 4]),[size(xy,1) 1]);
xy_org = a./b;

% Coordinate system (0, 0)->(0, 0), (1, 1)->(width, height) of detArea
idx = floor(xy_org.*repmat([size(detArea,2) size(detArea,1)],[size(xy_org,1) 1]));
```

Extract the indices of obstacle points that lie in the detection area.

```
% Extracts as an index only the coordinates in detArea
validIdx = 1 <= idx(:,1) & 1 <= idx(:,2) & ...
    idx(:,1) <= size(detArea,2) & idx(:,2) <= size(detArea,1);
```

For each valid obstacle point, find the associated value in the detection matrix. The maximum value of all associated points in the detection matrix determines the level of danger represented by that obstacle. Display a colored circle based on the danger level of the obstacle in the **Warning Color** pane of the visualization window.

```
% Round the index and get the level of each obstacle from detArea
cols = idx(validIdx,1);
rows = idx(validIdx,2);
levels = double(detArea(sub2ind(size(detArea),rows,cols)));

if ~isempty(levels)
    level = max(levels);
    maxlevel = max(maxlevel,level);
    xyInds = find(validIdx);
    xyInds = xyInds(levels == level);

    % Get the nearest coordinates of obstacle in detection area
    nearxy(i,:) = helperNearObstacles(xy(xyInds,:));
else
    % Get the nearest coordinates of obstacle in the cluster
    nearxy(i,:) = helperNearObstacles(xy);
end
end
% Display a warning color representing the danger level. If the
% obstacle does not fall in the detection area, do not display a color.
switch maxlevel
    % Red region
    case 3
        circleDisplay(display,colors(4,:))
    % Orange region
    case 2
        circleDisplay(display,colors(3,:))
    % Yellow region
    case 1
        circleDisplay(display,colors(2,:))
    % Default case
    otherwise
        circleDisplay(display,[])
end
```

### Display Points of Obstacles Closest to the AGV

As most of the obstacles in the warehouse are linear and long, display only the point of each obstacle cluster closest to the AGV. Obstacles display as filled circles in the **Bird's-Eye Plot** pane of the visualization window.

```

for i = 1:numClusters
    % Display obstacles if exist in the mentioned range of axes3
    sc(i,:) = displayObstacles(display,nearxy(i,:));
end
updateDisplay(display)
pause(0.01)
end

```

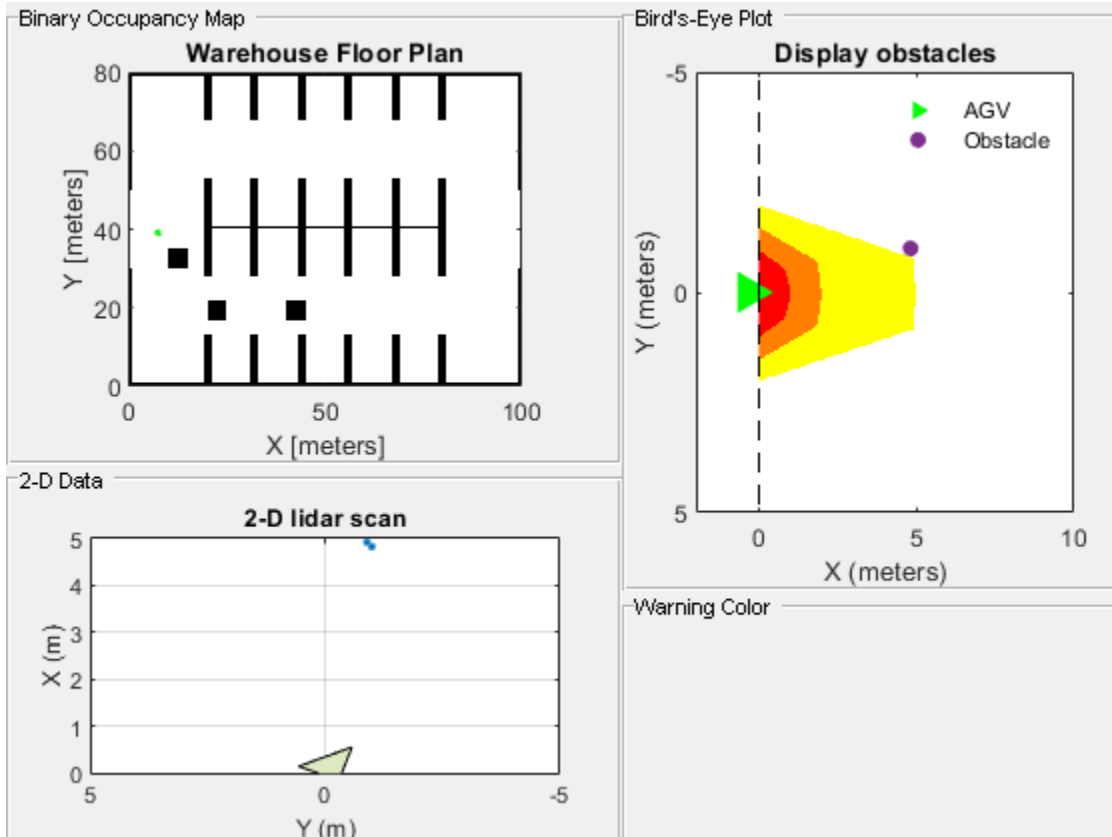

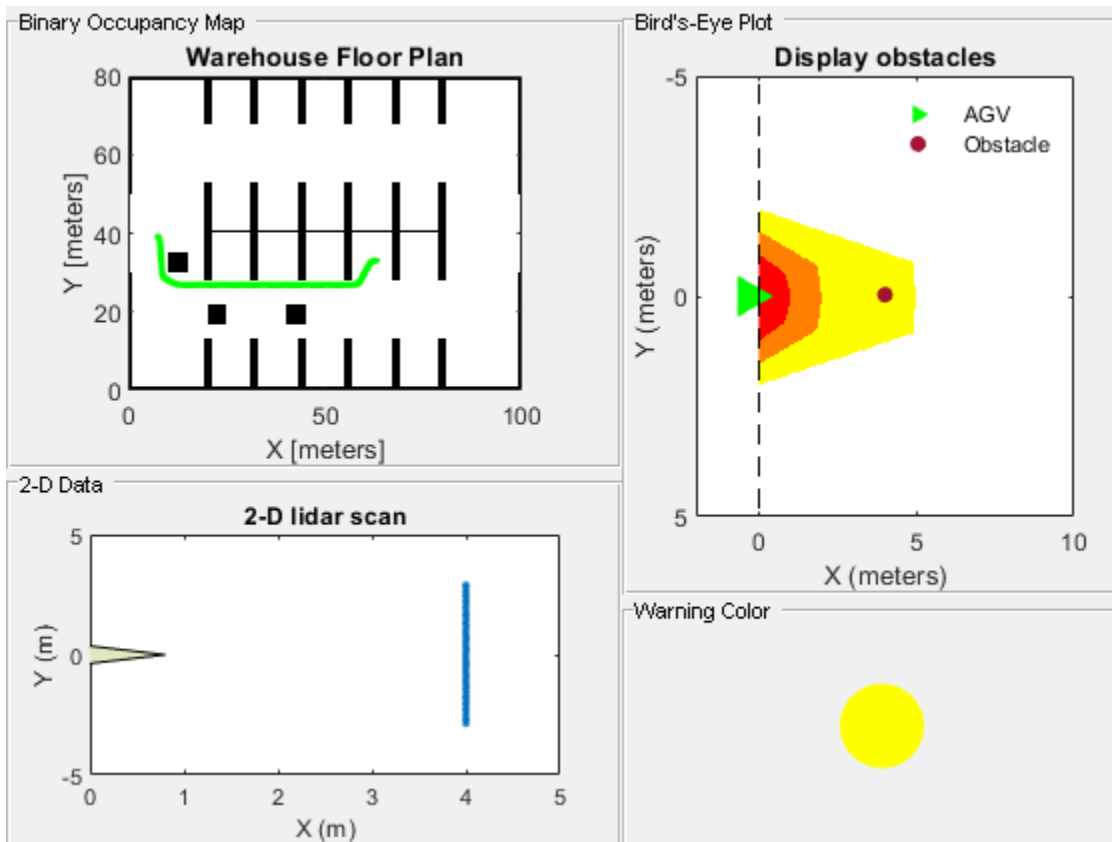

### Supporting Files

**helperCreateBinaryOccupancyMap** creates a warehouse map of the robot workspace

```
function map = helperCreateBinaryOccupancyMap()
```

```
% helperCreateBinaryOccupancyMap Creates a warehouse map with specific  
% resolution passed as arguments to binaryOccupancyMap
```

```
map = binaryOccupancyMap(100,80,1);  
occ = zeros(80,100);  
occ(1,:) = 1;  
occ(end,:) = 1;  
occ([1:30,51:80],1) = 1;  
occ([1:30,51:80],end) = 1;  
occ(40,20:80) = 1;  
occ(28:52,[20:21 32:33 44:45 56:57 68:69 80:81]) = 1;  
occ(1:12,[20:21 32:33 44:45 56:57 68:69 80:81]) = 1;  
occ(end-12:end,[20:21 32:33 44:45 56:57 68:69 80:81]) = 1;
```

```
% Set occupancy value of locations  
setOccupancy(map,occ);
```

```
% Add obstacles to the map at specific locations. Inputs to  
% helperAddObstacle are obstacleWidth, obstacleHeight and obstacleLocation.  
helperAddObstacle(map,5,5,[10,30]);  
helperAddObstacle(map,5,5,[20,17]);  
helperAddObstacle(map,5,5,[40,17]);  
end
```



```
%helperAddObstacle Adds obstacles to the occupancy map  
function helperAddObstacle(map,obstacleWidth,obstacleHeight,obstacleLocation)  
values = ones(obstacleHeight,obstacleWidth);  
setOccupancy(map,obstacleLocation,values)  
end
```

**See also**

binaryOccupancyMap (Navigation Toolbox) | lidarScan | rangeSensor | pcsegdist

## Track Vehicles Using Lidar: From Point Cloud to Track List

This example shows you how to track vehicles using measurements from a lidar sensor mounted on top of an ego vehicle. Lidar sensors report measurements as a point cloud. The example illustrates the workflow in MATLAB® for processing the point cloud and tracking the objects. For a Simulink® version of the example, refer to “Track Vehicles Using Lidar Data in Simulink” (Sensor Fusion and Tracking Toolbox). The lidar data used in this example is recorded from a highway driving scenario. In this example, you use the recorded data to track vehicles with a joint probabilistic data association (JPDA) tracker and an interacting multiple model (IMM) approach.

### 3-D Bounding Box Detector Model

Due to high resolution capabilities of the lidar sensor, each scan from the sensor contains a large number of points, commonly known as a point cloud. This raw data must be preprocessed to extract objects of interest, such as cars, cyclists, and pedestrians. In this example, you use a classical segmentation algorithm using a distance-based clustering algorithm. For more details about segmentation of lidar data into objects such as the ground plane and obstacles, refer to the “Ground Plane and Obstacle Detection Using Lidar” (Automated Driving Toolbox) example. For a deep learning segmentation workflow, refer to the “Detect, Classify, and Track Vehicles Using Lidar” on page 1-139 example. In this example, the point clouds belonging to obstacles are further classified into clusters using the `pcsegdist` function, and each cluster is converted to a bounding box detection with the following format:

$$[x \ y \ z \ \theta \ l \ w \ h]$$

$x$ ,  $y$  and  $z$  refer to the x-, y- and z-positions of the bounding box,  $\theta$  refers to its yaw angle and  $l$ ,  $w$  and  $h$  refer to its length, width, and height, respectively. The `pcfitcuboid` function uses L-shape fitting algorithm to determine the yaw angle of the bounding box.

The detector is implemented by a supporting class `HelperBoundingBoxDetector`, which wraps around point cloud segmentation and clustering functionalities. An object of this class accepts a `pointCloud` input and returns a list of `objectDetection` objects with bounding box measurements.

The diagram shows the processes involved in the bounding box detector model and the Lidar Toolbox™ functions used to implement each process. It also shows the properties of the supporting class that control each process.

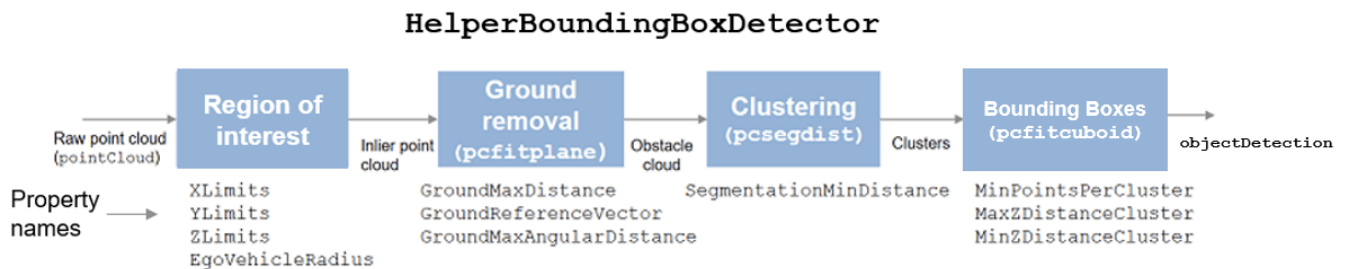

The lidar data is available at the following location: <https://ssd.mathworks.com/supportfiles/lidar/data/TrackVehiclesUsingLidarExampleData.zip>

Download the data files into your temporary directory, whose location is specified by MATLAB's `tempdir` function. If you want to place the files in a different folder, change the directory name in the subsequent instructions.

```
% Load data if unavailable. The lidar data is stored as a cell array of
% pointCloud objects.
if ~exist('lidarData','var')
    dataURL = 'https://ssd.mathworks.com/supportfiles/lidar/data/TrackVehiclesUsingLidarExampleD';
    datasetFolder = fullfile(tempdir,'LidarExampleDataset');
    if ~exist(datasetFolder,'dir')
        unzip(dataURL,datasetFolder);
    end
    % Specify initial and final time for simulation.
    initTime = 0;
    finalTime = 35;
    [lidarData, imageData] = loadLidarAndImageData(datasetFolder,initTime,finalTime);
end

% Set random seed to generate reproducible results.
S = rng(2018);

% A bounding box detector model.
detectorModel = HelperBoundingBoxDetector(...
    'XLimits',[-50 75],...           % min-max
    'YLimits',[-5 5],...           % min-max
    'ZLimits',[-2 5],...           % min-max
    'SegmentationMinDistance',1.8,... % minimum Euclidian distance
    'MinDetectionsPerCluster',1,... % minimum points per cluster
    'MeasurementNoise',blkdiag(0.25*eye(3),25,eye(3)),... % measurement noise in detection
    'GroundMaxDistance',0.3);      % maximum distance of ground points from ground plane
```

### Target State and Sensor Measurement Model

The first step in tracking an object is defining its state, and the models that define the transition of state and the corresponding measurement. These two sets of equations are collectively known as the state-space model of the target. To model the state of vehicles for tracking using lidar, this example uses a cuboid model with following convention:

$$x = [x_{kin} \ \theta \ l \ w \ h]$$

$x_{kin}$  refers to the portion of the state that controls the kinematics of the motion center, and  $\theta$  is the yaw angle. The length, width, and height of the cuboid are modeled as constants, whose estimates evolve in time during correction stages of the filter.

In this example, you use two state-space models: a constant velocity (cv) cuboid model and a constant turn-rate (ct) cuboid model. These models differ in the way they define the kinematic part of the state, as described below:

$$x_{cv} = [x \ \dot{x} \ y \ \dot{y} \ z \ \dot{z} \ \theta \ l \ w \ h]$$

$$x_{ct} = [x \ \dot{x} \ y \ \dot{y} \ \dot{\theta} \ z \ \dot{z} \ \theta \ l \ w \ h]$$

For information about their state transition, refer to the `helperConstvelCuboid` and `helperConstturnCuboid` functions used in this example.

The `helperCvmeasCuboid` and `helperCtmeasCuboid` measurement models describe how the sensor perceives the constant velocity and constant turn-rate states respectively, and they return

bounding box measurements. Because the state contains information about size of the target, the measurement model includes the effect of center-point offset and bounding box shrinkage, as perceived by the sensor, due to effects like self-occlusion [1]. This effect is modeled by a shrinkage factor that is directly proportional to the distance from the tracked vehicle to the sensor.

The image below demonstrates the measurement model operating at different state-space samples. Notice the modeled effects of bounding box shrinkage and center-point offset as the objects move around the ego vehicle.

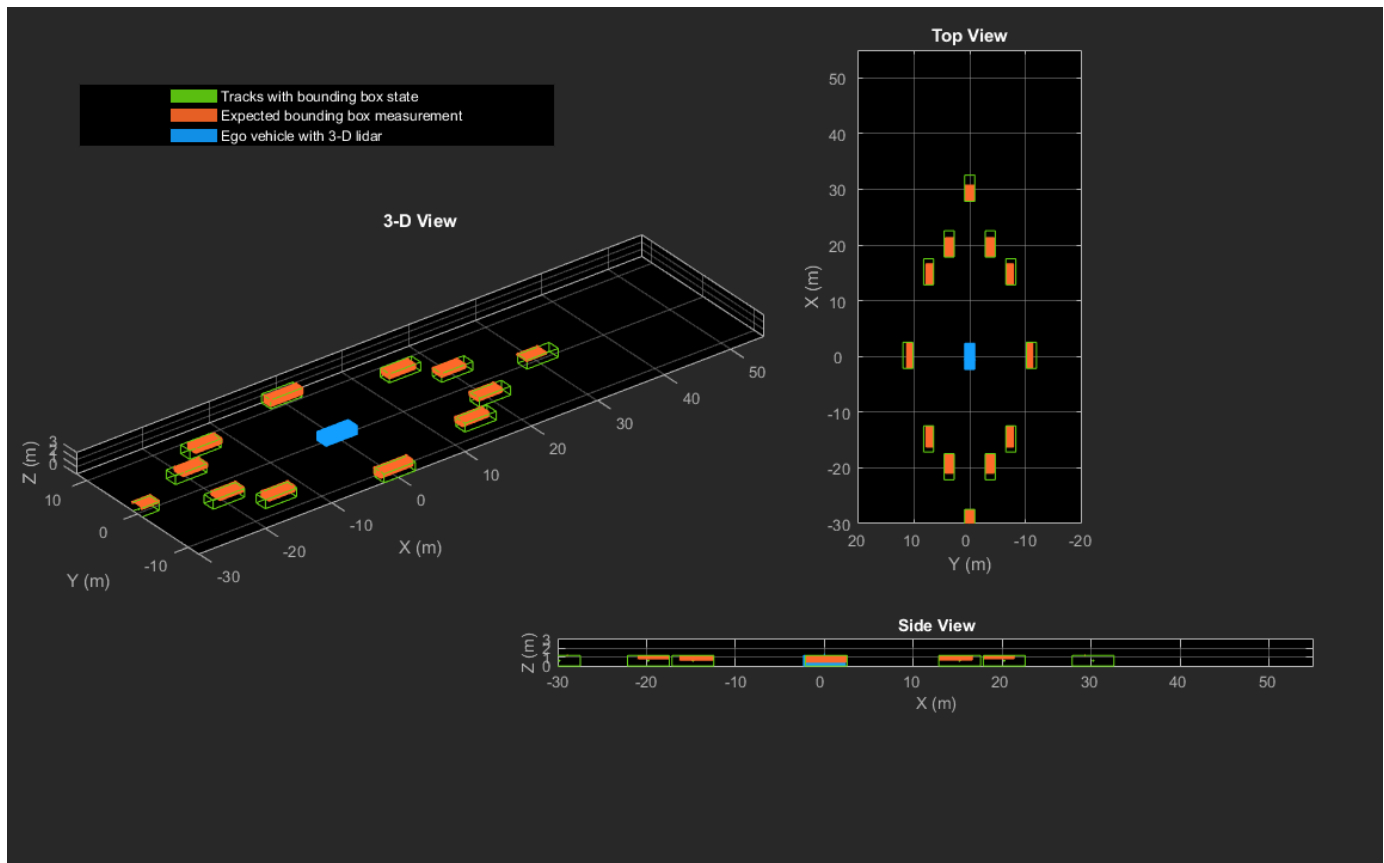

### Set Up Tracker and Visualization

The image below shows the complete workflow to obtain a list of tracks from a pointCloud input.

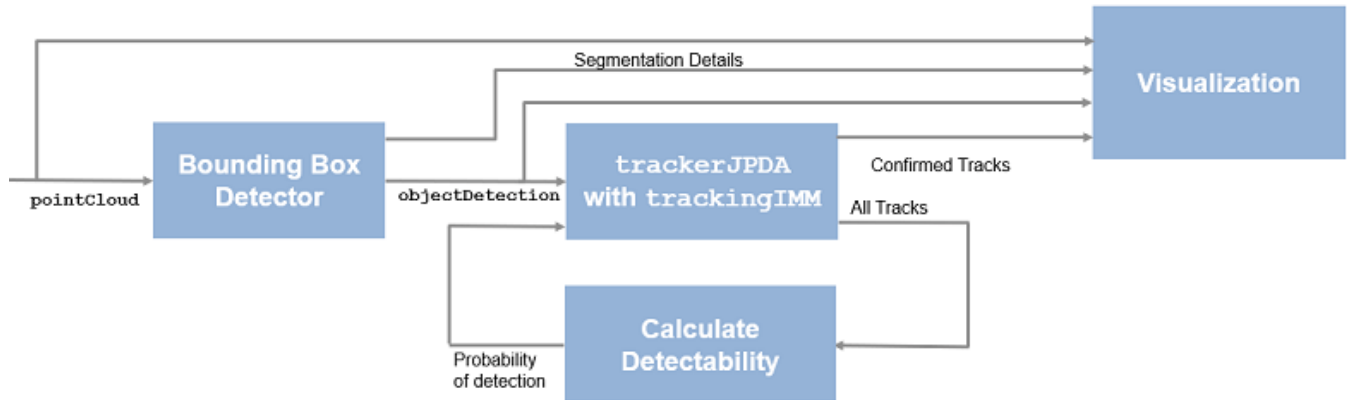

Now, set up the tracker and the visualization used in the example.

A joint probabilistic data association tracker (`trackerJPDA`) coupled with an IMM filter (`trackingIMM`) is used to track objects in this example. The IMM filter uses a constant velocity and constant turn-rate model and is initialized using the supporting function, `helperInitIMMFilter`, included with this example. The IMM approach helps a track to switch between motion models and thus achieve good estimation accuracy during events like maneuvering or lane changing. The animation below shows the effect of mixing the constant velocity and constant turn-rate model during prediction stages of the IMM filter.

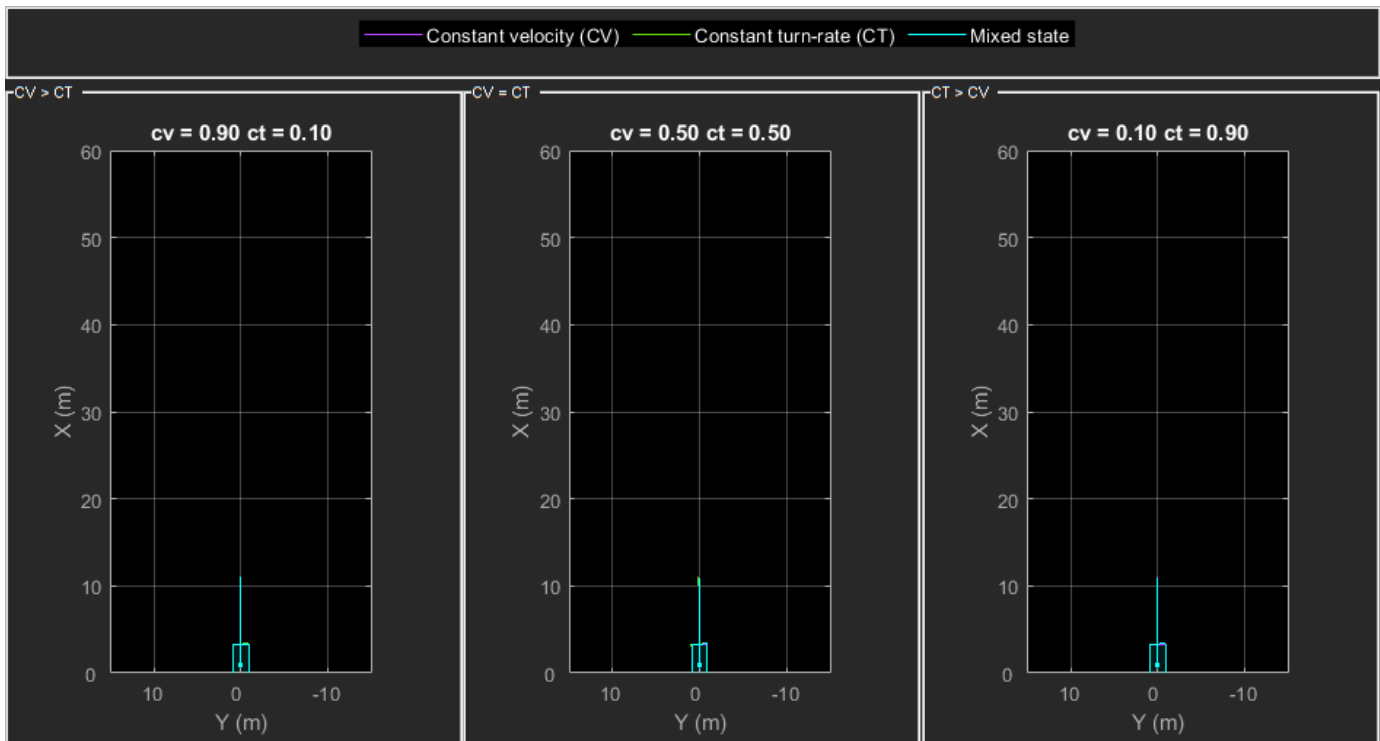

The IMM filter updates the probability of each model when it is corrected with detections from the object. The animation below shows the estimated trajectory of a vehicle during a lane change event and the corresponding estimated probabilities of each model.

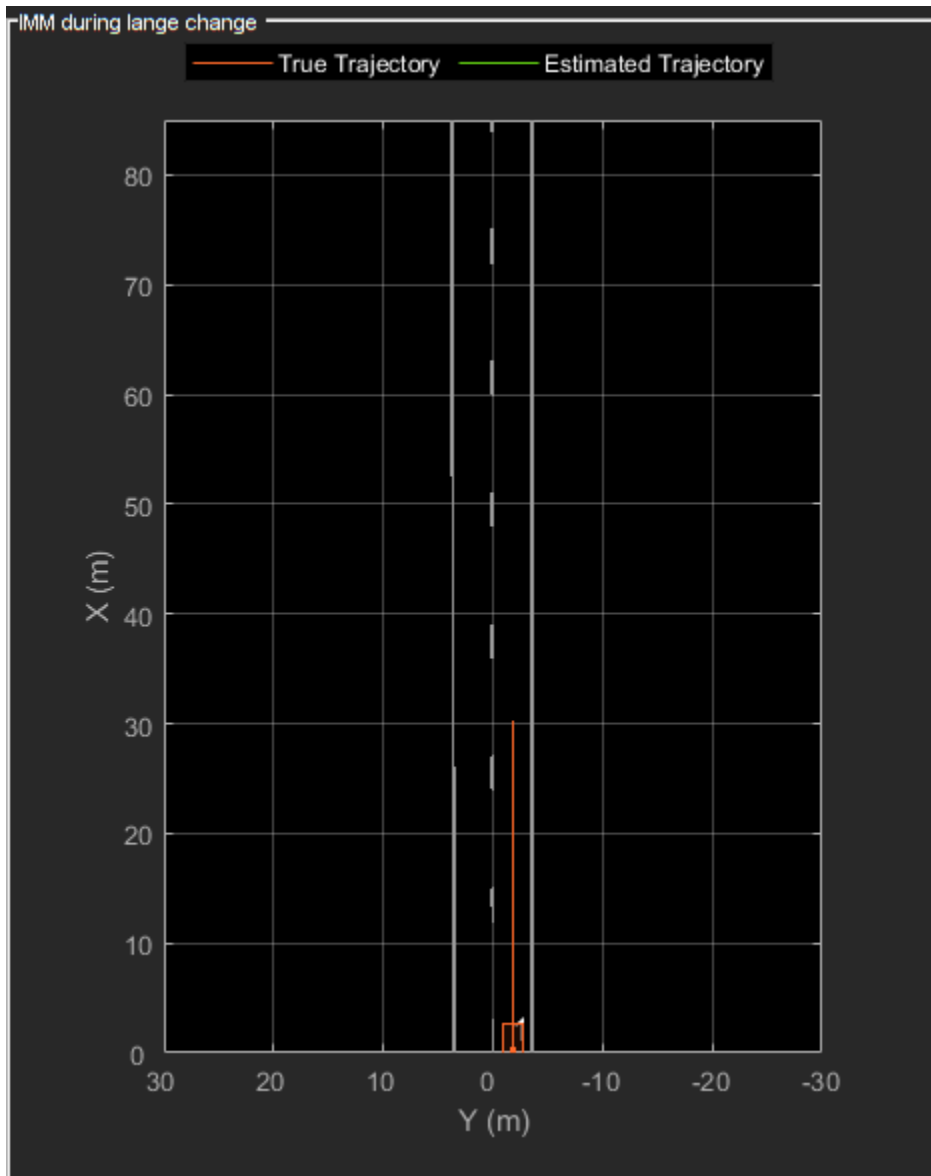

Set the `HasDetectableTrackIDsInput` property of the tracker as `true`, which enables you to specify a state-dependent probability of detection. The detection probability of a track is calculated by the `helperCalcDetectability` function, listed at the end of this example.

```
assignmentGate = [75 1000]; % Assignment threshold;
confThreshold = [7 10];    % Confirmation threshold for history logic
delThreshold = [8 10];    % Deletion threshold for history logic
Kc = 1e-9;                 % False-alarm rate per unit volume

% IMM filter initialization function
filterInitFcn = @helperInitIMMFilter;

% A joint probabilistic data association tracker with IMM filter
tracker = trackerJPDA('FilterInitializationFcn',filterInitFcn,...
    'TrackLogic','History',...
    'AssignmentThreshold',assignmentGate,...
```

```

'ClutterDensity',Kc,...
'ConfirmationThreshold',confThreshold,...
'DeletionThreshold',delThreshold,...
'HasDetectableTrackIDsInput',true,...
'InitializationThreshold',0,...
'HitMissThreshold',0.1);

```

The visualization is divided into these main categories:

- 1 Lidar Preprocessing and Tracking - This display shows the raw point cloud, segmented ground, and obstacles. It also shows the resulting detections from the detector model and the tracks of vehicles generated by the tracker.
- 2 Ego Vehicle Display - This display shows the 2-D bird's-eye view of the scenario. It shows the obstacle point cloud, bounding box detections, and the tracks generated by the tracker. For reference, it also displays the image recorded from a camera mounted on the ego vehicle and its field of view.
- 3 Tracking Details - This display shows the scenario zoomed around the ego vehicle. It also shows finer tracking details, such as error covariance in estimated position of each track and its motion model probabilities, denoted by cv and ct.

```

% Create display
displayObject = HelperLidarExampleDisplay(imageData{1},...
'PositionIndex',[1 3 6],...
'VelocityIndex',[2 4 7],...
'DimensionIndex',[9 10 11],...
'YawIndex',8,...
'MovieName','',... % Specify a movie name to record a movie.
'RecordGIF',false); % Specify true to record new GIFs

```

### Loop Through Data

Loop through the recorded lidar data, generate detections from the current point cloud using the detector model and then process the detections using the tracker.

```

time = 0;          % Start time
dT = 0.1;         % Time step

% Initiate all tracks.
allTracks = struct([]);

% Initiate variables for comparing MATLAB and MEX simulation.
numTracks = zeros(numel(lidarData),2);

% Loop through the data
for i = 1:numel(lidarData)
    % Update time
    time = time + dT;

    % Get current lidar scan
    currentLidar = lidarData{i};

    % Generator detections from lidar scan.
    [detections,obstacleIndices,groundIndices,croppedIndices] = detectorModel(currentLidar,time)

    % Calculate detectability of each track.
    detectableTracksInput = helperCalcDetectability(allTracks,[1 3 6]);

```

```
% Pass detections to track.
[confirmedTracks,tentativeTracks,allTracks,info] = tracker(detections,time,detectableTracksI
numTracks(i,1) = numel(confirmedTracks);

% Get model probabilities from IMM filter of each track using
% getTrackFilterProperties function of the tracker.
modelProbs = zeros(2,numel(confirmedTracks));
for k = 1:numel(confirmedTracks)
    c1 = getTrackFilterProperties(tracker,confirmedTracks(k).TrackID,'ModelProbabilities');
    modelProbs(:,k) = c1{1};
end

% Update display
if isValid(displayObject.PointCloudProcessingDisplay.ObstaclePlotter)
    % Get current image scan for reference image
    currentImage = imageData{i};

    % Update display object
    displayObject(detections,confirmedTracks,currentLidar,obstacleIndices,...
        groundIndices,croppedIndices,currentImage,modelProbs);
end

% Snap a figure at time = 18
if abs(time - 18) < dT/2
    snapnow(displayObject);
end

end

% Write movie if requested
if ~isempty(displayObject.MovieName)
    writeMovie(displayObject);
end

% Write new GIFs if requested.
if displayObject.RecordGIF
    % second input is start frame, third input is end frame and last input
    % is a character vector specifying the panel to record.
    writeAnimatedGIF(displayObject,10,170,'trackMaintenance','ego');
    writeAnimatedGIF(displayObject,310,330,'jpda','processing');
    writeAnimatedGIF(displayObject,120,140,'imm','details');
end
```



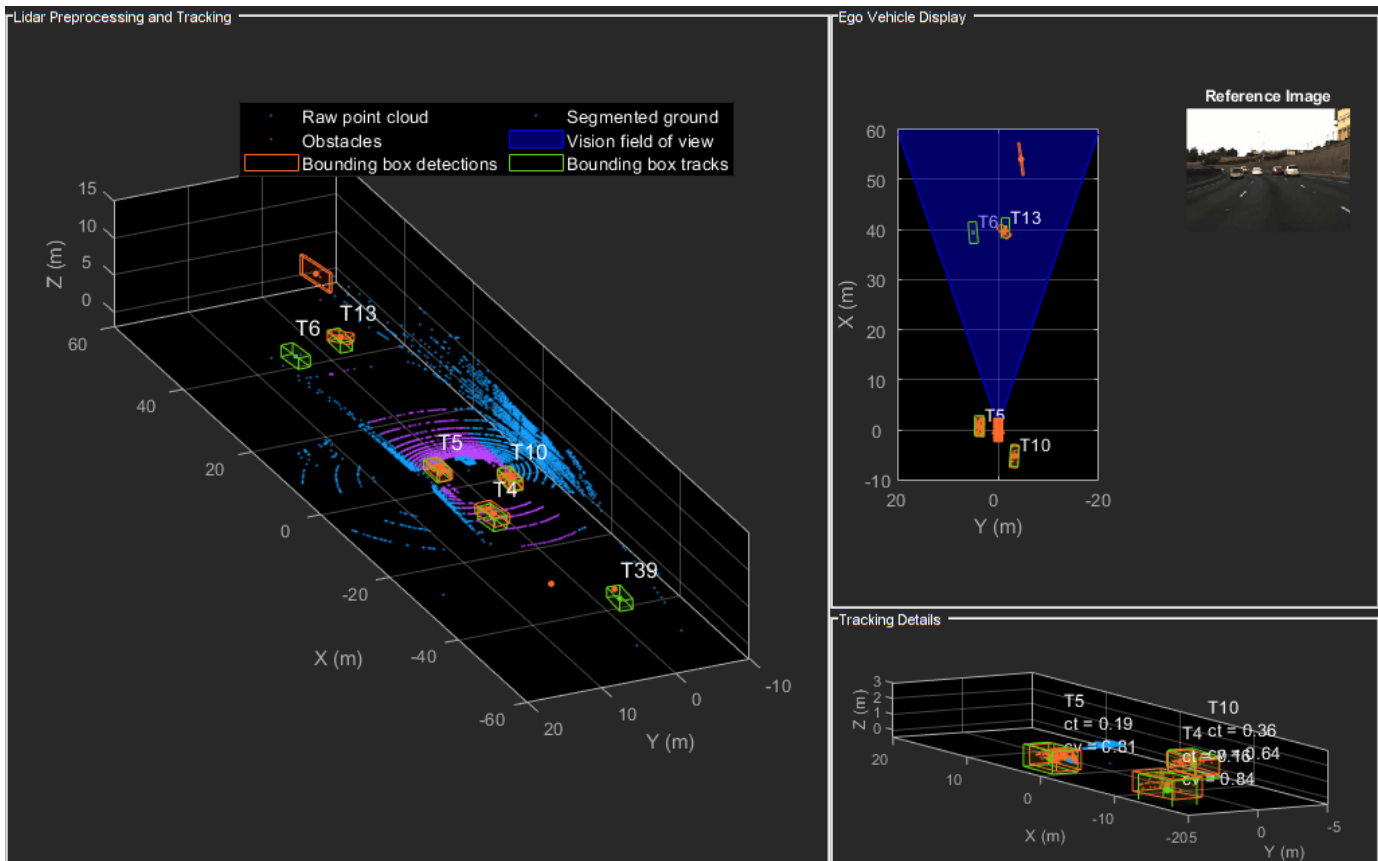

The figure above shows the three displays at time = 18 seconds. The tracks are represented by green bounding boxes. The bounding box detections are represented by orange bounding boxes. The detections also have orange points inside them, representing the point cloud segmented as obstacles. The segmented ground is shown in purple. The cropped or discarded point cloud is shown in blue.

### Generate C Code

You can generate C code from the MATLAB® code for the tracking and the preprocessing algorithm using MATLAB Coder™. C code generation enables you to accelerate MATLAB code for simulation. To generate C code, the algorithm must be restructured as a MATLAB function, which can be compiled into a MEX file or a shared library. For this purpose, the point cloud processing algorithm and the tracking algorithm is restructured into a MATLAB function, `mexLidarTracker`. Some variables are defined as `persistent` to preserve their state between multiple calls to the function (see `persistent`). The inputs and outputs of the function can be observed in the function description provided in the "Supporting Files" section at the end of this example.

MATLAB Coder requires specifying the properties of all the input arguments. An easy way to do this is by defining the input properties by example at the command line using the `-args` option. For more information, see "Define Input Properties by Example at the Command Line" (MATLAB Coder). Note that the top-level input arguments cannot be objects of the `handle` class. Therefore, the function accepts the `x`, `y` and `z` locations of the point cloud as an input. From the stored point cloud, this information can be extracted using the `Location` property of the `pointCloud` object. This information is also directly available as the raw data from the lidar sensor.

```
% Input lists
inputExample = {lidarData{1}.Location, 0};

% Create configuration for MEX generation
cfg = coder.config('mex');

% Replace cfg with the following to generate static library and perform
% software-in-the-loop simulation. This requires an Embedded Coder license.
%
% cfg = coder.config('lib'); % Static library
% cfg.VerificationMode = 'SIL'; % Software-in-the-loop

% Generate code if file does not exist.
if ~exist('mexLidarTracker_mex','file')
    h = msgbox({'Generating code. This may take a few minutes...'; 'This message box will close w
    % -config allows specifying the codegen configuration
    % -o allows specifying the name of the output file
    codegen -config cfg -o mexLidarTracker_mex mexLidarTracker -args inputExample
    close(h);
else
    clear mexLidarTracker_mex;
end
```

### Rerun simulation with MEX Code

Rerun the simulation using the generated MEX code, mexLidarTracker\_mex. Reset time

```
time = 0;

for i = 1:numel(lidarData)
    time = time + dT;

    currentLidar = lidarData{i};

    [detectionsMex, obstacleIndicesMex, groundIndicesMex, croppedIndicesMex, ...
     confirmedTracksMex, modelProbsMex] = mexLidarTracker_mex(currentLidar.Location, time);

    % Record data for comparison with MATLAB execution.
    numTracks(i,2) = numel(confirmedTracksMex);
end
```

Compare results between MATLAB and MEX Execution

```
disp(isequal(numTracks(:,1), numTracks(:,2)));
```

1

Notice that the number of confirmed tracks is the same for MATLAB and MEX code execution. This assures that the lidar preprocessing and tracking algorithm returns the same results with generated C code as with the MATLAB code.

### Results

Now, analyze different events in the scenario and understand how the combination of lidar measurement model, joint probabilistic data association, and interacting multiple model filter, helps achieve a good estimation of the vehicle tracks.

### Track Maintenance

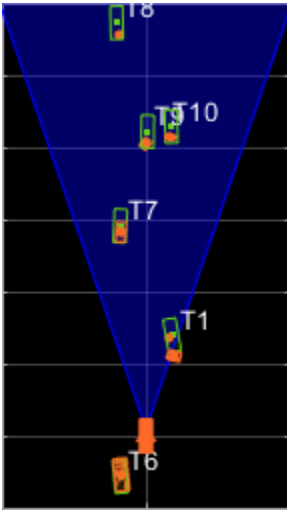

The animation above shows the simulation between time = 3 seconds and time = 16 seconds. Notice that tracks such as T10 and T6 maintain their IDs and trajectory during the time span. However, track T9 is lost because the tracked vehicle was missed (not detected) for a long time by the sensor. Also, notice that the tracked objects are able to maintain their shape and kinematic center by positioning the detections onto the visible portions of the vehicles. For example, as Track T7 moves forward, bounding box detections start to fall on its visible rear portion and the track maintains the actual size of the vehicle. This illustrates the offset and shrinkage effect modeled in the measurement functions.

### Capturing Maneuvers

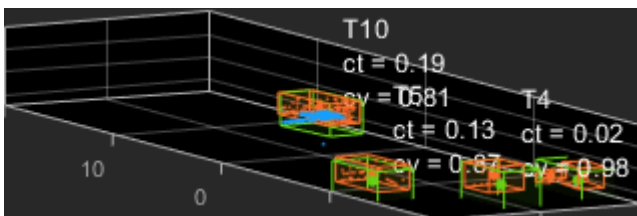

The animation shows that using an IMM filter helps the tracker to maintain tracks on maneuvering vehicles. Notice that the vehicle tracked by T4 changes lanes behind the ego vehicle. The tracker is able to maintain a track on the vehicle during this maneuvering event. Also notice in the display that its probability of following the constant turn model, denoted by  $ct$ , increases during the lane change maneuver.

### Joint Probabilistic Data Association

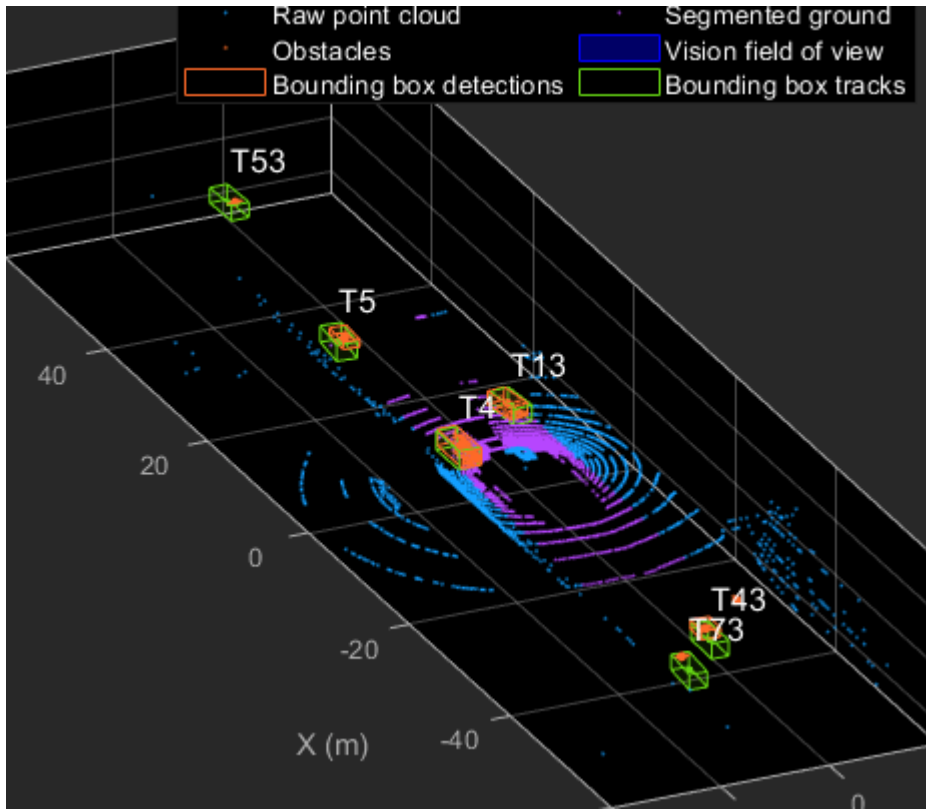

This animation shows that using a joint probabilistic data association tracker helps in maintaining tracks during ambiguous situations. Here, vehicles tracked by T43 and T73, have a low probability of detection due to their large distance from the sensor. Notice that the tracker is able to maintain tracks during events when one of the vehicles is not detected. During the event, the tracks first coalesce, which is a known phenomenon in JPDA, and then separate as soon as the vehicle was detected again.

### Summary

This example showed how to use a JPDA tracker with an IMM filter to track objects using a lidar sensor. You learned how a raw point cloud can be preprocessed to generate detections for conventional trackers, which assume one detection per object per sensor scan. You also learned how to define a cuboid model to describe the kinematics, dimensions, and measurements of extended objects being tracked by the JPDA tracker. In addition, you generated C code from the algorithm and verified its execution results with the MATLAB simulation.

### Supporting Files

This section highlights the code from some important supporting files used in this example. The complete list of supporting files can be found in the current working directory after opening the example in MATLAB.

```
% *helperLidarModel*
%
% This function defines the lidar model to simulate shrinkage of the
% bounding box measurement and center-point offset. This function is used
% in the |helperCvmeasCuboid| and |helperCtmeasCuboid| functions to obtain
% bounding box measurement from the state.
```

```
%
% <include>helperLidarModel.m</include>
%
```

### helperInverseLidarModel

This function defines the inverse lidar model to initiate a tracking filter using a lidar bounding box measurement. This function is used in the helperInitIMMFilter function to obtain state estimates from a bounding box measurement.

```
function [pos,posCov,dim,dimCov,yaw,yawCov] = helperInverseLidarModel(meas,measCov)
% This function returns the position, dimension, yaw using a bounding
% box measurement.
```

```
% Copyright 2019 The MathWorks, Inc.
```

```
% Shrink rate.
```

```
s = 3/50;
```

```
sz = 2/50;
```

```
% x,y and z of measurement
```

```
x = meas(1,:);
```

```
y = meas(2,:);
```

```
z = meas(3,:);
```

```
[az,~,r] = cart2sph(x,y,z);
```

```
% Shift x and y position.
```

```
Lshrink = abs(s*r.*(cos(az)));
```

```
Wshrink = abs(s*r.*(sin(az)));
```

```
Hshrink = sz*r;
```

```
shiftX = Lshrink;
```

```
shiftY = Wshrink;
```

```
shiftZ = Hshrink;
```

```
x = x + sign(x).*shiftX/2;
```

```
y = y + sign(y).*shiftY/2;
```

```
z = z - shiftZ/2;
```

```
pos = [x;y;z];
```

```
posCov = measCov(1:3,1:3,:);
```

```
yaw = meas(4,:);
```

```
yawCov = measCov(4,4,:);
```

```
% Dimensions are initialized for a standard passenger car with low
% uncertainty.
```

```
dim = [4.7;1.8;1.4];
```

```
dimCov = 0.01*eye(3);
```

```
end
```

### HelperBoundingBoxDetector

This is the supporting class HelperBoundingBoxDetector to accept a point cloud input and return a list of objectDetection

```

classdef HelperBoundingBoxDetector < matlab.System
    % HelperBoundingBoxDetector A helper class to segment the point cloud
    % into bounding box detections.
    % The step call to the object does the following things:
    %
    % 1. Removes point cloud outside the limits.
    % 2. From the survived point cloud, segments out ground
    % 3. From the obstacle point cloud, forms clusters and puts bounding
    %    box on each cluster.

    % Cropping properties
    properties
        % XLimits XLimits for the scene
        XLimits = [-70 70];
        % YLimits YLimits for the scene
        YLimits = [-6 6];
        % ZLimits ZLimits fot the scene
        ZLimits = [-2 10];
    end

    % Ground Segmentation Properties
    properties
        % GroundMaxDistance Maximum distance of point to the ground plane
        GroundMaxDistance = 0.3;
        % GroundReferenceVector Reference vector of ground plane
        GroundReferenceVector = [0 0 1];
        % GroundMaxAngularDistance Maximum angular distance of point to reference vector
        GroundMaxAngularDistance = 5;
    end

    % Bounding box Segmentation properties
    properties
        % SegmentationMinDistance Distance threshold for segmentation
        SegmentationMinDistance = 1.6;
        % MinDetectionsPerCluster Minimum number of detections per cluster
        MinDetectionsPerCluster = 2;
        % MaxZDistanceCluster Maximum Z-coordinate of cluster
        MaxZDistanceCluster = 3;
        % MinZDistanceCluster Minimum Z-coordinate of cluster
        MinZDistanceCluster = -3;
    end

    % Ego vehicle radius to remove ego vehicle point cloud.
    properties
        % EgoVehicleRadius Radius of ego vehicle
        EgoVehicleRadius = 3;
    end

    properties
        % MeasurementNoise Measurement noise for the bounding box detection
        MeasurementNoise = blkdiag(eye(3),10,eye(3));
    end

    properties (Nontunable)
        MeasurementParameters = struct.empty(0,1);
    end
end

```

```

methods
    function obj = HelperBoundingBoxDetector(varargin)
        setProperties(obj,nargin,varargin{:})
    end
end

methods (Access = protected)
    function [bboxDets,obstacleIndices,groundIndices,croppedIndices] = stepImpl(obj,currentPointCloud)
        % Crop point cloud
        [pcSurvived,survivedIndices,croppedIndices] = cropPointCloud(currentPointCloud,obj.XL)
        % Remove ground plane
        [pcObstacles,obstacleIndices,groundIndices] = removeGroundPlane(pcSurvived,obj.GroundPlane)
        % Form clusters and get bounding boxes
        detBBoxes = getBoundingBoxes(pcObstacles,obj.SegmentationMinDistance,obj.MinDetectionDistance)
        % Assemble detections
        if isempty(obj.MeasurementParameters)
            measParams = {};
        else
            measParams = obj.MeasurementParameters;
        end
        bboxDets = assembleDetections(detBBoxes,obj.MeasurementNoise,measParams,time);
    end
end
end

function detections = assembleDetections(bboxes,measNoise,measParams,time)
% This method assembles the detections in objectDetection format.
numBoxes = size(bboxes,2);
detections = cell(numBoxes,1);
for i = 1:numBoxes
    detections{i} = objectDetection(time,cast(bboxes(:,i),'double'),...
        'MeasurementNoise',double(measNoise),'ObjectAttributes',struct,...
        'MeasurementParameters',measParams);
end
end

function bboxes = getBoundingBoxes(ptCloud,minDistance,minDetsPerCluster,maxZDistance,minZDistance)
% This method fits bounding boxes on each cluster with some basic
% rules.
% Cluster must have at least minDetsPerCluster points.
% Its mean z must be between maxZDistance and minZDistance.
% length, width and height are calculated using min and max from each
% dimension.
[labels,numClusters] = pcsegdist(ptCloud,minDistance);
pointData = ptCloud.Location;
bboxes = nan(7,numClusters,'like',pointData);
isValidCluster = false(1,numClusters);
for i = 1:numClusters
    thisPointData = pointData(labels == i,:);
    meanPoint = mean(thisPointData,1);
    if size(thisPointData,1) > minDetsPerCluster && ...
        meanPoint(3) < maxZDistance && meanPoint(3) > minZDistance
        cuboid = pcfitcuboid(pointCloud(thisPointData));
        yaw = cuboid.Orientation(3);
        L = cuboid.Dimensions(1);
        W = cuboid.Dimensions(2);
        H = cuboid.Dimensions(3);
        if abs(yaw) > 45

```

```

        possibles = yaw + [-90;90];
        [~,toChoose] = min(abs(possibles));
        yaw = possibles(toChoose);
        temp = L;
        L = W;
        W = temp;
    end
    bboxes(:,i) = [cuboid.Center yaw L W H]';
    isValidCluster(i) = L < 20 & W < 20;
end
end
bboxes = bboxes(:,isValidCluster);
end

function [ptCloudOut,obstacleIndices,groundIndices] = removeGroundPlane(ptCloudIn,maxGroundDist,
% This method removes the ground plane from point cloud using
% pcfiteplane.
[~,groundIndices,outliers] = pcfiteplane(ptCloudIn,maxGroundDist,referenceVector,maxAngularDi
ptCloudOut = select(ptCloudIn,outliers);
obstacleIndices = currentIndices(outliers);
groundIndices = currentIndices(groundIndices);
end

function [ptCloudOut,indices,croppedIndices] = cropPointCloud(ptCloudIn,xLim,yLim,zLim,egoVehicle
% This method selects the point cloud within limits and removes the
% ego vehicle point cloud using findNeighborsInRadius
locations = ptCloudIn.Location;
locations = reshape(locations,[],3);
insideX = locations(:,1) < xLim(2) & locations(:,1) > xLim(1);
insideY = locations(:,2) < yLim(2) & locations(:,2) > yLim(1);
insideZ = locations(:,3) < zLim(2) & locations(:,3) > zLim(1);
inside = insideX & insideY & insideZ;

% Remove ego vehicle
nearIndices = findNeighborsInRadius(ptCloudIn,[0 0 0],egoVehicleRadius);
nonEgoIndices = true(ptCloudIn.Count,1);
nonEgoIndices(nearIndices) = false;
validIndices = inside & nonEgoIndices;
indices = find(validIndices);
croppedIndices = find(~validIndices);
ptCloudOut = select(ptCloudIn,indices);
end

```

### **mexLidarTracker**

This function implements the point cloud preprocessing display and the tracking algorithm using a functional interface for code generation.

```

function [detections,obstacleIndices,groundIndices,croppedIndices,...
confirmedTracks, modelProbs] = mexLidarTracker(ptCloudLocations,time)

```

```

persistent detectorModel tracker detectableTracksInput currentNumTracks

```



```

if isempty(detectorModel) || isempty(tracker) || isempty(detectableTracksInput) || isempty(currentNumTracks)

    % Use the same starting seed as MATLAB to reproduce results in SIL
    % simulation.
    rng(2018);

    % A bounding box detector model.
    detectorModel = HelperBoundingBoxDetector(...
        'XLimits',[-50 75],...           % min-max
        'YLimits',[-5 5],...             % min-max
        'ZLimits',[-2 5],...             % min-max
        'SegmentationMinDistance',1.8,... % minimum Euclidian distance
        'MinDetectionsPerCluster',1,...  % minimum points per cluster
        'MeasurementNoise',blkdiag(0.25*eye(3),25,eye(3)),... % measurement noise
        'GroundMaxDistance',0.3);        % maximum distance of ground points from

    assignmentGate = [75 1000]; % Assignment threshold;
    confThreshold = [7 10];     % Confirmation threshold for history logic
    delThreshold = [8 10];     % Deletion threshold for history logic
    Kc = 1e-9;                 % False-alarm rate per unit volume

    filterInitFcn = @helperInitIMMFilter;

    tracker = trackerJPDA('FilterInitializationFcn',filterInitFcn,...
        'TrackLogic','History',...
        'AssignmentThreshold',assignmentGate,...
        'ClutterDensity',Kc,...
        'ConfirmationThreshold',confThreshold,...
        'DeletionThreshold',delThreshold,...
        'HasDetectableTrackIDsInput',true,...
        'InitializationThreshold',0,...
        'MaxNumTracks',30,...
        'HitMissThreshold',0.1);

    detectableTracksInput = zeros(tracker.MaxNumTracks,2);

    currentNumTracks = 0;
end

ptCloud = pointCloud(ptCloudLocations);

% Detector model
[detections,obstacleIndices,groundIndices,croppedIndices] = detectorModel(ptCloud,time);

% Call tracker
[confirmedTracks,~,allTracks] = tracker(detections,time,detectableTracksInput(1:currentNumTracks));
% Update the detectability input
currentNumTracks = numel(allTracks);
detectableTracksInput(1:currentNumTracks,:) = helperCalcDetectability(allTracks,[1 3 6]);

% Get model probabilities
modelProbs = zeros(2,numel(confirmedTracks));
if isLocked(tracker)
    for k = 1:numel(confirmedTracks)
        c1 = getTrackFilterProperties(tracker,confirmedTracks(k).TrackID,'ModelProbabilities');
        probs = c1{1};
        modelProbs(1,k) = probs(1);
        modelProbs(2,k) = probs(2);
    end
end

```

```
    end  
end  
  
end
```

### **helperCalcDetectability**

The function calculates the probability of detection for each track. This function is used to generate the "DetectableTracksIDs" input for the `trackerJPDA`.

```
function detectableTracksInput = helperCalcDetectability(tracks,posIndices)  
% This is a helper function to calculate the detection probability of  
% tracks for the lidar tracking example. It may be removed in a future  
% release.  
  
% Copyright 2019 The MathWorks, Inc.  
  
% The bounding box detector has low probability of segmenting point clouds  
% into bounding boxes are distances greater than 40 meters. This function  
% models this effect using a state-dependent probability of detection for  
% each tracker. After a maximum range, the Pd is set to a high value to  
% enable deletion of track at a faster rate.  
if isempty(tracks)  
    detectableTracksInput = zeros(0,2);  
    return;  
end  
rMax = 75;  
rAmbig = 40;  
stateSize = numel(tracks(1).State);  
posSelector = zeros(3,stateSize);  
posSelector(1,posIndices(1)) = 1;  
posSelector(2,posIndices(2)) = 1;  
posSelector(3,posIndices(3)) = 1;  
pos = getTrackPositions(tracks,posSelector);  
if coder.target('MATLAB')  
    trackIDs = [tracks.TrackID];  
else  
    trackIDs = zeros(1,numel(tracks),'uint32');  
    for i = 1:numel(tracks)  
        trackIDs(i) = tracks(i).TrackID;  
    end  
end  
[~,~,r] = cart2sph(pos(:,1),pos(:,2),pos(:,3));  
probDetection = 0.9*ones(numel(tracks),1);  
probDetection(r > rAmbig) = 0.4;  
probDetection(r > rMax) = 0.99;  
detectableTracksInput = [double(trackIDs(:)) probDetection(:)];  
end
```

### **loadLidarAndImageData**

Stitches Lidar and Camera data for processing using initial and final time specified.

```
function [lidarData,imageData] = loadLidarAndImageData(datasetFolder,initTime,finalTime)  
initFrame = max(1,floor(initTime*10));
```

```
lastFrame = min(350,ceil(finalTime*10));
load (fullfile(datasetFolder,'imageData_35seconds.mat'),'allImageData');
imageData = allImageData(initFrame:lastFrame);

numFrames = lastFrame - initFrame + 1;
lidarData = cell(numFrames,1);

% Each file contains 70 frames.
initFileIndex = floor(initFrame/70) + 1;
lastFileIndex = ceil(lastFrame/70);

frameIndices = [1:70:numFrames numFrames + 1];

counter = 1;
for i = initFileIndex:lastFileIndex
    startFrame = frameIndices(counter);
    endFrame = frameIndices(counter + 1) - 1;
    load(fullfile(datasetFolder,['lidarData_',num2str(i)]),'currentLidarData');
    lidarData(startFrame:endFrame) = currentLidarData(1:(endFrame + 1 - startFrame));
    counter = counter + 1;
end
end
```

## References

[1] Arya Senna Abdul Rachman, Arya. "3D-LIDAR Multi Object Tracking for Autonomous Driving: Multi-target Detection and Tracking under Urban Road Uncertainties." (2017).

## Build Map from 2-D Lidar Scans Using SLAM

This example shows you how to implement the simultaneous localization and mapping (SLAM) algorithm on a series of 2-D lidar scans using scan processing algorithms and pose graph optimization (PGO). The goal of this example is to estimate the trajectory of the robot and build a map of the environment.

The SLAM algorithm in this example incrementally processes the lidar scans and builds a pose graph to create the map of the environment. To overcome the drift accumulated in estimated robot trajectory, the example recognizes previously visited places through scan matching and utilizes the loop closure information to optimize poses and update the map of the environment. To optimize the pose graph, this example uses 2-D pose graph optimization from Navigation Toolbox™.

In this example, you learn how to:

- Estimate robot trajectory from a series of scans using scan registration algorithms.
- Optimize the drift in estimated robot trajectory by identifying previously visited places (loop closures).
- Visualize the map of the environment using scans and their absolute poses.

### Load Laser Scans

This example uses data collected in an indoor environment using a Jackal™ robot from Clearpath Robotics™. The robot is equipped with a SICK™ TiM-511 laser scanner with a maximum range of 10 meters. Load the `offlineSlamData.mat` file containing the laser scans into the workspace.

```
data = load('offlineSlamData.mat');
scans = data.scans;
```

### Robot Trajectory Estimation

The example uses the `matchScansGrid` and `matchScans` functions to estimate the relative pose between successive scans. The `matchScansGrid` function provides the initial estimate for the relative pose, which is accurate up to the specified resolution. The `matchScans` function uses the estimate as an initial guess, and refines the relative pose for better estimation.

```
% Set maximum lidar range to be slightly smaller than maximum range of the
% scanner, as the laser readings are less accurate near maximum range
maxLidarRange = 8;
% Set the map resolution to 10 cells per meter, which gives a precision of
% 10cm
mapResolution = 10;
% Create a pose graph object and define information matrix
pGraph = poseGraph;
infoMat = [1 0 0 1 0 1];
% Loop over each scan and estimate relative pose
prevScan = scans{1};
for i = 2:numel(scans)
    currScan = scans{i};
    % Estimate relative pose between current scan and previous scan
    [relPose,stats] = matchScansGrid(currScan,prevScan, ...
        'MaxRange',maxLidarRange,'Resolution',mapResolution);
    % Refine the relative pose
    relPoseRefined = matchScans(currScan,prevScan,'initialPose',relPose);
    % Add relative pose to the pose graph object
```

```

pGraph.addRelativePose(relPoseRefined,infoMat);
ax = show(pGraph,'IDs','off');
title(ax,'Estimated Robot Trajectory')
drawnow
prevScan = currScan;
end

```

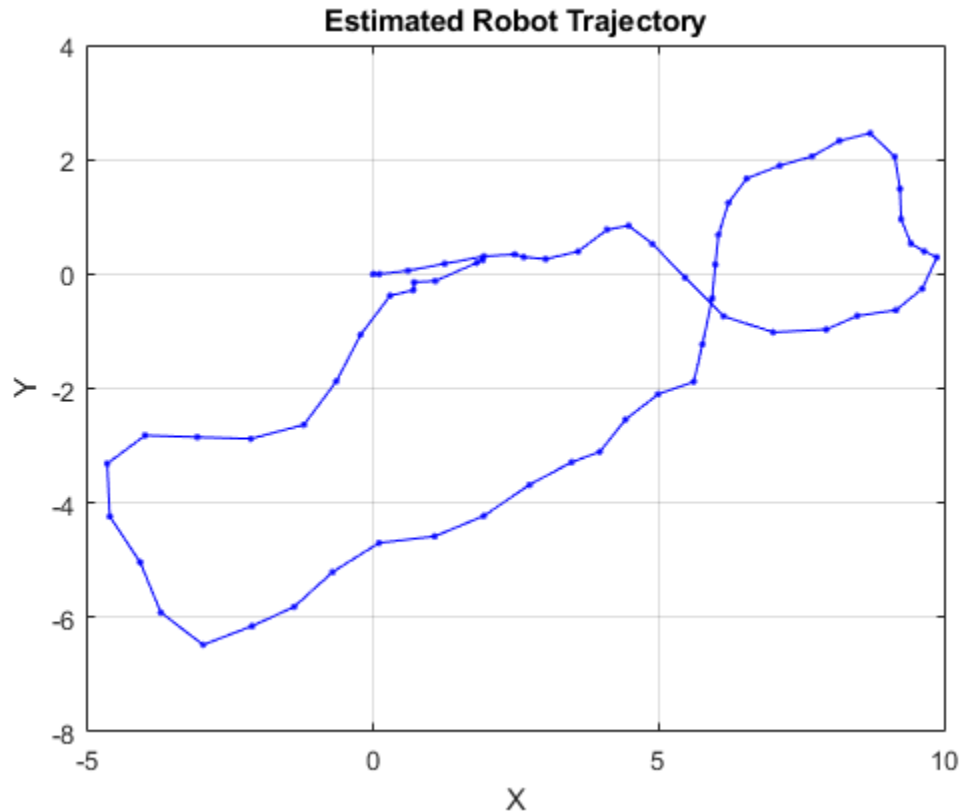

Notice that the estimated robot trajectory drifts over time. The drift can be due to any of the following reasons:

- Noisy scans from the sensor without sufficient overlap
- Absence of significant features
- Inaccurate initial transformation, especially when rotation is significant

The drift in estimated trajectory results in an inaccurate map of the environment. Visualize the map and robot trajectory using the helperShow on page 1-0 helper function, defined in the Supporting Functions on page 1-0 section of this example.

```

hFigMap = figure;
axMap = axes('Parent',hFigMap);
helperShow(scans,pGraph,maxLidarRange,axMap);
title(axMap,'Map of the Environment and Robot Trajectory')

```



### Drift Correction

Correct the drift in trajectory by accurately detecting the *loops*, which are places the robot has previously visited. Add the loop closure edges to the pose graph, which helps to correct the drift in trajectory during pose graph optimization.

### Loop Closure Detection

*Loop closure detection* determines whether the robot has previously visited the current location. The search is performed by matching the current scan against the previous scans around the current robot location, within the radius specified by `loopClosureSearchRadius`. A scan is accepted as a match if the match score is greater than the specified `loopClosureThreshold`. Loop closures are detected using the `helperDetectLoop` helper function, which is attached to this example as a supporting file.

Adjust the loop closure parameters based on the quality of your results. You can increase the `loopClosureThreshold` value to reject false positives in loop closure detection, but the function might still return bad matches in environments with similar or repeated features. To address this, increase the `loopClosureSearchRadius` value to search a larger radius around the current pose estimate for loop closures, though this increases computation time.

```
loopClosureThreshold = 110;  
loopClosureSearchRadius = 2;  
[loopClosureEdgeIds,loopClosurePoses] = helperDetectLoop(scans,pGraph, ...  
    loopClosureSearchRadius,loopClosureThreshold);
```

## Trajectory Optimization

Add the detected loop closure edges to the pose graph to correct the drift in the estimated trajectory. Use the `optimizePoseGraph` (Navigation Toolbox) function to optimize the pose graph.

```
% Add loop closure edges to pose graph
if ~isempty(loopClosureEdgeIds)
    for k = 1:size(loopClosureEdgeIds,1)
        pGraph.addRelativePose(loopClosurePoses(k,:),infoMat, ...
            loopClosureEdgeIds(k,1),loopClosureEdgeIds(k,2));
    end
end
% Optimize pose graph
updatedPGraph = optimizePoseGraph(pGraph);
```

## Visualization

Visualize the change in robot trajectory before and after pose graph optimization. The red lines represent loop closure edges.

```
hFigTraj = figure('Position',[0 0 900 450]);

% Visualize robot trajectory before optimization
axPGraph = subplot(1,2,1,'Parent',hFigTraj);
axPGraph.Position = [0.04 0.1 0.45 0.8];
show(pGraph,'IDs','off','Parent',axPGraph);
title(axPGraph,'Before PGO')

% Visualize robot trajectory after optimization
axUpdatedPGraph = subplot(1,2,2,'Parent',hFigTraj);
axUpdatedPGraph.Position = [0.54 0.1 0.45 0.8];
show(updatedPGraph,'IDs','off','Parent',axUpdatedPGraph);
title(axUpdatedPGraph,'After PGO')
axis([axPGraph axUpdatedPGraph],[-6 10 -7 3])
sgtitle('Robot Trajectory','FontWeight','bold')
```

### Robot Trajectory

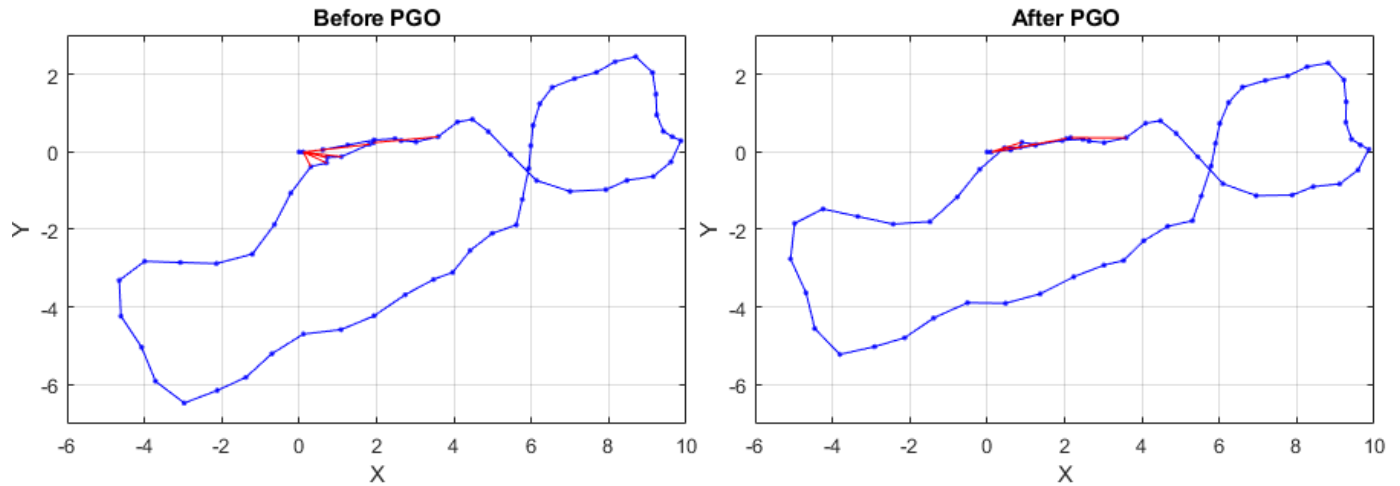

Visualize the map of the environment and robot trajectory before and after pose graph optimization.

```

hFigMapTraj = figure('Position',[0 0 900 450]);

% Visualize map and robot trajectory before optimization
axOldMap = subplot(1,2,1,'Parent',hFigMapTraj);
axOldMap.Position = [0.05 0.1 0.44 0.8];
helperShow(scans,pGraph,maxLidarRange,axOldMap)
title(axOldMap,'Before PGO')

% Visualize map and robot trajectory after optimization
axUpdatedMap = subplot(1,2,2,'Parent',hFigMapTraj);
axUpdatedMap.Position = [0.56 0.1 0.44 0.8];
helperShow(scans,updatedPGraph,maxLidarRange,axUpdatedMap)
title(axUpdatedMap,'After PGO')
axis([axOldMap axUpdatedMap],[-9 18 -10 9])
sgtitle('Map of the Environment and Robot Trajectory','FontWeight','bold')
    
```



## Map of the Environment and Robot Trajectory

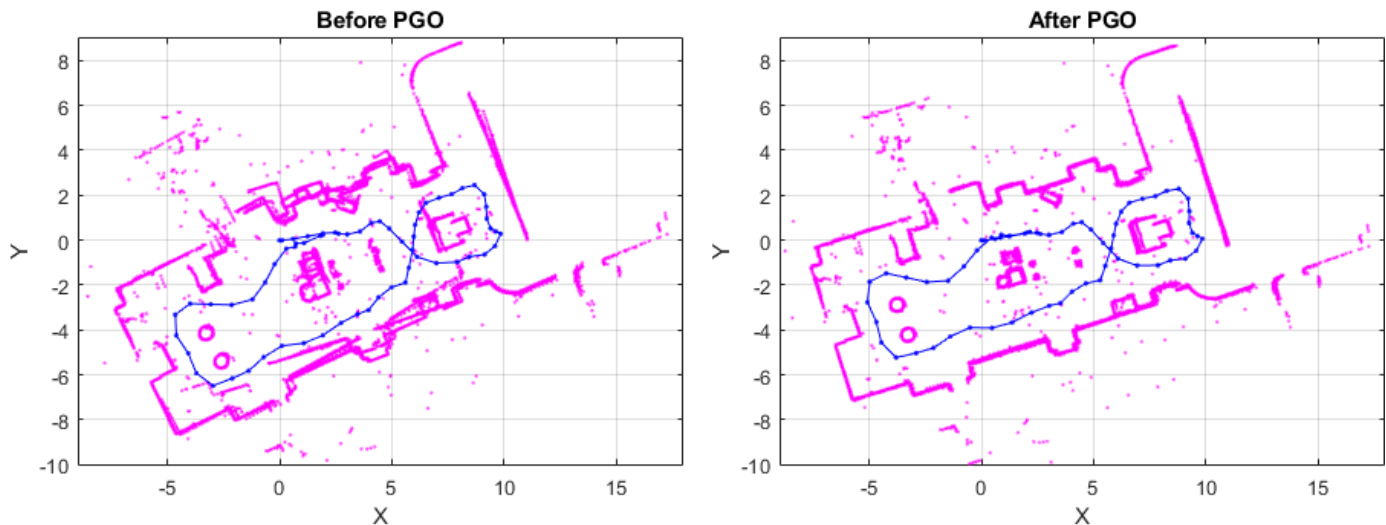

### Supporting Functions

The `helperShow` helper function visualizes the map of the environment and trajectory of the robot. The function transforms lidar scans using their corresponding poses to create a map of the environment.

```
function helperShow(scans,pGraph,maxRange,ax)
    hold(ax,'on')
    for i = 1:numel(scans)
        sc = transformScan(scans{i}.removeInvalidData('RangeLimits',[0.02 maxRange]), ...
            pGraph.nodes(i));
        scPoints = sc.Cartesian;
        plot(ax,scPoints(:,1),scPoints(:,2),'.','MarkerSize',3,'color','m')
    end
    nds = pGraph.nodes;
    plot(ax,nds(:,1),nds(:,2),'-','MarkerSize',5,'color','b')
    hold(ax,'off')
    axis(ax,'equal')
    box(ax,'on')
    grid(ax,'on')
    xlabel('X')
    ylabel('Y')
end
```

### See Also

#### Functions

[matchScansGrid](#) | [matchScans](#) | [addRelativePose](#) (Navigation Toolbox) | [show](#) (Navigation Toolbox) | [optimizePoseGraph](#) (Navigation Toolbox)

**Objects**

lidarScan | poseGraph (Navigation Toolbox)

## Terrain Classification for Aerial Lidar Data

This example shows you how to segment and classify terrain in aerial lidar data as ground, building, and vegetation. The example uses a LAZ file captured by an airborne lidar system as input. First, classify the point cloud data in the LAZ file into ground and non-ground points. Then, further classify non-ground points into building and vegetation points based on normals and curvature features. This figure provides an overview of the process.

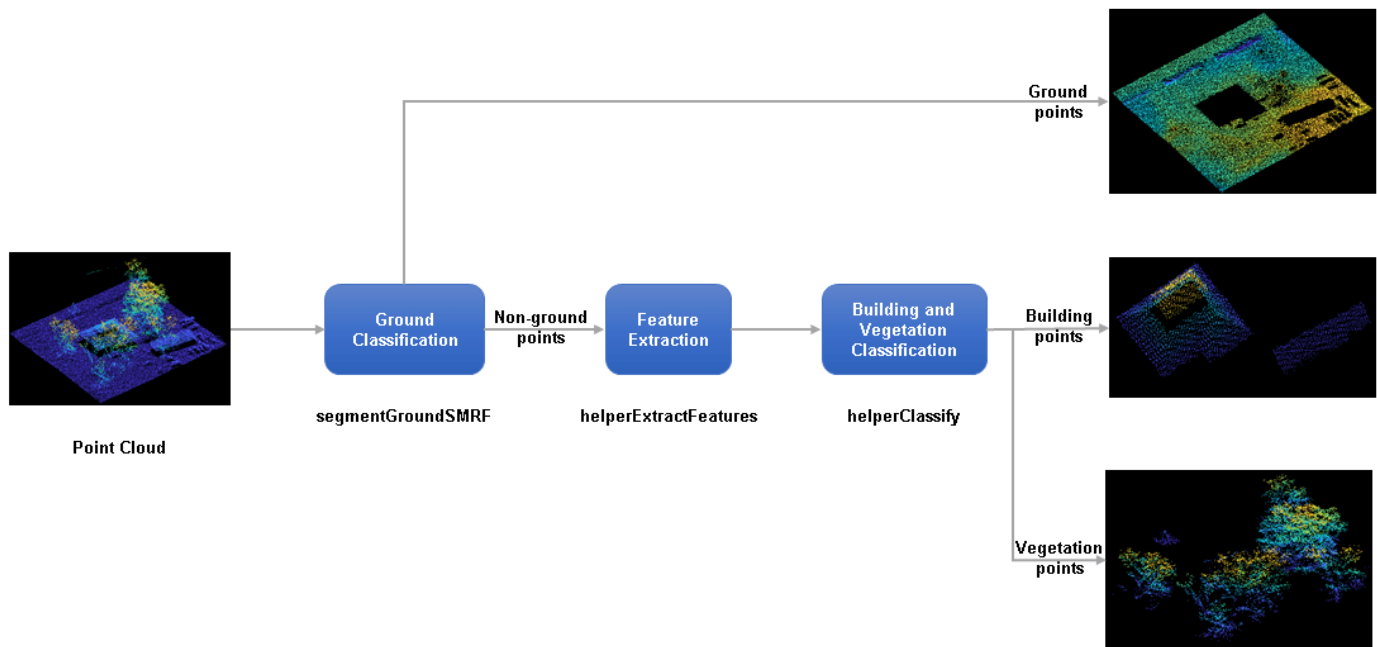

### Load and Visualize Data

Load the point cloud data and corresponding ground truth labels from the LAZ file, `aerialLidarData.laz`, obtained from the Open Topography Dataset [1] on page 1-0 . The point cloud consists of various classes, including ground, building, and vegetation. Load the point cloud data and the corresponding ground truth labels into the workspace using the `readPointCloud` object function of the `lasFileReader` object. Visualize the point cloud, color-coded according to the ground truth labels, using the `pcshow` function.

```
lazfile = fullfile(toolboxdir('lidar'),'lidardata','las','aerialLidarData.laz');
% Read LAZ data from file
lazReader = lasFileReader(lazfile);
% Read point cloud and corresponding ground truth labels
[ptCloud,pointAttributes] = readPointCloud(lazReader, ...
    'Attributes','Classification');
grdTruthLabels = pointAttributes.Classification;
% Visualize the input point cloud with corresponding ground truth labels
figure
pcshow(ptCloud.Location,grdTruthLabels)
title('Aerial Lidar Data with Ground Truth')
```

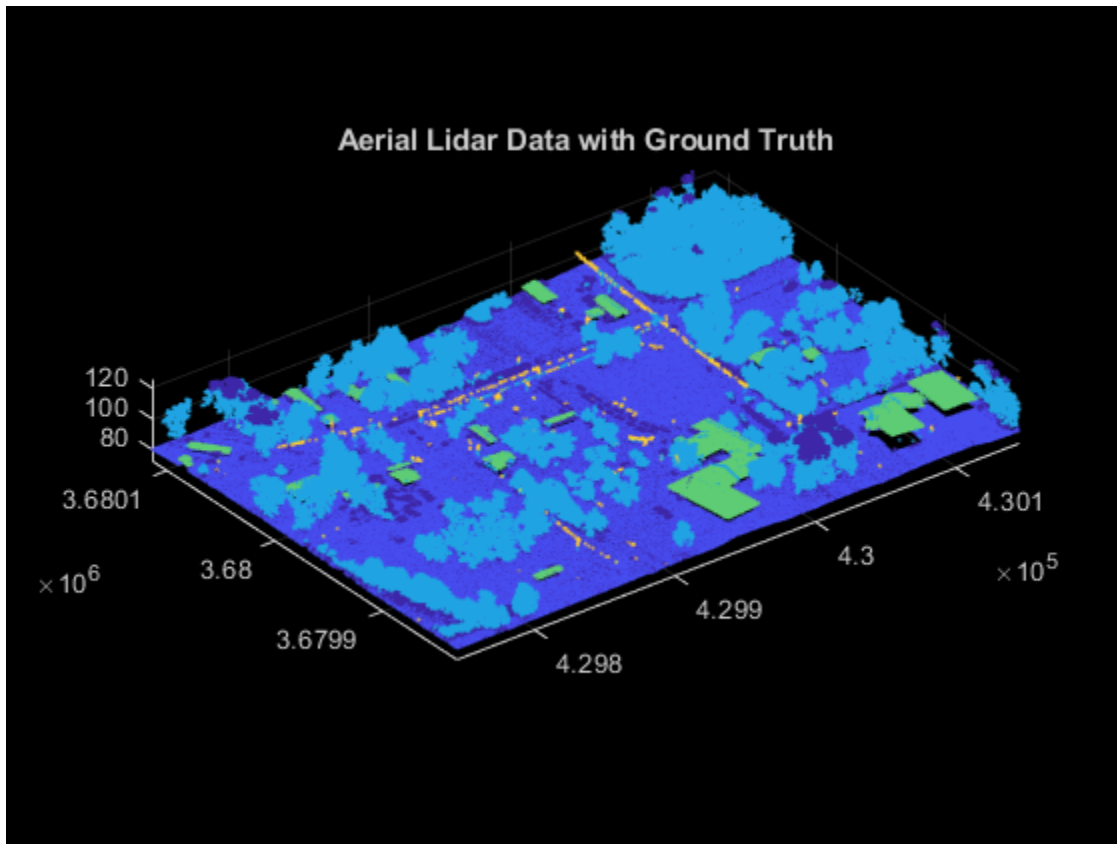

### Ground Classification

*Ground classification* is a preprocessing step to segment the input point cloud as ground and non-ground. Segment the data loaded from the LAZ file into ground and non-ground points using the `segmentGroundSMRF` function.

```
[groundPtsIdx,nonGroundPtCloud,groundPtCloud] = segmentGroundSMRF(ptCloud);  
% Visualize ground and non-ground points in green and magenta, respectively  
figure  
pcshowpair(nonGroundPtCloud,groundPtCloud)  
title('Classified Ground and Non-Ground Points')
```

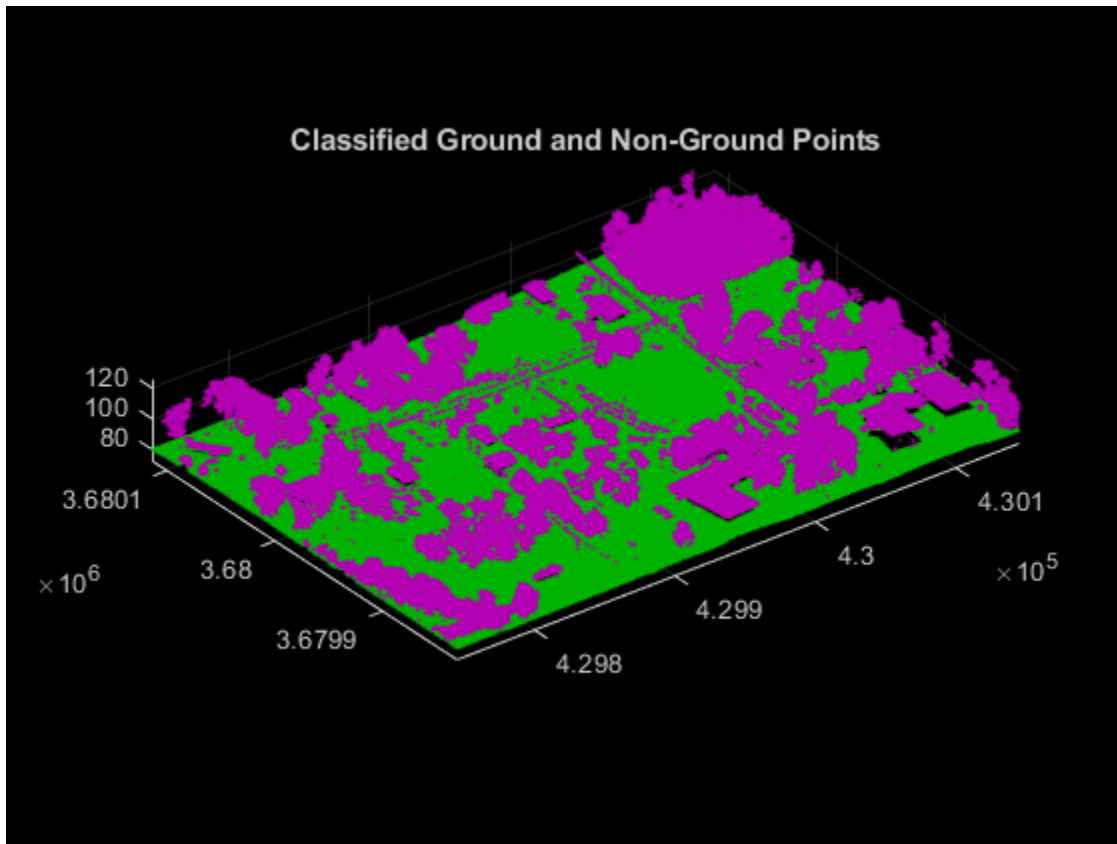

### Feature Extraction

Extract features from the point cloud using the `helperExtractFeatures` function. All the helper functions are attached to this example as supporting files. The helper function estimates the normal and curvature values for each point in the point cloud. These features provide underlying structure information at each point by correlating it with the points in its neighborhood.

You can specify the number of neighbors to consider. If the number of neighbors is too low, the helper function overclusters vegetation points. If the number of neighbors is too high, there is no defining boundary between buildings and vegetation, as vegetation points near the building points are misclassified.

```
neighbors = 10;
[normals,curvatures,neighInds] = helperExtractFeatures(nonGroundPtCloud, ...
    neighbors);
```

### Building and Vegetation Classification

The helper function uses the variation in normals and curvature to distinguish between buildings and vegetation. The buildings are more planar compared to vegetation, so the change in curvature and the relative difference of normals between neighbors is less for points belonging to buildings. Vegetation points are more scattered, which results in a higher change in curvatures as compared to buildings. The `helperClassify` function classifies the non-ground points into building and vegetation. The helper function classifies the points as building based on the following criteria:

- The curvature of each point must be small, within the specified curvature threshold, `curveThresh`.

- The neighboring points must have similar normals. The cosine similarity between neighboring normals must be greater than the specified normal threshold, `normalThresh`.

The points that do not satisfy the above criteria are marked as vegetation. The helper function labels the points belonging to vegetation as 1 and building as 2.

```
% Specify the normal threshold and curvature threshold
normalThresh = 0.85;
curveThresh = 0.02;
% Classify the points into building and vegetation
labels = helperClassify(normals,curvatures,neighInds, ...
    normalThresh,curveThresh);
```

Extract the building and vegetation class labels from the ground truth label data. As the LAZ file has many classes, you must first isolate the ground, building and vegetation classes. The classification labels are in compliance with the ASPRS standard for LAZ file formats.

- Classification Value 2 — Represents ground points
- Classification Values 3, 4, and 5 — Represent low, medium, and high vegetation points
- Classification Value 6 — Represents building points

Define `maskData` to extract points belonging to the ground, buildings, and vegetation from the input point cloud.

```
maskData = grdTruthLabels>=2 & grdTruthLabels<=6;
```

Modify the ground truth labels of the input point cloud, specified as `grdTruthLabels`.

```
% Compress low, medium, and high vegetation to a single value
grdTruthLabels(grdTruthLabels>=3 & grdTruthLabels<=5) = 4;
% Update grdTruthLabels for metrics calculation
grdTruthLabels(grdTruthLabels == 2) = 1;
grdTruthLabels(grdTruthLabels == 4) = 2;
grdTruthLabels(grdTruthLabels == 6) = 3;
```

Store the predicted labels acquired from previous classification steps in `estimatedLabels`.

```
estimatedLabels = zeros(ptCloud.Count,1);
estimatedLabels(groundPtsIdx) = 1;
estimatedLabels(labels == 1) = 2;
estimatedLabels(labels == 2) = 3;
```

Extract the labels belonging to ground, buildings, and vegetation.

```
grdTruthLabels = grdTruthLabels(maskData);
estimatedLabels = estimatedLabels(maskData);
```

Visualize the terrain with the ground truth and estimated labels.

```
ptCloud = select(ptCloud,maskData);
hFig = figure('Position',[0 0 900 400]);
axMap1 = subplot(1,2,1,'Color','black','Parent',hFig);
axMap1.Position = [0 0.2 0.5 0.55];
pcshow(ptCloud.Location,grdTruthLabels,'Parent',axMap1)
axis off
title(axMap1,'Aerial Lidar Data with Ground Truth Labels')
axMap2 = subplot(1,2,2,'Color','black','Parent',hFig);
```

```
axMap2.Position = [0.5,0.2,0.5,0.55];
pcshow(ptCloud.Location,estimatedLabels,'Parent',axMap2)
axis off
title(axMap2,'Aerial Lidar Data with Classified Labels')
```

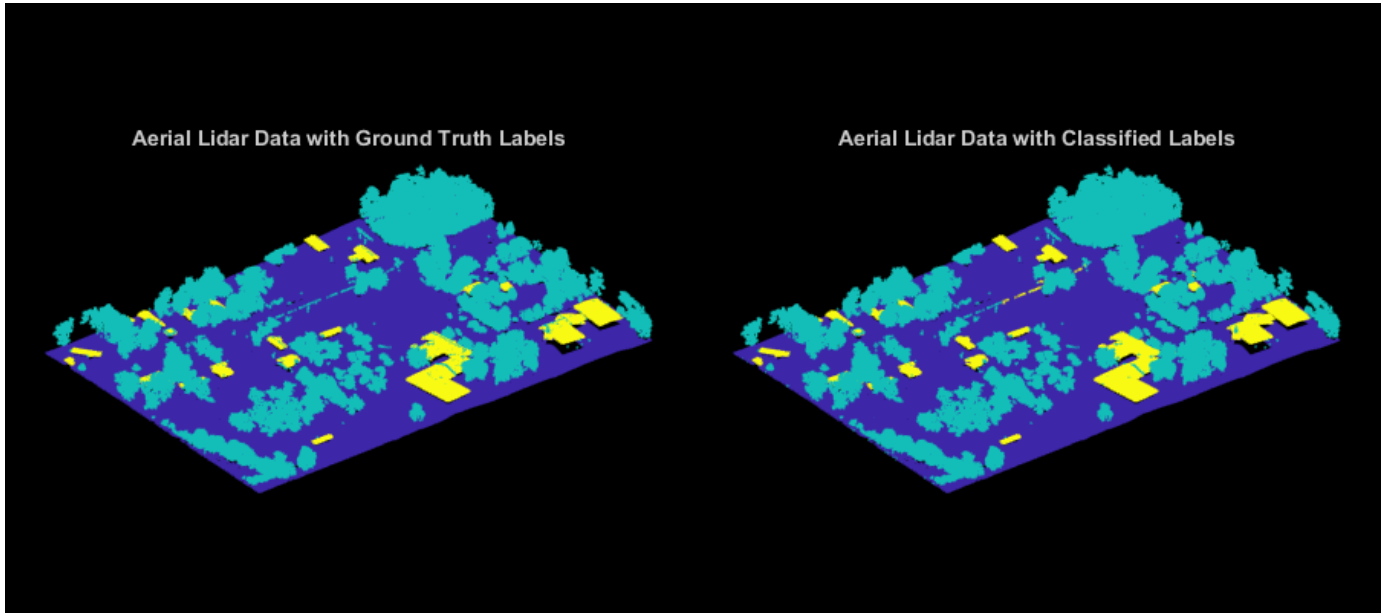

## Validation

Validate the classification by computing the total accuracy on the given point cloud along with the class accuracy, intersection-over-union (IoU), and weighted IoU.

```
confusionMatrix = segmentationConfusionMatrix(estimatedLabels,double(grdTruthLabels));
ssm = evaluateSemanticSegmentation({confusionMatrix}, ...
    {'Ground' 'Vegetation' 'Building'},'Verbose',0);
disp(ssm.DataSetMetrics)
```

GlobalAccuracy	MeanAccuracy	MeanIoU	WeightedIoU
0.99769	0.99608	0.98233	0.99547

```
disp(ssm.ClassMetrics)
```

	Accuracy	IoU
Ground	0.99995	0.99995
Vegetation	0.99079	0.99008
Building	0.99751	0.95696

## See Also

### Functions

readPointCloud | segmentGroundSMRF | pcnormals | pcshow | pcshowpair |  
segmentationConfusionMatrix | evaluateSemanticSegmentation

**Objects**

lasFileReader

**References**

[1] Starr, Scott. "Tuscaloosa, AL: Seasonal Inundation Dynamics and Invertebrate Communities." National Center for Airborne Laser Mapping, December 1, 2011. OpenTopography (<https://doi.org/10.5069/G9SF2T3K>)



## Data Augmentations for Lidar Object Detection Using Deep Learning

This example shows how to perform typical data augmentation techniques for 3-D object detection workflows with lidar data.

Lidar object detection methods predict 3-D bounding boxes around the objects of interest. Data augmentation methods help you avoid overfitting issues while training and also improve the detection accuracy. This example covers global and local augmentation techniques: global augmentation applies to the entire point cloud of a scene and local augmentation techniques applies only to the points belonging to individual objects in a scene.

### Load Data

Extract the ZIP file attached to this example to the temp directory. The ZIP file contains `sampleWPIPointClouds` folder that holds the point clouds and `sampleWPILabels.mat` file that holds the ground truth labels.

```
unzip("sampleWPIPointClouds.zip",tempdir);
dataLocation = fullfile(tempdir,"sampleWPIPointClouds");
```

Create a file datastore to load PCD files using the `pcread` function.

```
lds = fileDatastore(dataLocation,"ReadFcn",@(x) pcread(x));
```

Create a box label datastore to load the 3-D ground truth bounding boxes.

```
load("sampleWPILabels.mat","trainLabels")
bds = boxLabelDatastore(trainLabels);
```

Use the `combine` function to combine the point clouds and 3-D bounding boxes into a single datastore.

```
cds = combine(lds,bds);
```

Read the point cloud and corresponding ground truth label from datastore and display.

```
inputData = read(cds);
ptCloud = inputData{1,1};
gtLabels = inputData{1,2};
figure;
ax = pcshow(ptCloud.Location);
```

Draw the 3-D bounding boxes over the point cloud.

```
showShape("cuboid",gtLabels,"Parent",ax,"Opacity",0.1, ...
"Color","green","LineWidth",0.5);
zoom(ax,2);
```

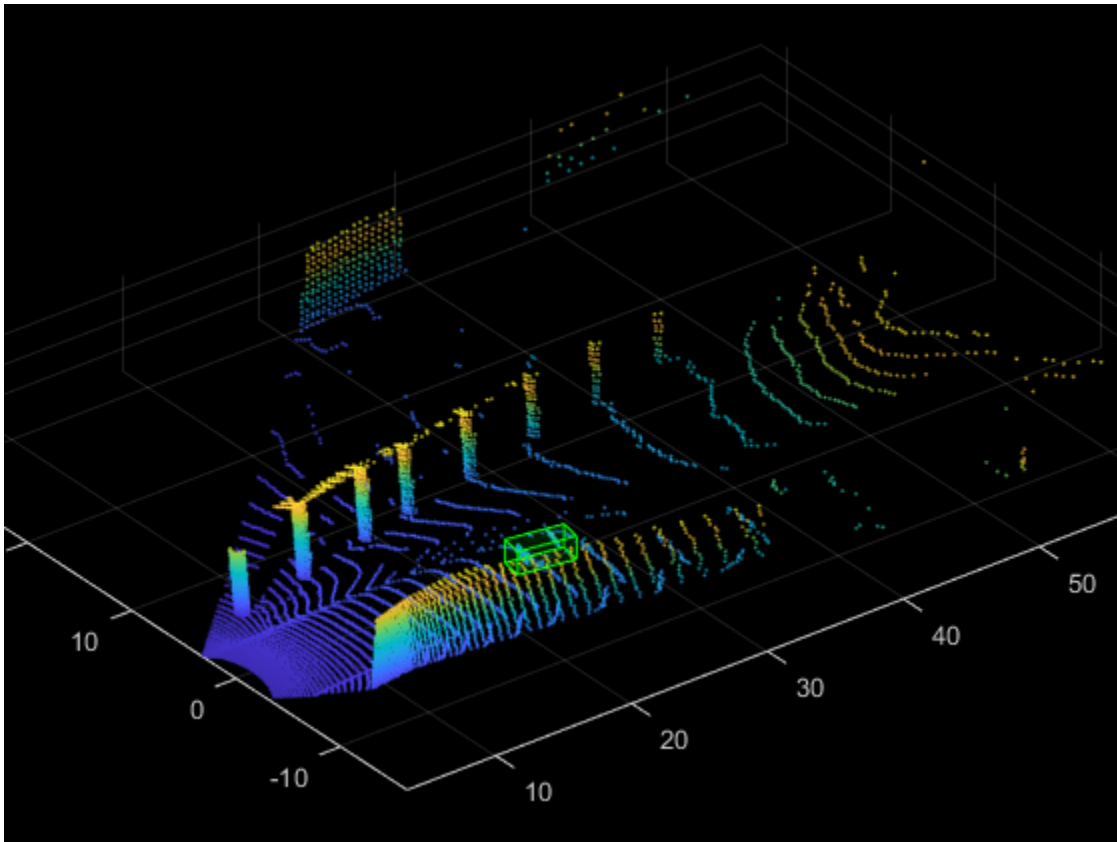

```
reset(cds);
```

### Global Data Augmentation

Global data augmentation techniques are used when the point clouds in a dataset have little variation. A global technique applies transformation to the entire point cloud and generates new point cloud samples. It applies the same transformation to all corresponding ground truth boxes. The following four global data augmentation techniques are commonly used [1 on page 1-0 ].

- 1 Random rotation
- 2 Random scaling
- 3 Random translation
- 4 Random flipping

### Rotate Point Cloud

Randomly rotate the point cloud and the 3-D bounding boxes within the specified range of angles along the z-axis. By doing so, you can simulate data points, such as a vehicle taking a turn. The typical range for rotation is  $[-45\ 45]$  degrees.

Set the random seed for reproducibility.

```
rng(1);
```

Define minimum and maximum yaw angles for rotation.

```
minYawAngle = -45;  
maxYawAngle = 45;
```

Define the grid size to bin the point cloud to.

```
gridSize = [32 32 32];
```

Define the limits of the region of interest within the point cloud.

```
axisLimits = [-100 100];
```

Create an output view for the affine transformation.

```
outView = imref3d(gridSize,axisLimits,axisLimits,axisLimits);
```

Calculate a random angle from the specified yaw angle range.

```
theta = minYawAngle + rand*(maxYawAngle-minYawAngle);
```

Create a transformation that rotates the point clouds and 3-D bounding boxes.

```
tform = randomAffine3d("Rotation",@() deal([0,0,1],theta));
```

Apply the transformation to the point cloud.

```
ptCloudTransformed = pctransform(ptCloud,tform);
```

Apply the same transformation to the 3-D bounding boxes.

```
gtLabelsTranformed = bboxwarp(gtLabels,tform,outView);
```

Display the rotated point cloud and the ground truth boxes.

```
figure;  
ax1 = pcshow(ptCloudTransformed.Location);  
showShape("cuboid",gtLabelsTranformed,"Parent",ax1,"Opacity",0.1, ...  
         "Color","green","LineWidth",0.5);  
zoom(ax1,2);
```

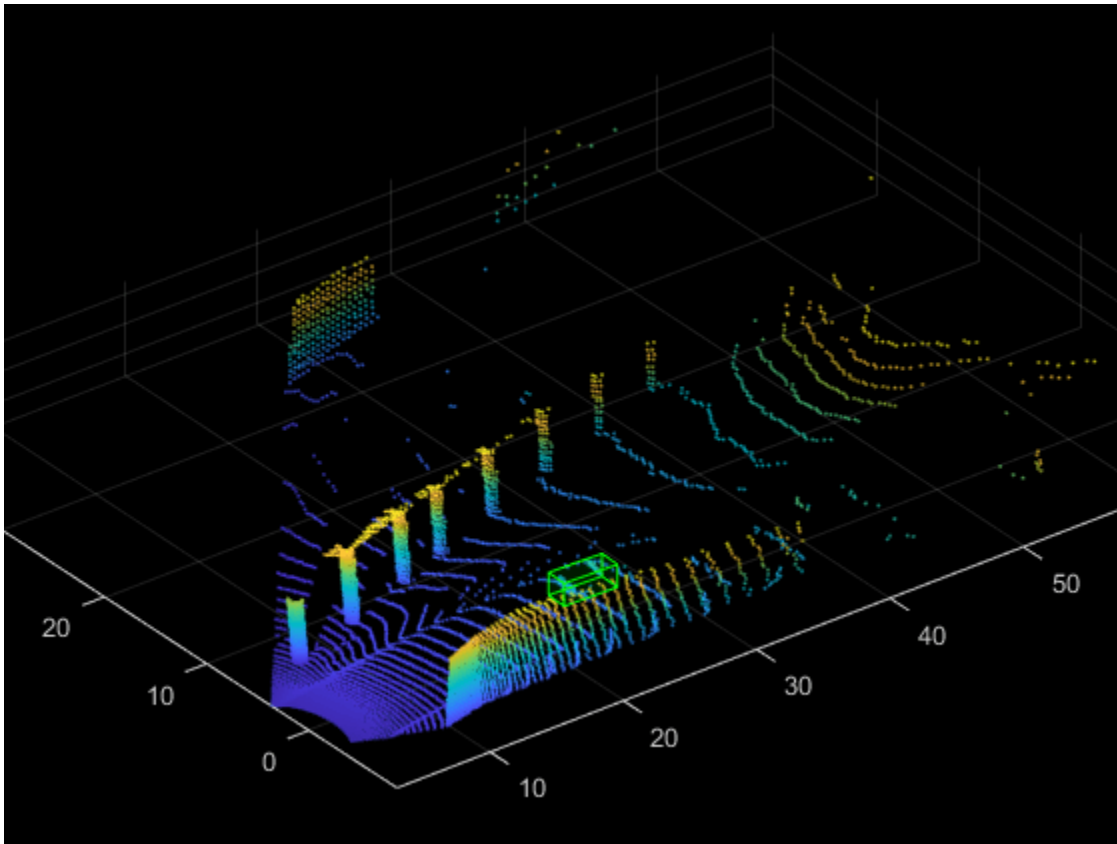

### Scale Point Cloud

Randomly scale the point cloud and the 3-D bounding boxes within the specified range of scales. The typical scaling range is  $[0.95 \ 1.05]$ . The example uses a range of  $[0.5 \ 0.7]$  for better visualization.

Create a transformation to scale the point cloud and 3-D bounding boxes.

```
tform = randomAffine3d("Scale",[0.5 0.7]);
```

Apply the transformation to the point cloud.

```
ptCloudTransformed = pctransform(ptCloud,tform);
```

Apply the same transformation to the 3-D bounding boxes.

```
gtLabelsTranformed = bboxwarp(gtLabels,tform,outView);
```

Display the scaled point cloud and the ground truth boxes.

```
figure;
ax2 = pcshow(ptCloudTransformed.Location);
showShape("cuboid",gtLabelsTranformed,"Parent",ax2,"Opacity",0.1, ...
          "Color","green","LineWidth",0.5);
zoom(ax2,2);
```

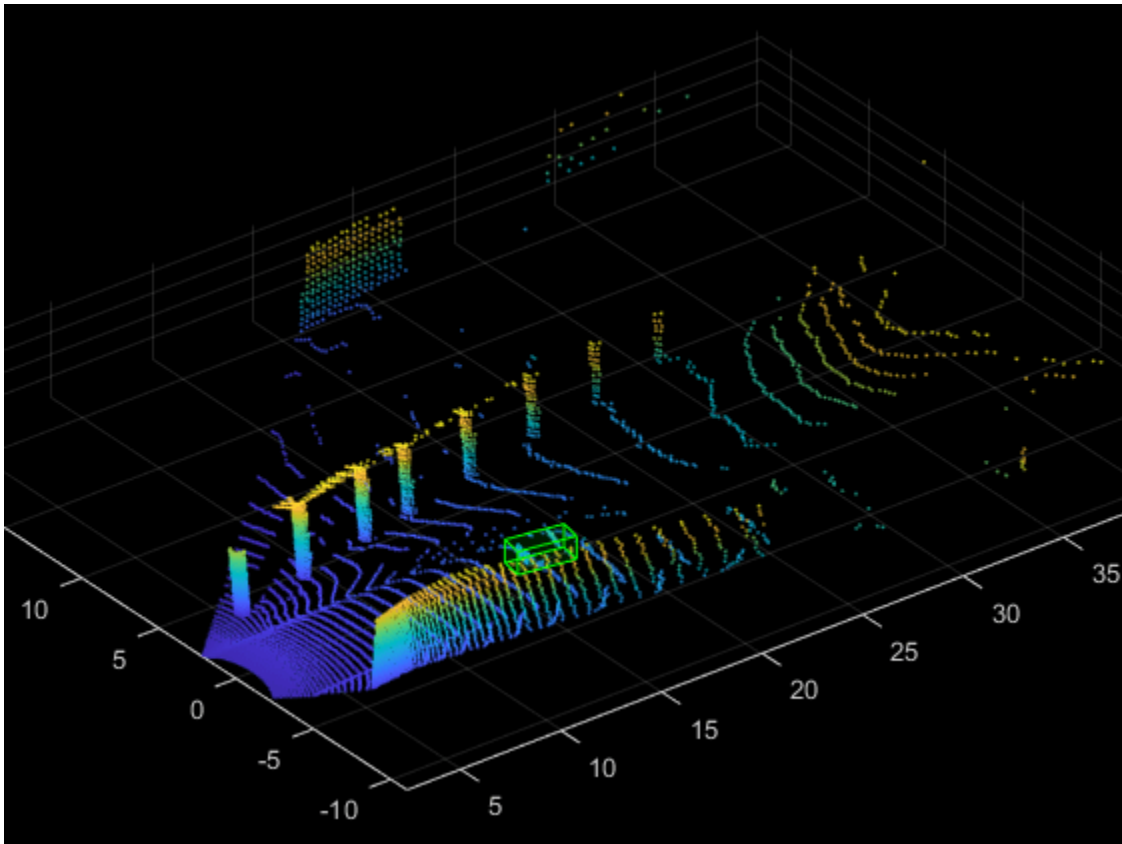

### Translate Point Cloud

Randomly translate the point cloud and the 3-D bounding boxes along the  $x$ -,  $y$ -, and  $z$ -axis within the specified range.

Create a transformation to translate the point cloud and 3-D bounding boxes.

```
tform = randomAffine3d("XTranslation",[0 0.2],...
                      "YTranslation",[0 0.2],...
                      "ZTranslation",[0 0.1]);
```

Apply the transformation to the point cloud.

```
ptCloudTransformed = pctransform(ptCloud,tform);
```

Apply the same transformation to the 3-D bounding boxes.

```
gtLabelsTranformed = bboxwarp(gtLabels,tform,outView);
```

Display the translated point cloud and the ground truth boxes.

```
figure;
ax3 = pcshow(ptCloudTransformed.Location);
showShape("cuboid",gtLabelsTranformed,"Parent",ax3,"Opacity",0.1,"Color",...
          "green","LineWidth",0.5);
zoom(ax3,2);
```

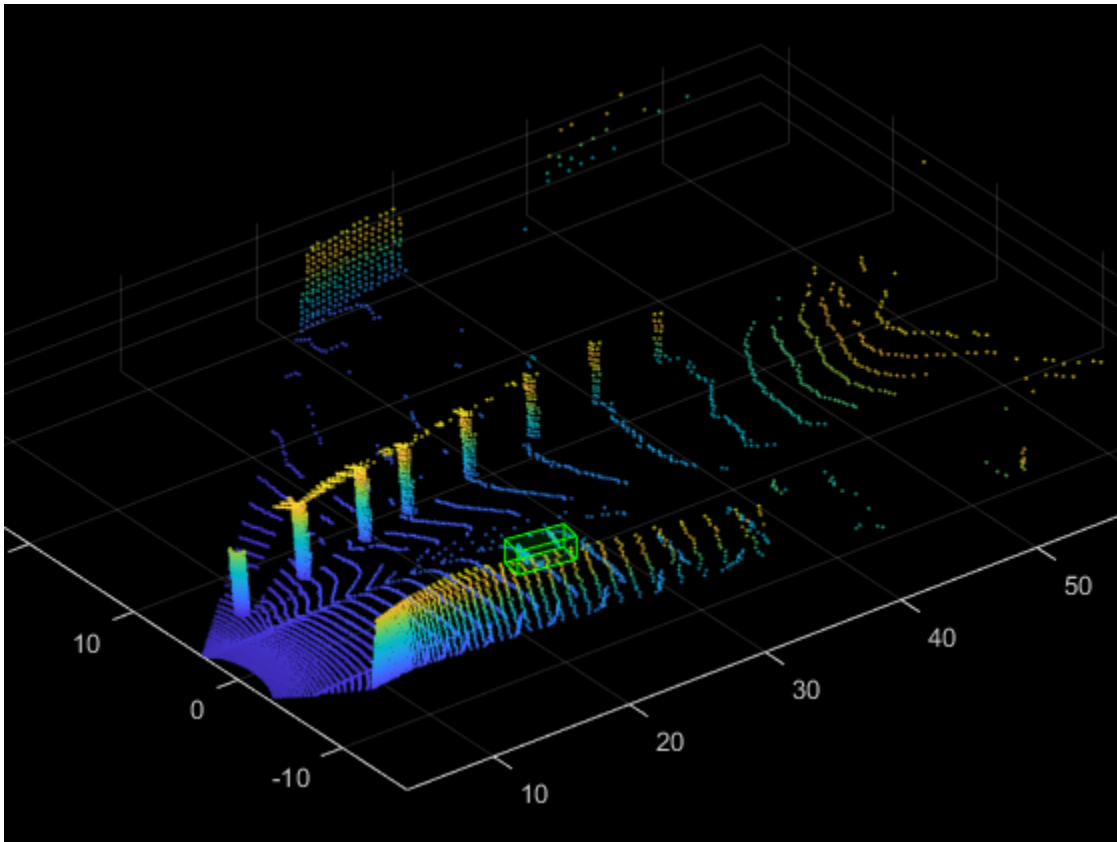

### Flip Along Axis

Randomly flip the point cloud and the 3-D bounding boxes along the y-axis. Do not flip along the x-axis, as the bounding box annotations are provided in the camera field of view.

Create a transformation to flip the point cloud and 3-D bounding boxes.

```
tform = randomAffine3d("YReflection",true);
```

Apply the transformation to the point cloud.

```
ptCloudTransformed = pctransform(ptCloud,tform);
```

Apply the same transformation to the 3-D bounding boxes using the helper function `flipBbox`, attached to this example as a supporting file.

```
gtLabels = flipBbox(gtLabels,tform);
```

Display the flipped point cloud and the ground truth boxes.

```
figure;
ax4 = pcsshow(ptCloudTransformed.Location);
showShape("cuboid",gtLabels,"Parent",ax4,"Opacity",0.1, ...
          "Color","green","LineWidth",0.5);
zoom(ax4,2);
```

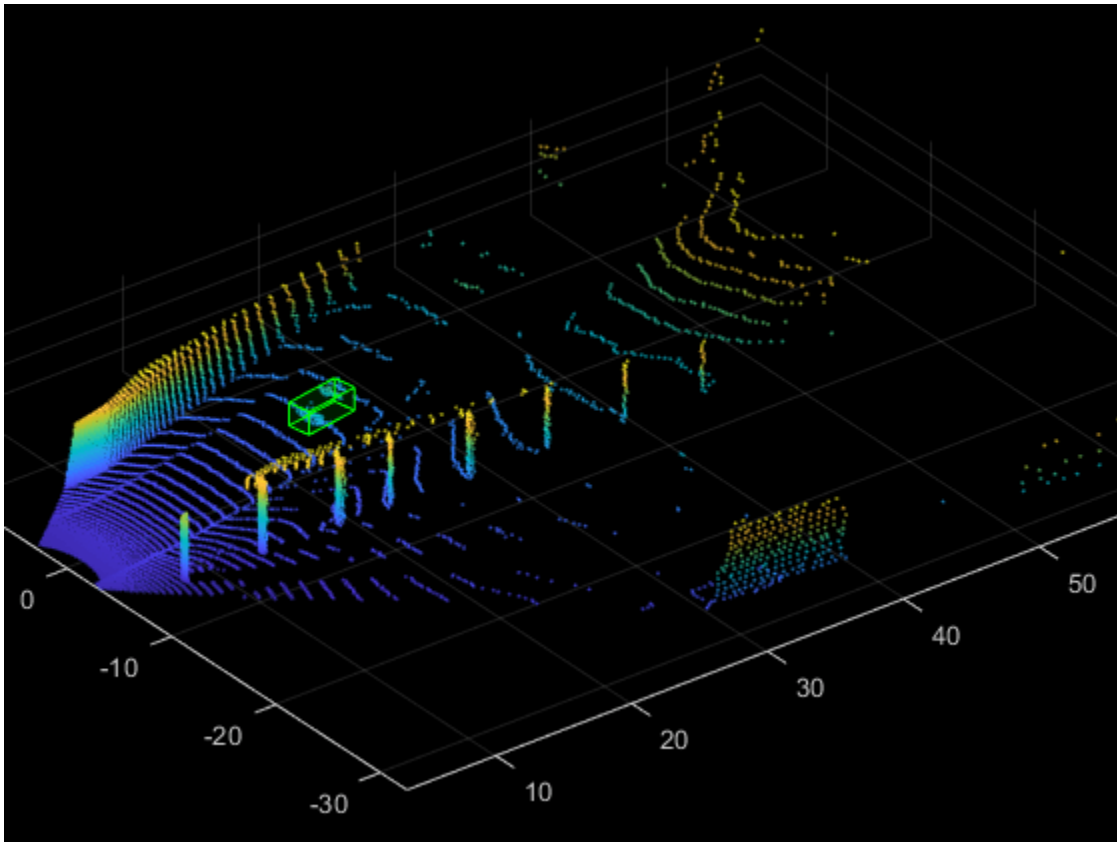

### Ground Truth Data Augmentation

Ground truth data augmentation is a technique which introduces randomly selected ground truth boxes from a data store or another point cloud into the current point cloud while training [1 on page 1-0 ]. Using this approach, you can increase the number of ground truth boxes per point cloud and simulate objects in different environments. To avoid physically impossible outcomes, you perform a collision test on the samples to be added and the ground truth boxes of the current point cloud. Use this augmentation technique when there is a class imbalance in the data set.

Use the `sampleLidarData` function to sample 3-D bounding boxes and the corresponding points from a datastore. You can filter out the sampled points using `minPoints` and store the filtered samples at a location specified by the `sampleLocation`.

```
classNames = {'car'};
minPoints = 20;
sampleLocation = fullfile(tempdir,"GTSamples");
[ldsSampled,bdsSampled] = sampleLidarData(cds,classNames,"MinPoints",minPoints,...
    "WriteLocation",sampleLocation,"Verbose",false);
cdsSampled = combine(ldsSampled,bdsSampled);
```

Use the `pcBboxOversample` function to randomly augment a fixed number of objects to the point cloud from the class "car". Define the total number of objects in the output point cloud using `totalObjects`.

```
totalObjects = 5;
cdsAugmented = transform(cds,@(x)pcBboxOversample(x,cdsSampled,classNames,totalObjects));
```

Display the point cloud along with the ground truth augmented boxes.

```
augData = read(cdsAugmented);
augptCld = augData{1,1};
augLabels = augData{1,2};
figure;
ax5 = pcshow(augptCld.Location);
showShape("cuboid",augLabels,"Parent",ax5,"Opacity",0.1, ...
          "Color","green","LineWidth",0.5);
zoom(ax5,2);
```

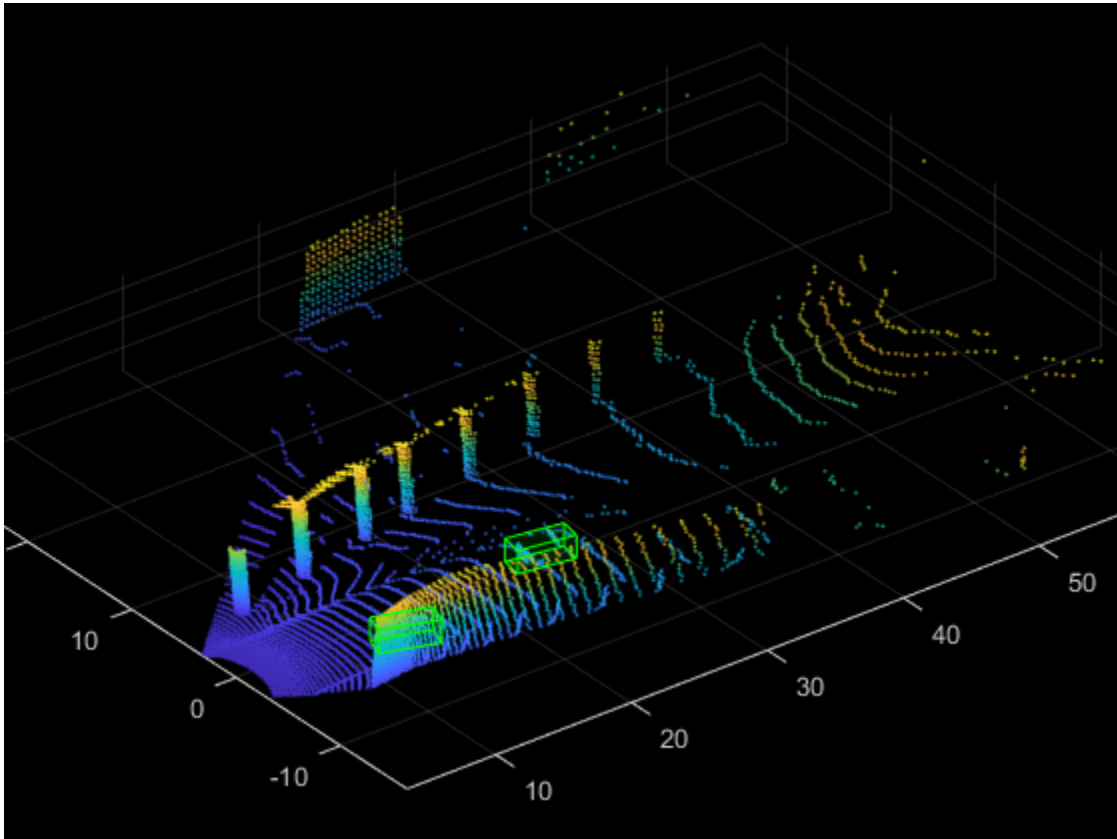

### Local Data Augmentation

Local data augmentation applies augmentation only to the points inside the ground truth boxes in a point cloud [1 on page 1-0 ]. The rest of the point cloud remains the same.

Read the point cloud and corresponding ground truth label.

```
reset(cds);
inputData = read(cds);
ptCloud = inputData{1,1};
gtLabels = inputData{1,2};
gtLabelsTransformed = zeros(size(gtLabels));
for i = 1:size(gtLabels,1)
    labelParams = gtLabels(i,:);
    centroidLoc = labelParams(1,1:3);
    model = cuboidModel(labelParams);
```



```

indices = findPointsInsideCuboid(model,ptCloud);
numPointsInside = size(indices,1);

```

Segregate the ground truth points from the original point cloud using the helper function `removeIndicesFromPointCloud`, attached to this example as a supporting file.

```

updatedPtCloud = removeIndicesFromPtCloud(ptCloud,indices);
cubPtCloud = select(ptCloud,indices);

% Shift the segregated point cloud to the origin.
numPoints = cubPtCloud.Count;
shiftRange = -1.*repmat(centroidLoc,[numPoints 1]);
cubPtCloud = pctransform(cubPtCloud,shiftRange);

% Define the minimum and maximum yaw angles for rotation.
minYawAngle = -45;
maxYawAngle = 45;

% Calculate a random angle from the specified yaw angle range.
theta = minYawAngle + rand*(maxYawAngle - minYawAngle);

% Create a transformation that rotates, translates, and scales the
% point clouds and 3-D bounding boxes.
tform = randomAffine3d("Rotation",@() deal([0 0 1],theta),...
    "Scale",[0.95 1.05],...
    "XTranslation",[0 0.2],...
    "YTranslation",[0 0.2],...
    "ZTranslation",[0 0.1]);

% Apply transformation to the 3-D bounding box.
labelParams(1,1:3) = labelParams(1,1:3) - centroidLoc;
labelParamsTransformed = bboxwarp(labelParams,tform,outView);

% Calculate the overlap ratio between the transformed box and the
% original ground truth boxes by converting them to rotated rectangle
% format, defined as [xcenter,ycenter,width,height,yaw].
overlapRatio = bboxOverlapRatio(labelParamsTransformed(:,[1,2,4,5,9]), ...
    gtLabels(:,[1,2,4,5,9]));
[maxOverlapRatio, maxOverlapIdx] = max(overlapRatio);

% Check if any transformed boxes overlap with the ground truth
% boxes.
if (maxOverlapRatio > 0) && (maxOverlapIdx ~= i)
    shiftRange = -1.*shiftRange;
    cubPtCloud = pctransform(cubPtCloud,shiftRange);
    updatedPtCloud = pccat([updatedPtCloud,cubPtCloud]);
    gtLabelsTransformed(i,1) = labelParams;
else
    cubPtCloudTransformed = pctransform(cubPtCloud,tform);
    shiftRange = -1.*shiftRange;
    cubPtCloudTransformed = pctransform(cubPtCloudTransformed,shiftRange);
    updatedPtCloud = pccat([updatedPtCloud,cubPtCloudTransformed]);
    gtLabelsTransformed(i,:) = labelParamsTransformed;
end
gtLabelsTransformed(i,1:3) = gtLabelsTransformed(i,1:3) + centroidLoc;
ptCloud = updatedPtCloud;
end

```

Display the point cloud along with the augmented ground truth boxes.

```
figure;  
ax6 = pcshow(updatedPtCloud.Location);  
showShape("cuboid",gtLabelsTransformed,"Parent",ax6,"Opacity",0.1, ...  
          "Color","green","LineWidth",0.5);  
zoom(ax6,2);
```

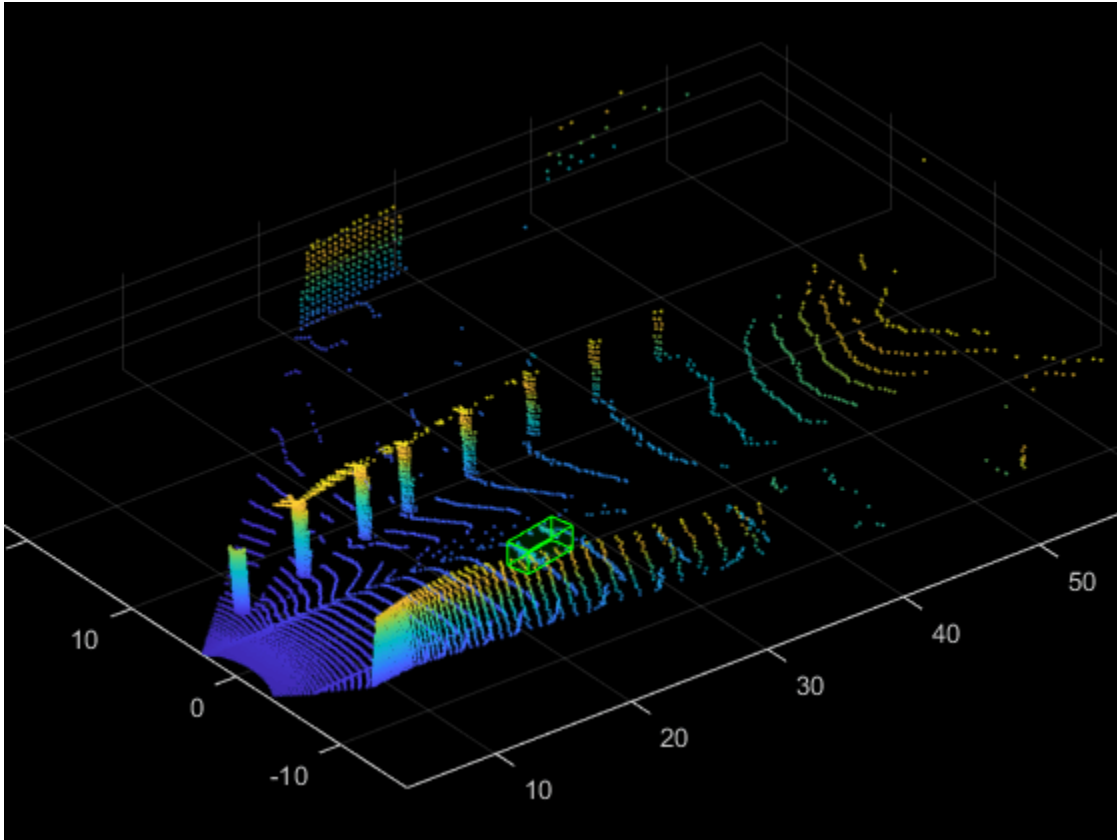

```
reset(cds);
```

## References

- [1] Hahner, Martin, Dengxin Dai, Alexander Liniger, and Luc Van Gool. "Quantifying Data Augmentation for LiDAR Based 3D Object Detection." Preprint, submitted April 3, 2020. <https://arxiv.org/abs/2004.01643>.

# Unorganized to Organized Conversion of Point Clouds Using Spherical Projection

This example shows how to convert unorganized point clouds to organized format using spherical projection.

## Introduction

A 3-D lidar point cloud is usually represented as a set of Cartesian coordinates  $(x, y, z)$ . A point cloud also contains additional information such as intensity, and RGB values. Unlike the distribution of image pixels, the distribution of a lidar point cloud is usually sparse and irregular. Processing such sparse data is inefficient. To obtain a compact representation, you project lidar point clouds onto a sphere to create a dense, grid-based representation known as an organized representation [1 on page 1-0 ]. To learn more about the differences between organized and unorganized point clouds, see “What are Organized and Unorganized Point Clouds?”. Ground plane extraction and key point detector methods require organized point clouds. Additionally, you must convert your point cloud to organized format if you want to use most deep learning segmentation networks, including SqueezeSegV1, SqueezeSegV2, RangeNet++ [2 on page 1-0 ], and SalsaNext [3 on page 1-0 ]. For an example showing how to use deep learning with an organized point cloud see “Lidar Point Cloud Semantic Segmentation Using SqueezeSegV2 Deep Learning Network” on page 1-173 example.

## Lidar Sensor Parameters

To convert an unorganized point cloud to organized format using spherical projection, you must specify the parameters of the lidar sensor used to create the point cloud. Refer to the data sheet of your sensor to know more about the sensor parameters. You can specify the following parameters.

- Beam configuration — 'uniform' or 'gradient'. Specify 'uniform' if the beams have equal spacing. Specify 'gradient' if the beams at the horizon are tightly packed, and those toward the top and bottom of the sensor field of view are more spaced out.
- Vertical resolution — Number of channels in the vertical direction, that is, the number of lasers. Typical values are 32, and 64.
- Vertical beam angles — Angular position of each vertical channel. You must specify this parameter when beam configuration is 'gradient'.
- Upward vertical field of view — Field of view in the vertical direction above the horizon (in degrees).
- Downward vertical field of view — Field of view in the vertical direction below the horizon (in degrees).
- Horizontal resolution — Number of channels in horizontal direction. Typical values are 512, and 1024.
- Horizontal angular resolution — The angular resolution between each channel along horizontal direction. You must specify this parameter when horizontal resolution is not mentioned in the datasheet.
- Horizontal field of view — Field of view covered in the horizontal direction (in degrees). In most cases, this value is 360 degrees.

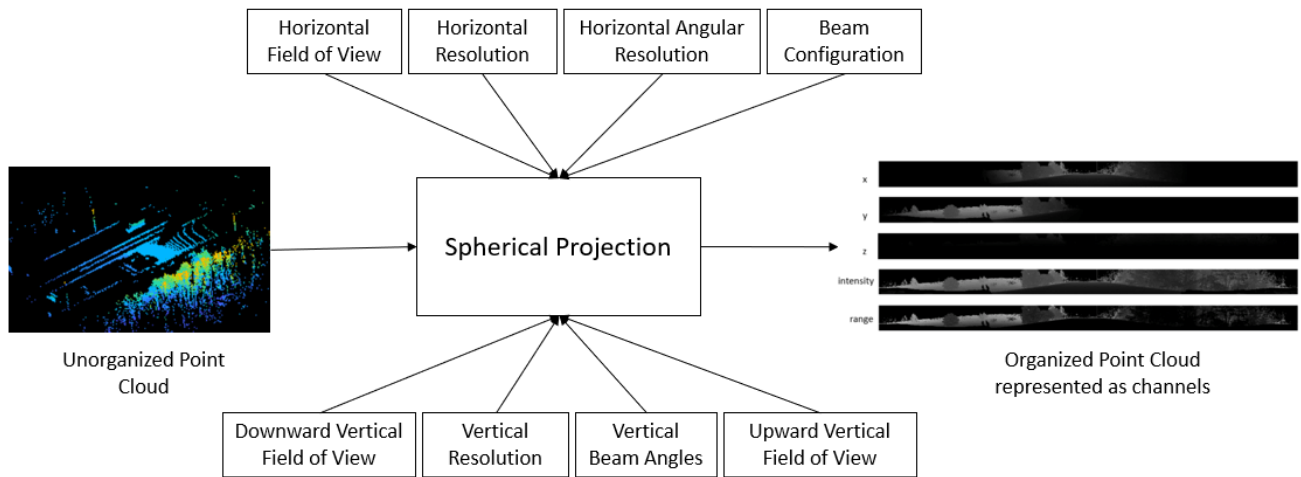

You can specify most of the above sensor parameters using a `lidarParameters` object

### Ouster OS-1 Sensor

Read the point cloud using the `pcread` function.

```
fileName = fullfile(matlabroot, 'examples', 'deeplearning_shared', 'data', 'ousterLidarDrivingData.p
ptCloud = pcread(fileName);
```

Check the size of the sample point cloud. If the point cloud coordinates are in the form,  $M$ -by- $N$ -by-3, it is an organized point cloud.

```
isOrganized = size(ptCloud.Location,3) == 3;
```

Remove the invalid points and convert the point cloud to unorganized format using `removeInvalidPoints` function.

```
if isOrganized
    ptCloudUnOrg = removeInvalidPoints(ptCloud);
end
```

The point cloud data was collected from an Ouster OS1 Gen1 sensor. Specify the sensor parameters using `lidarParameters` function.

```
hResolution = 1024;
params = lidarParameters("OS1Gen1-64",hResolution);
```

Convert the unorganized point cloud to organized format using the `pcorganize` function.

```
ptCloudOrg = pcorganize(ptCloudUnOrg,params);
```

Display the intensity channel of the original and reconstructed organized point clouds.

```
figure
montage({uint8(ptCloud.Intensity),uint8(ptCloudOrg.Intensity)});
title("Intensity Channel of Original Point Cloud(Top) vs. Reconstructed Organized Point Cloud(Bottom)");
```

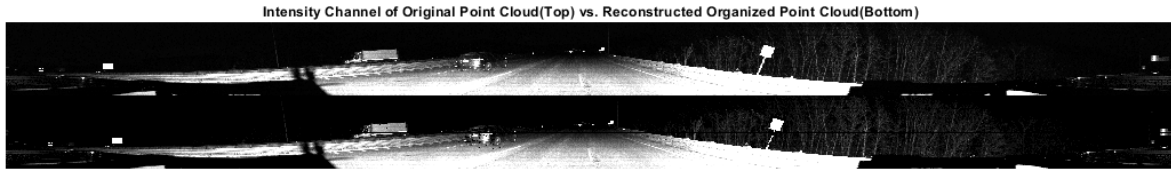

Display both the original organized point cloud and the reconstructed organized point cloud using the `helperShowUnorgAndOrgPair` helper function, attached to this example as a supporting file.

```
display1 = helperShowUnorgAndOrgPair();
zoomFactor = 3.5;
display1.plotLidarScan(ptCloud,ptCloudOrg,zoomFactor);
```

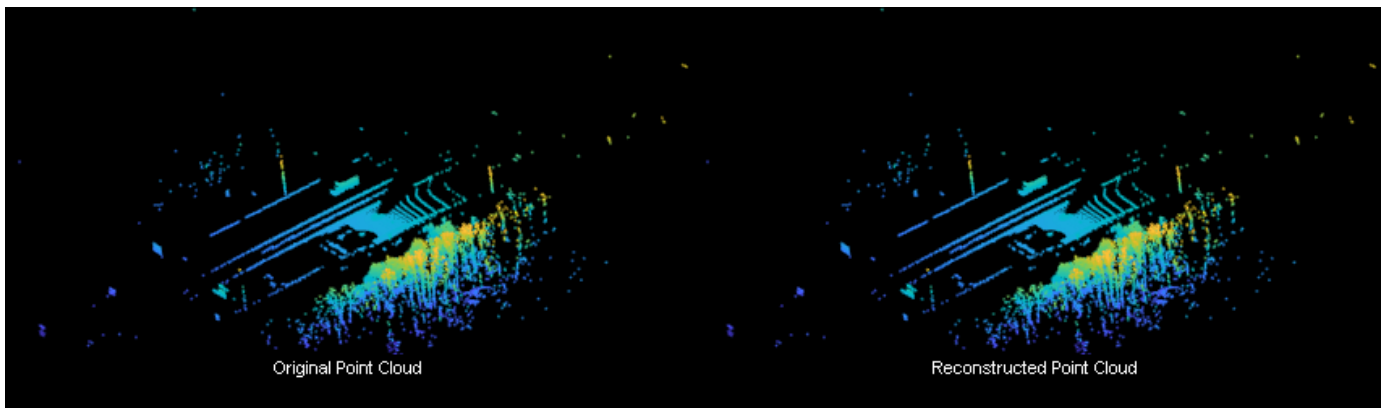

## Velodyne Sensor

Read the point cloud using the `pcread` function.

```
ptCloudUnOrg = pcread('HDL64LidarData.pcd');
```

The point cloud data is collected from the Velodyne HDL-64 sensor. Specify the sensor parameters using `lidarParameters` function.

```
hResolution = 1024;
params = lidarParameters("HDL64E",hResolution);
```

Convert the unorganized point cloud to organized format using the `pcorganize` function.

```
ptCloudOrg = pcorganize(ptCloudUnOrg,params);
```

Display the intensity channel of the reconstructed organized point cloud. Resize the image for better visualization.

```
intensityChannel = ptCloudOrg.Intensity;
intensityChannel = imresize(intensityChannel,'Scale',[3 1]);
figure
imshow(intensityChannel);
```

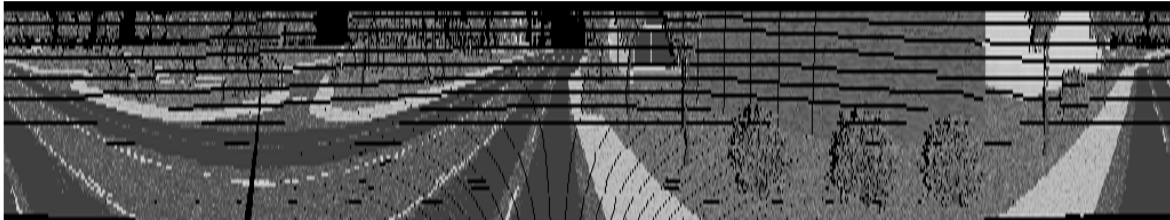

Display both the original organized point cloud and the reconstructed organized point cloud using the `helperShowUnorgAndOrgPair` helper function, attached to this example as a supporting file.

```
display2 = helperShowUnorgAndOrgPair();  
zoomFactor = 2.5;  
display2.plotLidarScan(ptCloudUnOrg,ptCloudOrg,zoomFactor);
```

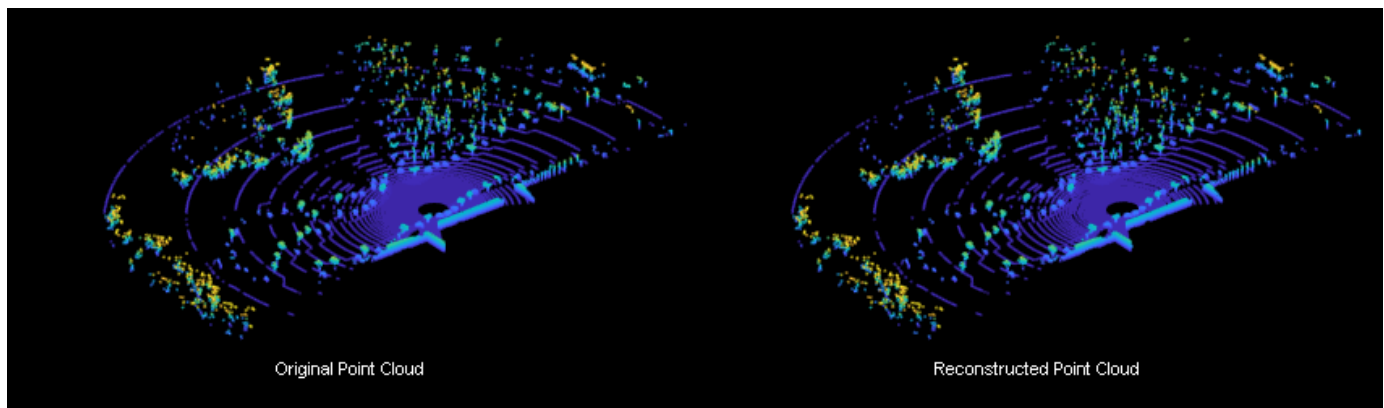

## Configure the Sensor Parameters

For any given point cloud, you can specify the sensor parameters like vertical and horizontal resolution, vertical and horizontal field-of-view when converting to organized format.

Read the point cloud using the `pcread` function.

```
ptCloudUnOrg = pcread('HDL64LidarData.pcd');
```

The point cloud data is collected from the Velodyne HDL-64 sensor. You can configure the sensor by specifying different parameters.

```
% Define vertical and horizontal resolution.  
vResolution = 32;  
hResolution = 512;
```

```
% Define vertical and horizontal field-of-view.  
vFoVUp = 2;  
vFoVDown = -24.9;  
vFoV = [vFoVUp vFoVDown];  
hFoV = 270;
```

Specify the sensor parameters using `lidarParameters` function.

```
params = lidarParameters(vResolution,vFoV,hResolution,"HorizontalFoV",hFoV);
```

Convert the unorganized point cloud to organized format using the `pcorganize` function.

```
ptCloudOrg = pcorganize(ptCloudUnOrg,params);
```

Display the intensity channel of the reconstructed organized point cloud. Resize the image for better visualization.

```
intensityChannel = ptCloudOrg.Intensity;
intensityChannel = imresize(intensityChannel,'Scale',[3 1]);
figure
imshow(intensityChannel);
```

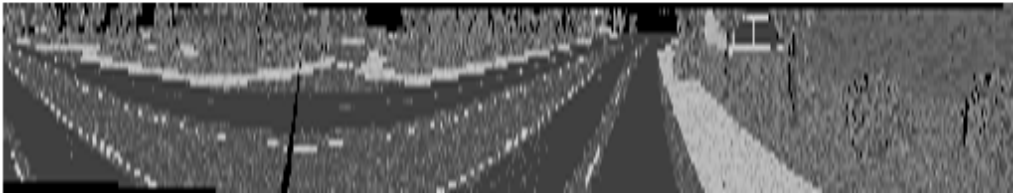

Display both the original organized point cloud and the reconstructed organized point cloud using the `helperShowUnorgAndOrgPair` helper function, attached to this example as a supporting file.

```
display3 = helperShowUnorgAndOrgPair();
display3.plotLidarScan(ptCloudUnOrg,ptCloudOrg,zoomFactor);
```

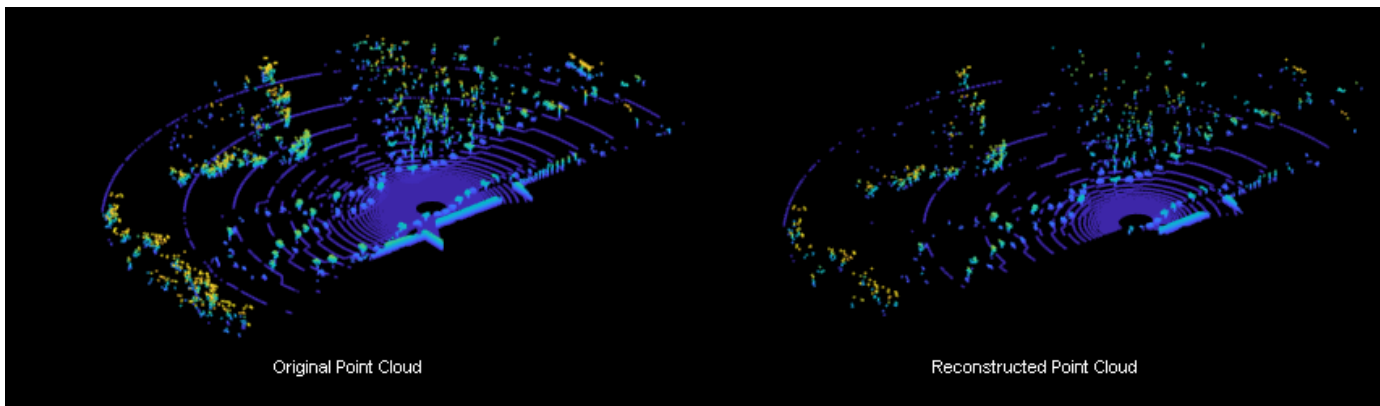

### Pandar Sensor

Read the point cloud using the `pcread` function.

```
ptCloudUnOrg = pcread('Pandar64LidarData.pcd');
```

The point cloud data is collected using a Pandar-64 sensor [4 on page 1-0 ]. You can specify the following parameters, using the information given in the device datasheet [5 on page 1-0 ].

```
vResolution = 64;  
hAngResolution = 0.2;
```

The beam configuration is 'gradient', meaning that the beam spacing is not uniform. Specify the beam angle values along the vertical direction.

```
vbeamAngles = [15.0000  11.0000   8.0000   5.0000   3.0000   2.0000   1.8333   1.6667  
               0.5000   0.3333   0.1667   0          -0.1667  -0.3333  -0.5000  -0.6667  
              -1.8333  -2.0000  -2.1667  -2.3333  -2.5000  -2.6667  -2.8333  -3.0000  
              -4.1667  -4.3333  -4.5000  -4.6667  -4.8333  -5.0000  -5.1667  -5.3333  
              -9.0000 -10.0000 -11.0000 -12.0000 -13.0000 -14.0000 -19.0000 -25.0000];
```

Calculate the horizontal resolution.

```
hResolution = round(360/hAngResolution);
```

Define the sensor parameters using `lidarParameters` function.

```
params = lidarParameters(vbeamAngles,hResolution);
```

Convert the unorganized point cloud to organized format using the `pcorganize` function.

```
ptCloudOrg = pcorganize(ptCloudUnOrg,params);
```

Display the intensity channel of the reconstructed organized point cloud. Resize the image and use `histeq` for better visualization.

```
intensityChannel = ptCloudOrg.Intensity;  
intensityChannel = imresize(intensityChannel,'Scale',[3 1]);  
figure  
histeq(intensityChannel./max(intensityChannel(:)));
```



Display both the original organized point cloud and the reconstructed organized point cloud using the `helperShowUnorgAndOrgPair` helper function, attached to this example as a supporting file.

```
display4 = helperShowUnorgAndOrgPair();  
zoomFactor = 4;  
display4.plotLidarScan(ptCloudUnOrg,ptCloudOrg,zoomFactor);
```



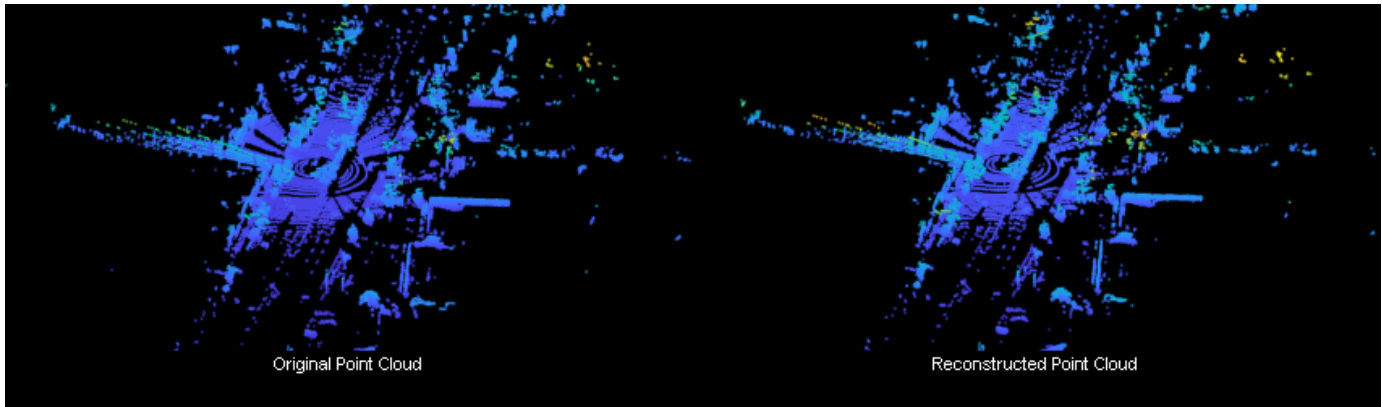

## References

- [1] Wu, Bichen, Alvin Wan, Xiangyu Yue, and Kurt Keutzer. "SqueezeSeg: Convolutional Neural Nets with Recurrent CRF for Real-Time Road-Object Segmentation from 3D LiDAR Point Cloud." In 2018 *IEEE International Conference on Robotics and Automation (ICRA)*, 1887-93. Brisbane, QLD: IEEE, 2018. <https://doi.org/10.1109/ICRA.2018.8462926>.
- [2] Milioto, Andres, Ignacio Vizzo, Jens Behley, and Cyrill Stachniss. "RangeNet ++: Fast and Accurate LiDAR Semantic Segmentation." In 2019 *IEEE/RSJ International Conference on Intelligent Robots and Systems (IROS)*, 4213-20. Macau, China: IEEE, 2019. <https://doi.org/10.1109/IROS40897.2019.8967762>.
- [3] Cortinhal, Tiago, George Tzelepis, and Eren Erdal Aksoy. "SalsaNext: Fast, Uncertainty-Aware Semantic Segmentation of LiDAR Point Clouds for Autonomous Driving." *ArXiv:2003.03653 [Cs]*, July 9, 2020. <http://arxiv.org/abs/2003.03653>.
- [4] "PandaSet Open Datasets - Scale." Accessed December 22, 2020. <https://scale.com/open-datasets/pandaset>.
- [5] "Pandar64 User Manual." Accessed December 22, 2020. [https://hesaiweb2019.blob.core.chinacloudapi.cn/uploads/Pandar64\\_User's\\_Manual.pdf](https://hesaiweb2019.blob.core.chinacloudapi.cn/uploads/Pandar64_User's_Manual.pdf).

## Lane Detection in 3-D Lidar Point Cloud

This example shows how to detect lanes in lidar point clouds. You can use the intensity values returned from lidar point clouds to detect ego vehicle lanes. You can further improve the lane detection by using a curve-fitting algorithm and tracking the curve parameters. Lidar lane detection enables you to build complex workflows like lane keep assist, lane departure warning, and adaptive cruise control for autonomous driving. A test vehicle collects the lidar data using a lidar sensor mounted on its rooftop.

### Introduction

Lane detection in lidar involves detection of the immediate left and right lanes, also known as ego vehicle lanes, with respect to the lidar sensor. It involves the following steps:

- Region of interest extraction
- Ground plane segmentation
- Peak intensity detection
- Lane detection using window search
- Parabolic polynomial fitting
- Parallel lane fitting
- Lane tracking

This flowchart gives an overview of the workflow presented in this example.

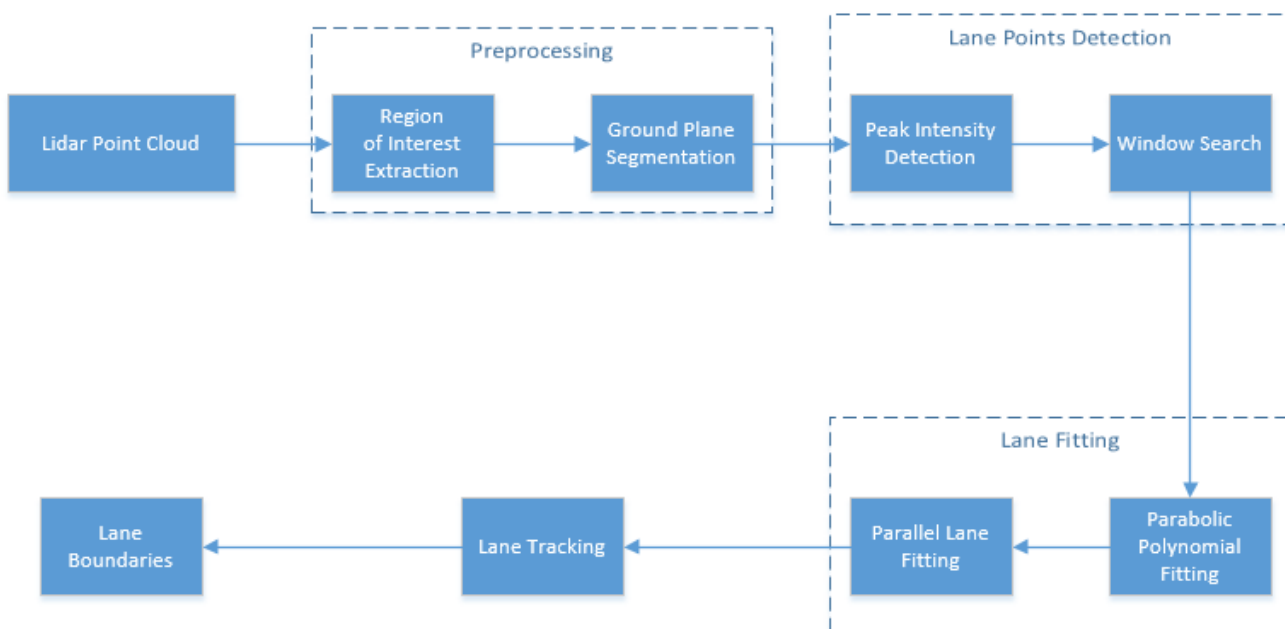

The advantages of using lidar data for lane detection are :

- Lidar point clouds give a better 3-D representation of the road surface than image data, thus reducing the required calibration parameters to find the bird's-eye view.

- Lidar is more robust against adverse climatic conditions than image-based detection.
- Lidar data has a centimeter level of accuracy, leading to accurate lane localization.

### Download and Prepare Lidar Data Set

The lidar data used in this example has been collected using the Ouster OS1-64 channel lidar sensor, producing high-resolution point clouds. This data set contains point clouds stored as a cell array of `pointCloud` object. Each 3-D point cloud consists of XYZ locations along with intensity information.

**Note:** Download time of the data depends on your internet connection. MATLAB will be temporarily unresponsive during the execution of this code block.

```
% Download lidar data  
lidarData = helperGetDataset;
```

Selecting the first frame of the dataset for further processing.

```
% Select first frame  
ptCloud = lidarData{1};  
  
% Visualize input point cloud  
figure  
pcshow(ptCloud)  
title('Input Lidar Point Cloud')  
axis([0 50 -15 15 -5 5])  
view([-42 35])
```

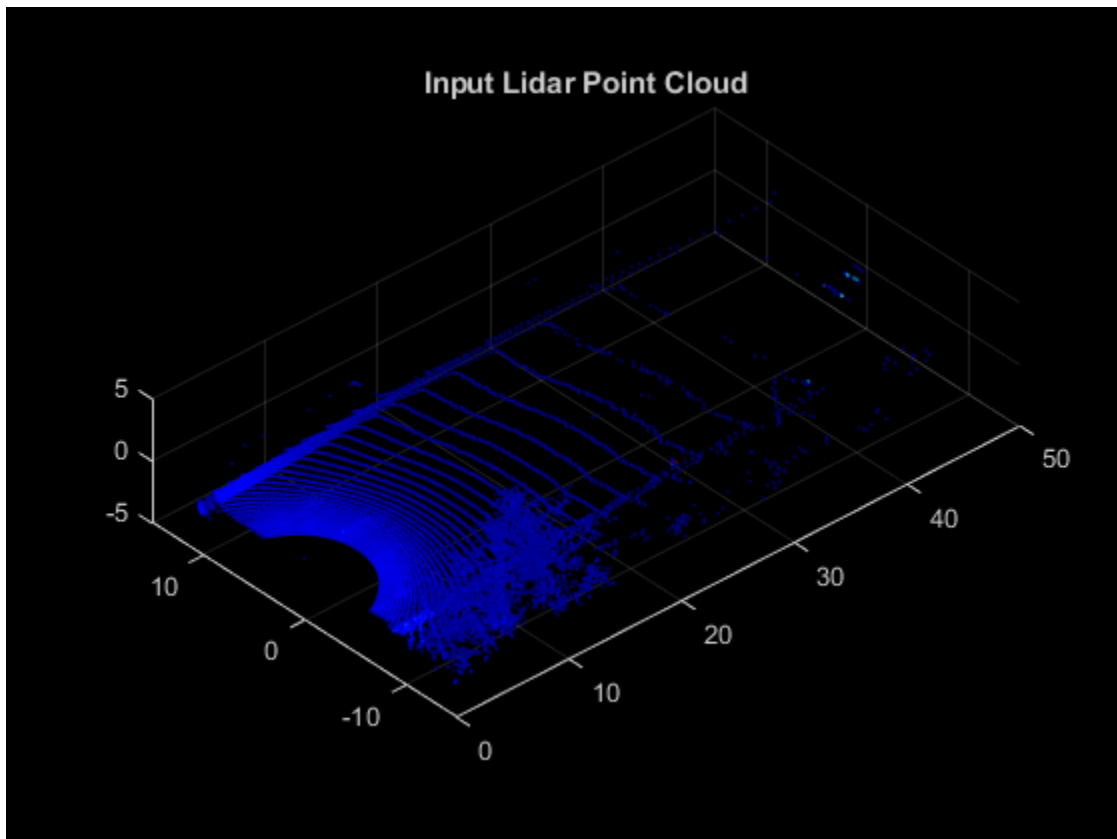

## Preprocessing

To estimate the lane points, first preprocess the lidar point clouds. Preprocessing involves the following steps:

- Region of interest extraction
- Ground plane segmentation

```
% Define ROI in meters
xlim = [5 55];
ylim = [-3 3];
zlim = [-4 1];
roi = [xlim ylim zlim];

% Crop point cloud using ROI
indices = findPointsInROI(ptCloud,roi);
croppedPtCloud = select(ptCloud,indices);

% Remove ground plane
maxDistance = 0.1;
referenceVector = [0 0 1];
[model,inliers,outliers] = pcfitplane(croppedPtCloud,maxDistance,referenceVector);
groundPts = select(croppedPtCloud,inliers);

figure
pcshow(groundPts)
title('Ground Plane')
view(3)
```

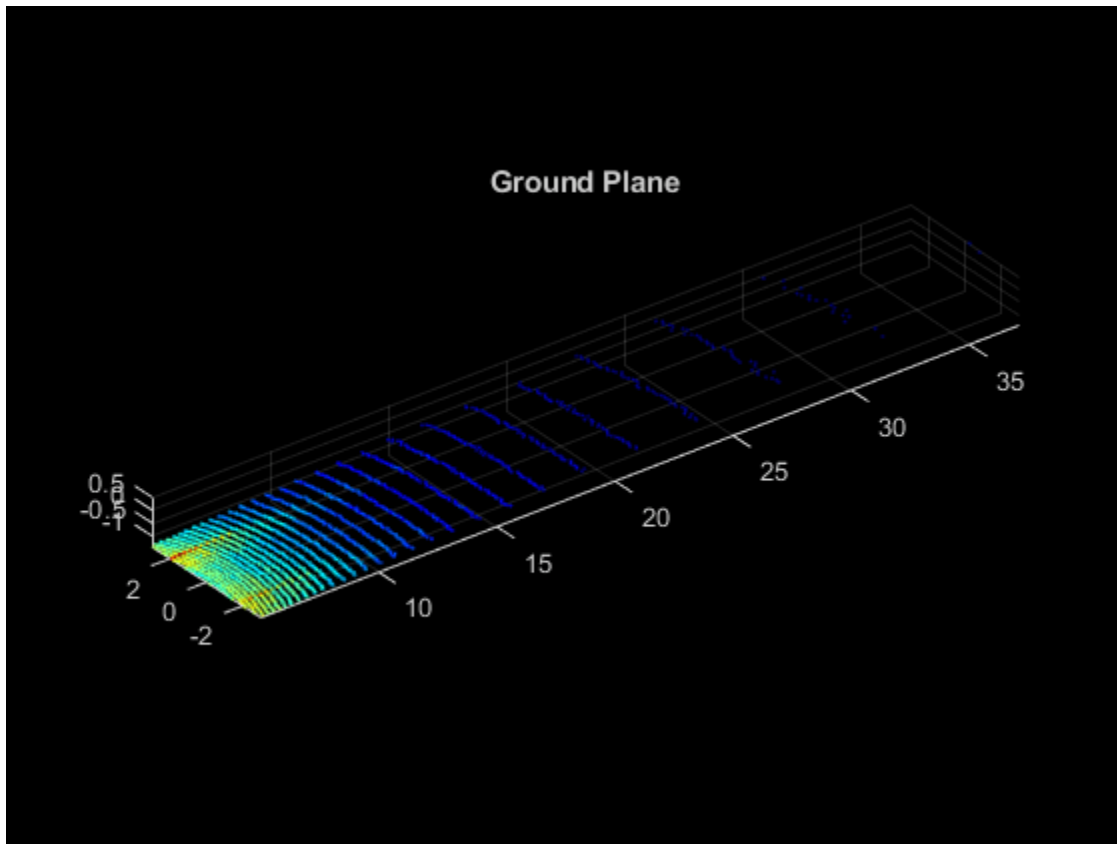

### Lane Point Detection

Detect lane points by using a sliding window search, where the initial estimates for the sliding windows are made using an intensity-based histogram.

Lane point detection consists primarily of these two steps:

- Peak intensity detection
- Window search

### Peak Intensity Detection

Lane points in the lidar point cloud have a distinct distribution of intensities. Usually, these intensities occupy the upper region in the histogram distribution and appear as high peaks. Compute a histogram of intensities from the detected ground plane along the ego vehicle axis (positive X-axis). The `helperComputeHistogram` helper function creates a histogram of intensity points. Control the number of bins for the histogram by specifying the bin resolution.

```
histBinResolution = 0.2;
[histVal,yvals] = helperComputeHistogram(groundPts,histBinResolution);

figure
plot(yvals,histVal,'--k')
set(gca,'XDir','reverse')
hold on
```

Obtain peaks in the histogram by using the `helperfindpeaks` helper function. Further filter the possible lane points based on lane width using the `helperInitialWindow` helper function.

```
[peaks,locs] = helperfindpeaks(histVal);
startYs = yvals(locs);

laneWidth = 4;
[startLanePoints,detectedPeaks] = helperInitialWindow(startYs,peaks,laneWidth);

plot(startYs,peaks,'*r')
plot(startLanePoints,detectedPeaks,'og')
legend('Histogram','Peak','Detected Peaks','Location','North')
title('Peak Detection')
hold off
```

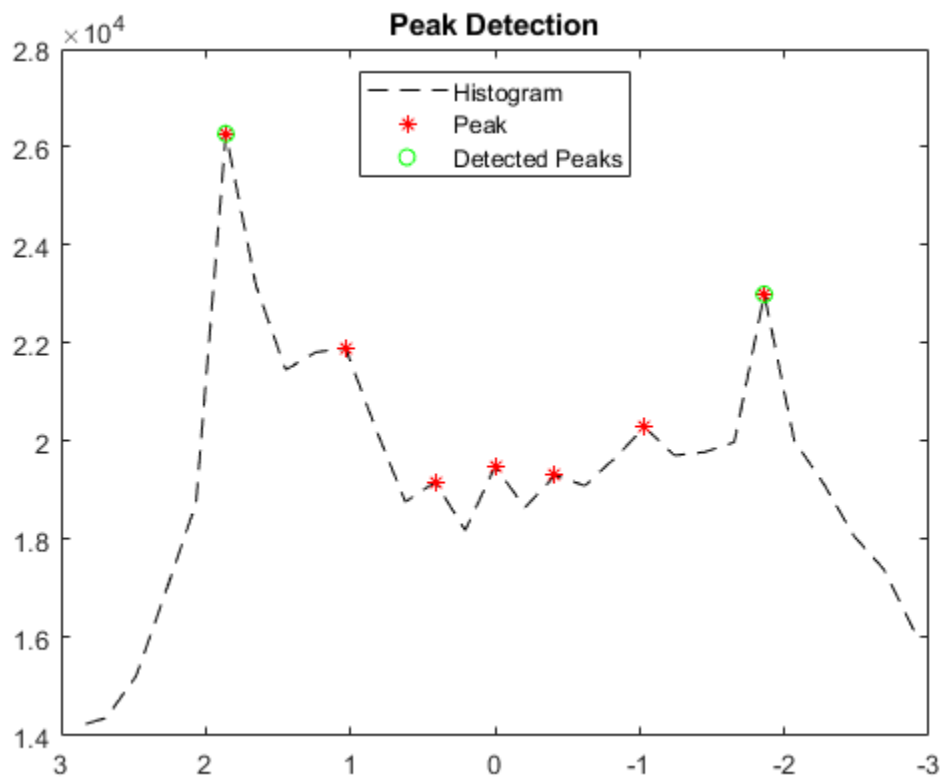

### Window Search

Window search is used to detect lane points by sliding the windows along the lane curvature direction. Window search consists of two steps:

- Window initialization
- Sliding window

### Window Initialization

The detected peaks help in the initialization of the search window. Initialize the search windows as multiple bins with red and blue colors for left and right lanes respectively.

```

vBinRes = 1;
hBinRes = 0.8;
numVerticalBins = ceil((groundPts.XLimits(2) - groundPts.XLimits(1))/vBinRes);
laneStartX = linspace(groundPts.XLimits(1),groundPts.XLimits(2),numVerticalBins);

% Display bin windows
figure
pcshow(groundPts)
view(2)
helperDisplayBins(laneStartX,startLanePoints(1),hBinRes/2,groundPts,'red');
helperDisplayBins(laneStartX,startLanePoints(2),hBinRes/2,groundPts,'blue');
title('Initialized Sliding Windows')

```

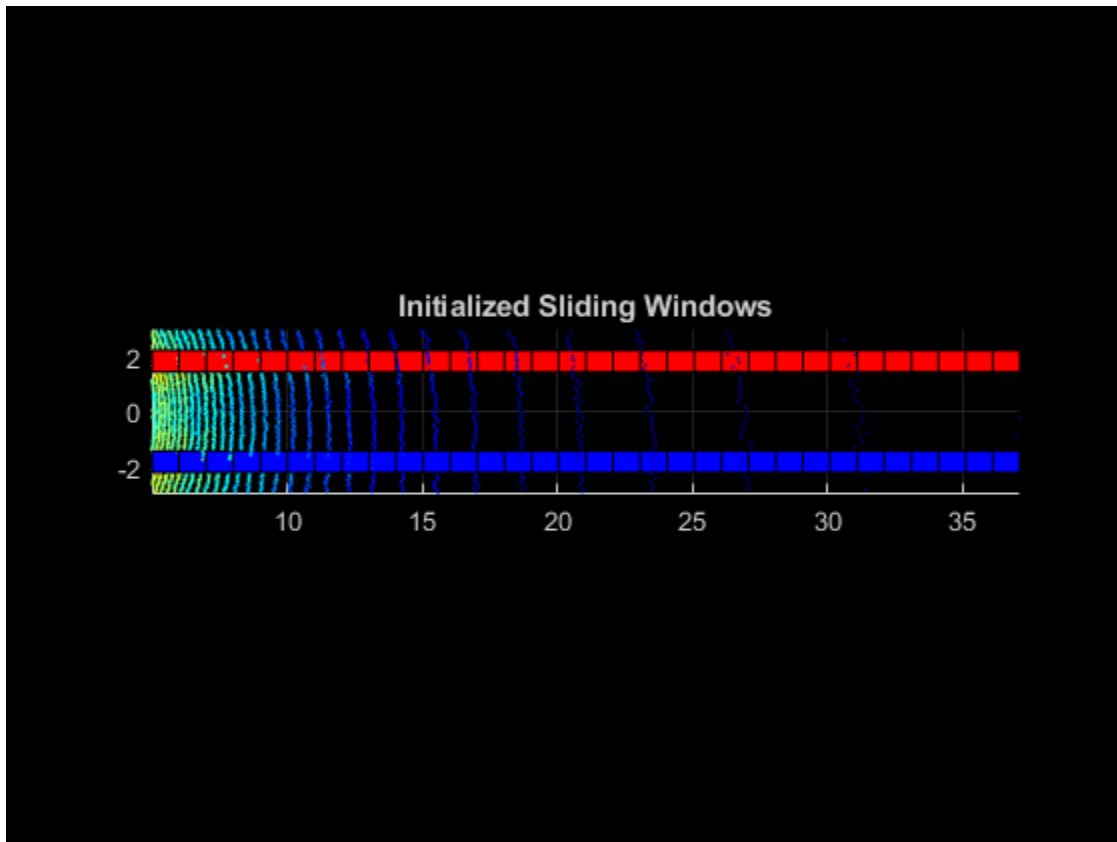

### Sliding Window

The sliding bins are initialized from the bin locations, and iteratively move along the ego vehicle (positive X-axis) direction. The `helperDetectLanes` helper function detects lane points and visualizes the sliding bins. Consecutive bins slide along the Y-axis based upon the intensity values inside the previous bin.

At regions where the lane points are missing, the function predicts the sliding bins using second-degree polynomial. This condition commonly arises when there are moving object's crossing the lanes. The sliding bins are yellow and the bins that are predicted using the polynomial are green.

```

display = true;
lanes = helperDetectLanes(groundPts,hBinRes, ...
    numVerticalBins,startLanePoints,display);

```

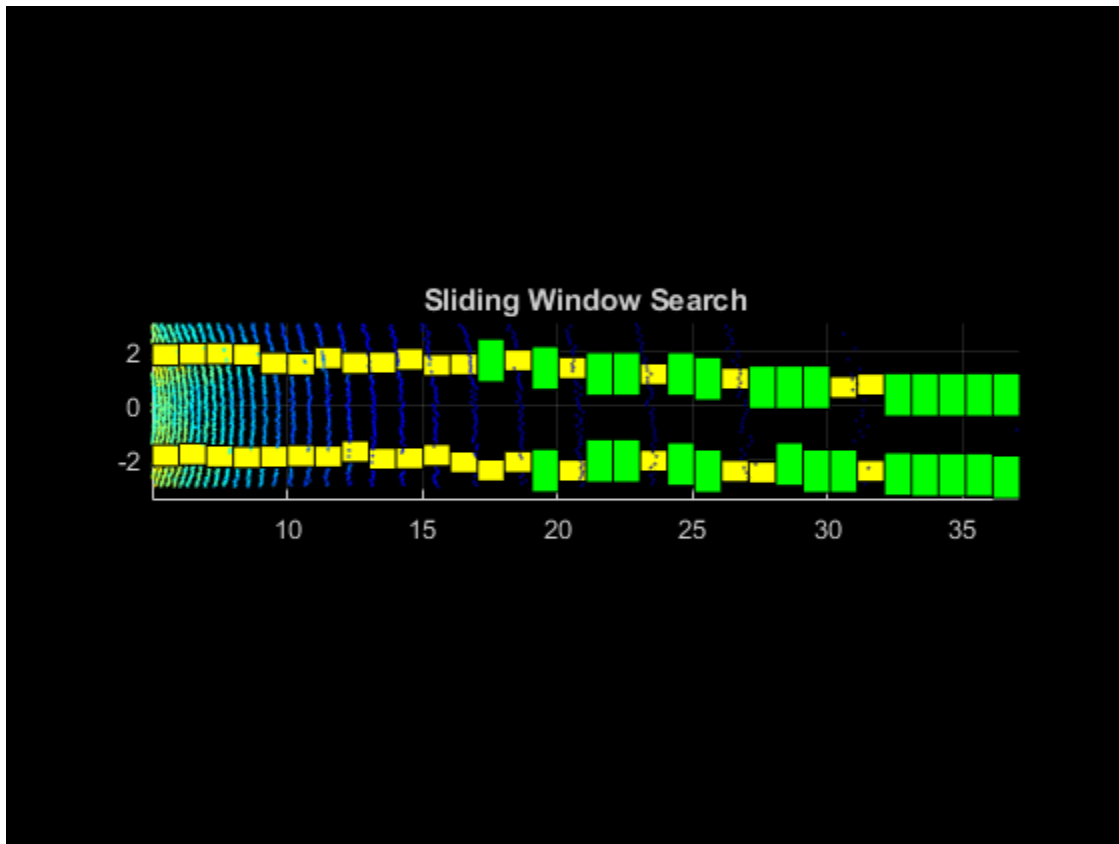

```

% Plot final lane points
lane1 = lanes{1};
lane2 = lanes{2};

figure
pcshow(groundPts)
title('Detected Lane Points')
hold on
p1 = plot3(lane1(:,1),lane1(:,2),lane1(:,3),'*y');
p2 = plot3(lane2(:,1),lane2(:,2),lane2(:,3),'*r');
hold off
view(2)
lgnd = legend([p1 p2],{'Left Lane Points','Right Lane Points'});
set(lgnd,'color','White','Location','southoutside')

```



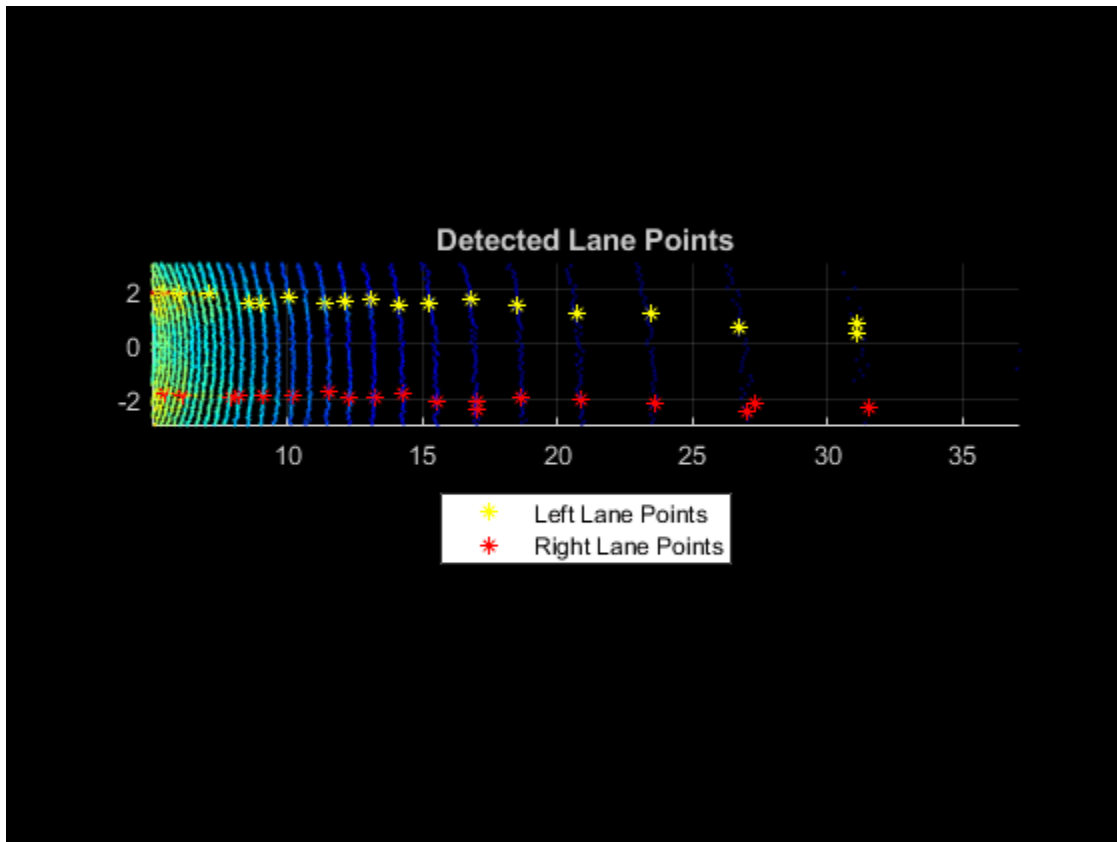

### Lane Fitting

Lane fitting involves estimating a polynomial curve on the detected lane points. These polynomials are used along with parallel lane constraint for lane fitting.

### Parabolic Polynomial Fitting

The polynomial is fitted on X-Y points using a 2-degree polynomial represented as  $ax^2 + bx + c$ , where  $a$ ,  $b$ , and  $c$  are polynomial parameters. To perform curve fitting, use the `helperFitPolynomial` helper function, which also handles outliers using the random sample consensus (RANSAC) algorithm. To estimate the 3-D lane points, extract the parameters from the plane model created during the preprocessing step. The plane model is represented as  $ax + by + cz + d = 0$ , where the Z-coordinate is unknown. Estimate the Z-coordinate by substituting the X- and Y-coordinates in the plane equation.

```
[P1,error1] = helperFitPolynomial(lane1(:,1:2),2,0.1);
[P2,error2] = helperFitPolynomial(lane2(:,1:2),2,0.1);

xval = linspace(5,40,80);
yval1 = polyval(P1,xval);
yval2 = polyval(P2,xval);

% Z-coordinate estimation
modelParams = model.Parameters;
zWorld1 = (-modelParams(1)*xval - modelParams(2)*yval1 - modelParams(4))/modelParams(3);
zWorld2 = (-modelParams(1)*xval - modelParams(2)*yval2 - modelParams(4))/modelParams(3);
```

```

% Visualize fitted lane
figure
pcshow(croppedPtCloud)
title('Fitted Lane Polynomial')
hold on
p1 = plot3(xval,yval1,zWorld1,'y','LineWidth',0.2);
p2 = plot3(xval,yval2,zWorld2,'r','LineWidth',0.2);
lgnd = legend([p1 p2],{'Left Lane Points','Right Lane Points'});
set(lgnd,'color','White','Location','southoutside')
view(2)
hold off

```

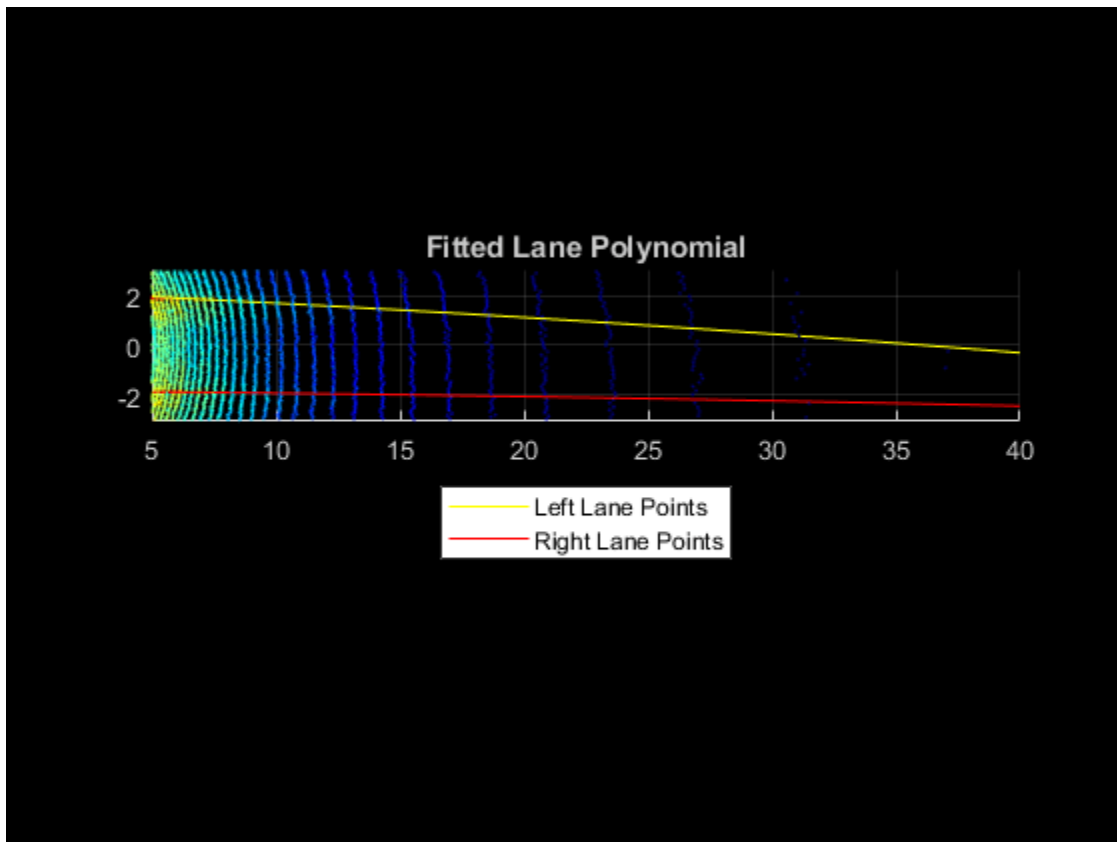

### Parallel Lane Fitting

The lanes are usually parallel to each other along the road. To make the lane fitting robust, use this parallel constraint. When fitting the polynomials, the `helperFitPolynomial` helper function also computes the fitting error. Update the lanes having erroneous points with the new polynomial. Update this polynomial by shifting it along the Y-axis.

```

lane3d1 = [xval' yval1' zWorld1'];
lane3d2 = [xval' yval2' zWorld2'];

% Shift the polynomial with a high score along the Y-axis towards
% the polynomial with a low score
if error1 > error2
    lanePolynomial = P2;
    if lane3d1(1,2) > 0

```

```

        lanePolynomial(3) = lane3d2(1,2) + laneWidth;
    else
        lanePolynomial(3) = lane3d2(1,2) - laneWidth;
    end
    lane3d1(:,2) = polyval(lanePolynomial, lane3d1(:,1));
    lanePolynomials = [lanePolynomial; P2];
else
    lanePolynomial = P1;
    if lane3d2(1,2) > 0
        lanePolynomial(3) = lane3d1(1,2) + laneWidth;
    else
        lanePolynomial(3) = lane3d1(1,2) - laneWidth;
    end
    lane3d2(:,2) = polyval(lanePolynomial, lane3d2(:,1));
    lanePolynomials = [P1; lanePolynomial]
end

% Visualize lanes after parallel fitting
figure
pcshow(ptCloud)
axis([0 50 -15 15 -5 5])
hold on
p1 = plot3(lane3d1(:,1), lane3d1(:,2), lane3d1(:,3), 'y', 'LineWidth', 0.2);
p2 = plot3(lane3d2(:,1), lane3d2(:,2), lane3d2(:,3), 'r', 'LineWidth', 0.2);
view([-90 90])
title('Fitted Lanes')
lgnd = legend([p1 p2], {'Left Lane Points', 'Right Lane Points'});
set(lgnd, 'color', 'White', 'Location', 'southoutside')
hold off

```

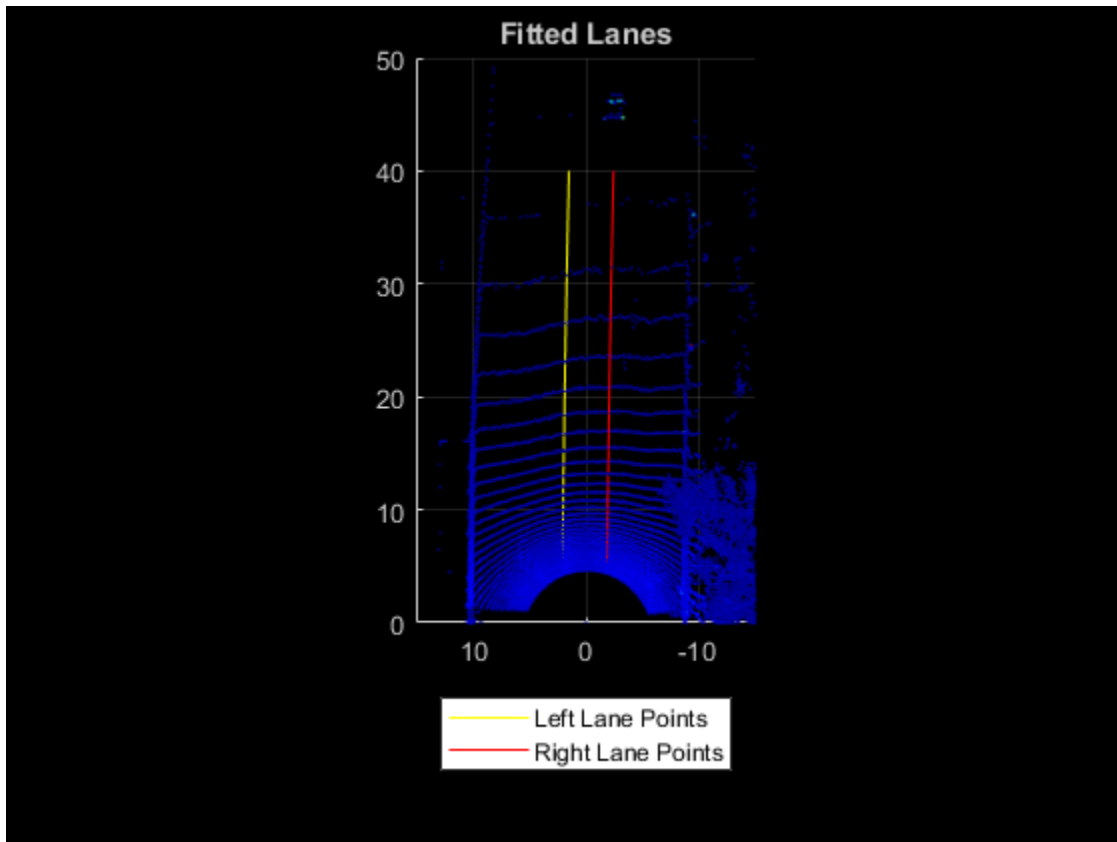

### Lane Tracking

Lane tracking helps in stabilizing the lane curvature caused by sudden jerks and drifts. These changes can occur because of missing lane points, vehicles moving over the lanes, and erroneous lane detection. Lane tracking is a two-step process:

- Track lane polynomial parameters( $a$ ,  $b$ ) to control the curvature of the polynomial.
- Track the start points coming from peak detection. This parameter is denoted as  $c$  in the polynomial.

These parameters are updated using a Kalman filter with a constant acceleration motion model. To initiate a Kalman filter, use the `configureKalmanFilter`.

```
% Initial values
curveInitialParameters = lanePolynomials(1,1:2);
driftInitialParameters = lanePolynomials(:,3)';
initialEstimateError = [1 1 1]*1e-1;
motionNoise = [1 1 1]*1e-7;
measurementNoise = 10;

% Configure Kalman filter
curveFilter = configureKalmanFilter('ConstantAcceleration', ...
    curveInitialParameters,initialEstimateError,motionNoise,measurementNoise);
driftFilter = configureKalmanFilter('ConstantAcceleration', ...
    driftInitialParameters,initialEstimateError,motionNoise,measurementNoise);
```

## Loop Through Data

Loop through and process the lidar data by using the `helperLaneDetector` helper class. This helper class implements all previous steps, and also performs additional preprocessing to remove the vehicles from the point cloud. This ensures that the detected ground points are flat and the plane model is accurate. The class method `detectLanes` detects and extracts the lane points for the left and right lane as a two-element cell array, where the first element corresponds to the left lane and the second element to the right lane.

```
% Initialize the random number generator
rng(2020)
numFrames = numel(lidarData);
detector = helperLaneDetector('ROI',[5 40 -3 3 -4 1]);

% Turn on display
player = pcplayer([0 50],[-15 15],[-5 5]);

drift = zeros(numFrames,1);
filteredDrift = zeros(numFrames,1);
curveSmoothness = zeros(numFrames,1);
filteredCurveSmoothness = zeros(numFrames,1);
for i = 1:numFrames
    ptCloud = lidarData{i};

    % Detect lanes
    detectLanes(detector,ptCloud);

    % Predict polynomial from Kalman filter
    predict(curveFilter);
    predict(driftFilter);

    % Correct polynomial using Kalman filter
    lanePolynomials = detector.LanePolynomial;
    drift(i) = mean(lanePolynomials(:,3));
    curveSmoothness(i) = mean(lanePolynomials(:,1));
    updatedCurveParams = correct(curveFilter, lanePolynomials(1,1:2));
    updatedDriftParams = correct(driftFilter, lanePolynomials(:,3)');

    % Update lane polynomials
    updatedLanePolynomials = [repmat(updatedCurveParams,[2 1]),updatedDriftParams'];

    % Estimate new lane points with updated polynomial
    lanes = updateLanePolynomial(detector,updatedLanePolynomials);
    filteredDrift(i) = mean(updatedLanePolynomials(:,3));
    filteredCurveSmoothness(i) = mean(updatedLanePolynomials(:,1));

    % Visualize lanes after parallel fitting
    ptCloud.Color = uint8(repmat([0 0 255],ptCloud.Count,1));
    lane3dPc1 = pointCloud(lanes{1});
    lane3dPc1.Color = uint8(repmat([255 0 0],lane3dPc1.Count,1));
    lanePc = pccat([ptCloud lane3dPc1]);
    lane3dPc2 = pointCloud(lanes{2});
    lane3dPc2.Color = uint8(repmat([255 255 0],lane3dPc2.Count,1));
    lanePc = pccat([lanePc lane3dPc2]);
    view(player, lanePc)
end
```

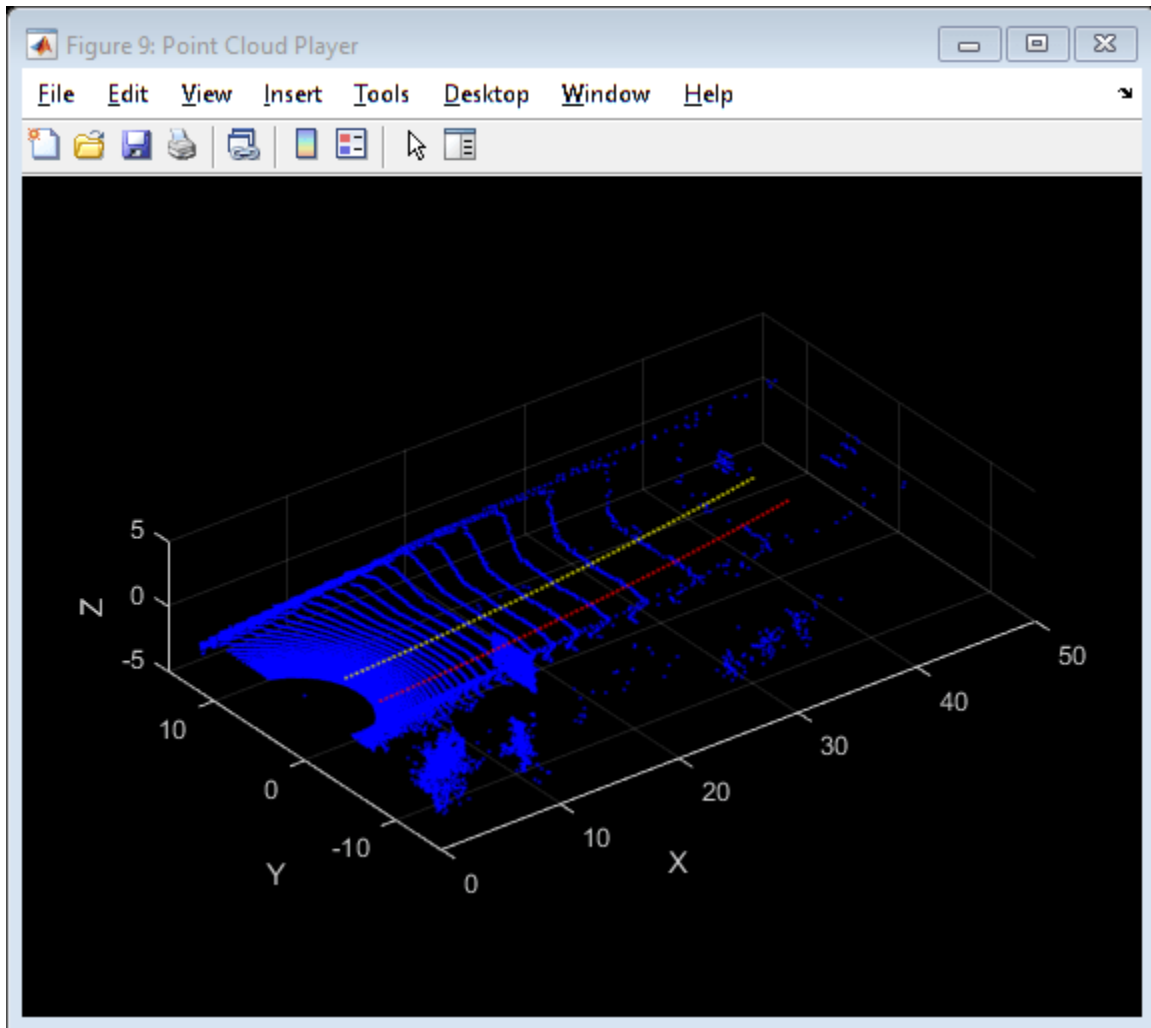

## Results

To analyze the lane detection results, compare them against the tracked lane polynomials by plotting them in figures. Each plot compares the parameters with and without the Kalman filter. The first plot compares the drift of lanes along the Y-axis, and the second plot compares the smoothness of the lane polynomials. Smoothness is defined as the rate of change of the slope of the lane curve.

```
figure
plot(drift)
hold on
plot(filteredDrift)
hold off
title('Lane Drift Along Y-axis')
legend('Drift Values','Filtered Drift Values')
```

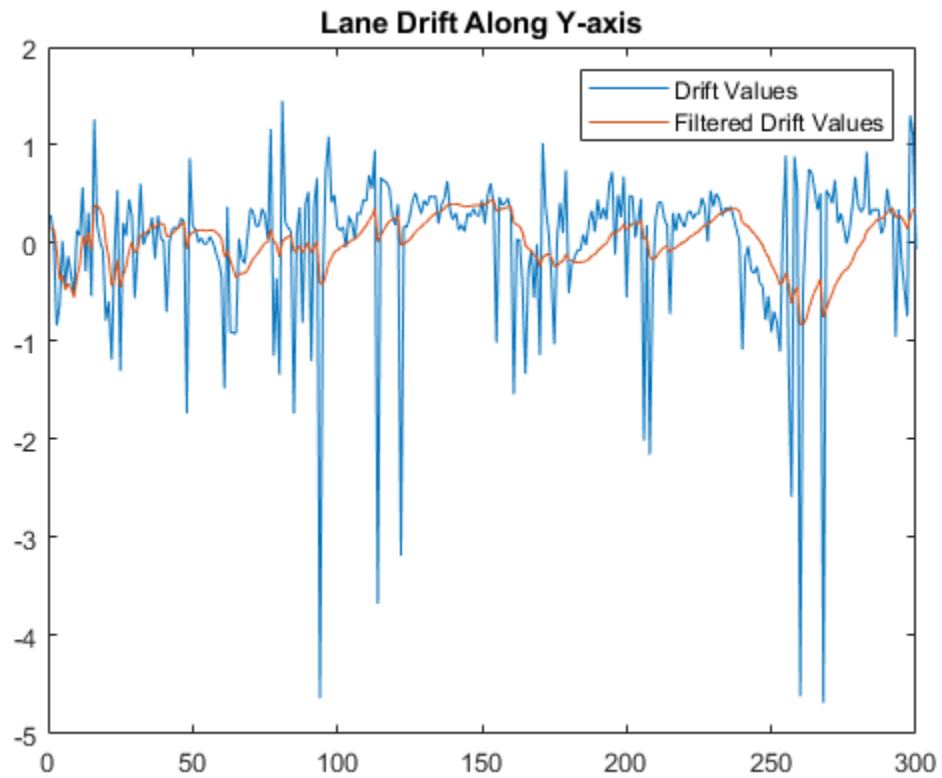

```
figure
plot(curveSmoothness)
hold on
plot(filteredCurveSmoothness)
hold off
title('Curve Smoothness')
legend('Curve Smoothness','Filtered Curve Smoothness')
```

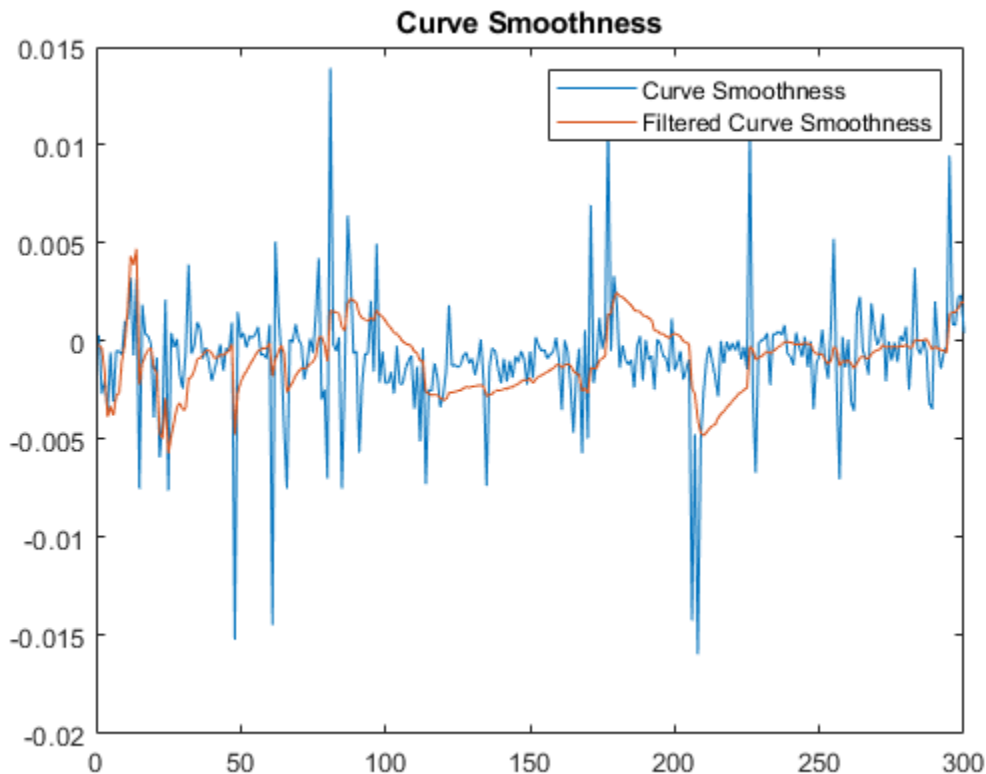

### Summary

This example has shown you how to detect lanes on the intensity channel of point clouds coming from lidar sensor. You have also learned how to fit a 2-D polynomial on detected lane points, and leverage ground plane model to estimate 3-D lane points. You have also used Kalman filter tracking to further improve lane detection.

### Supporting Functions

The helperLoadData helper function loads the lidar data set into the MATLAB workspace.

```
function reflidarData = helperGetDataset()
lidarDataTarFile = matlab.internal.examples.downloadSupportFile( ...
    'lidar','data/WPI_LidarData.tar.gz');
[outputFolder,~,~] = fileparts(lidarDataTarFile);

% Check if tar.gz file is downloaded, but not uncompressed
if ~exist(fullfile(outputFolder,'WPI_LidarData.mat'),'file')
    untar(lidarDataTarFile,outputFolder);
end

% Load lidar data
load(fullfile(outputFolder,'WPI_LidarData.mat'),'lidarData');

% Select region with a prominent intensity value
reflidarData = cell(300,1);
count = 1;
```



```

roi = [-50 50 -30 30 -inf inf];
for i = 81:380
    pc = lidarData{i};
    ind = findPointsInROI(pc,roi);
    reflidarData{count} = select(pc,ind);
    count = count+1;
end
end

```

This `helperInitialWindow` helper function computes the starting points of the search window using the detected histogram peaks.

```

function [yval,detectedPeaks] = helperInitialWindow(yvals,peaks,laneWidth)
leftLanesIndices = yvals >= 0;
rightLanesIndices = yvals < 0;
leftLaneYs = yvals(leftLanesIndices);
rightLaneYs = yvals(rightLanesIndices);
peaksLeft = peaks(leftLanesIndices);
peaksRight = peaks(rightLanesIndices);
diff = zeros(sum(leftLanesIndices),sum(rightLanesIndices));
for i = 1:sum(leftLanesIndices)
    for j = 1:sum(rightLanesIndices)
        diff(i,j) = abs(laneWidth - (leftLaneYs(i) - rightLaneYs(j)));
    end
end
[~,minIndex] = min(diff(:));
[row,col] = ind2sub(size(diff),minIndex);
yval = [leftLaneYs(row) rightLaneYs(col)];
detectedPeaks = [peaksLeft(row) peaksRight(col)];
estimatedLaneWidth = leftLaneYs(row) - rightLaneYs(col);

% If the calculated lane width is not within the bounds,
% return the lane with highest peak
if abs(estimatedLaneWidth - laneWidth) > 0.5
    if max(peaksLeft) > max(peaksRight)
        yval = [leftLaneYs(maxLeftInd) NaN];
        detectedPeaks = [peaksLeft(maxLeftInd) NaN];
    else
        yval = [NaN rightLaneYs(maxRightInd)];
        detectedPeaks = [NaN rightLaneYs(maxRightInd)];
    end
end
end
end

```

This `helperFitPolynomial` helper function fits a RANSAC-based polynomial to the detected lane points and computes the fitting score.

```

function [P,score] = helperFitPolynomial(pts,degree,resolution)
P = fitPolynomialRANSAC(pts,degree,resolution);
ptsSquare = (polyval(P,pts(:,1)) - pts(:,2)).^2;
score = sqrt(mean(ptsSquare));
end

```

This `helperComputeHistogram` helper function computes the histogram of the intensity values of the point clouds.

```

function [histVal,yvals] = helperComputeHistogram(ptCloud,histogramBinResolution)
numBins = ceil((ptCloud.YLimits(2) - ptCloud.YLimits(1))/histogramBinResolution);

```

```
histVal = zeros(1,numBins-1);
binStartY = linspace(ptCloud.YLimits(1),ptCloud.YLimits(2),numBins);
yvals = zeros(1,numBins-1);
for i = 1:numBins-1
    roi = [-inf 15 binStartY(i) binStartY(i+1) -inf inf];
    ind = findPointsInROI(ptCloud,roi);
    subPc = select(ptCloud,ind);
    if subPc.Count
        histVal(i) = sum(subPc.Intensity);
        yvals(i) = (binStartY(i) + binStartY(i+1))/2;
    end
end
end
```

This helper `findpeaks` helper function extracts peaks from the histogram values.

```
function [pkHistVal,pkIdx] = helperfindpeaks(histVal)
pkIdxTemp = (1:size(histVal,2))';
histValTemp = [NaN; histVal'; NaN];
tempIdx = (1:length(histValTemp)).';

% keep only the first of any adjacent pairs of equal values (including NaN)
yFinite = ~isnan(histValTemp);
iNeq = [1; 1 + find((histValTemp(1:end-1) ~= histValTemp(2:end)) & ...
    (yFinite(1:end-1) | yFinite(2:end)))];
tempIdx = tempIdx(iNeq);

% Take the sign of the first sample derivative
s = sign(diff(histValTemp(tempIdx)));

% Find local maxima
maxIdx = 1 + find(diff(s) < 0);

% Index into the original index vector without the NaN bookend
pkIdx = tempIdx(maxIdx) - 1;

% Fetch the coordinates of the peak
pkHistVal = histVal(pkIdx);
pkIdx = pkIdxTemp(pkIdx)';
end
```

## References

- [1] Ghallabi, Farouk, Fawzi Nashashibi, Ghayath El-Haj-Shhade, and Marie-Anne Mittet. "LIDAR-Based Lane Marking Detection for Vehicle Positioning in an HD Map." In 2018 21st International Conference on Intelligent Transportation Systems (ITSC), 2209-14. Maui: IEEE, 2018. <https://doi.org/10.1109/ITSC.2018.8569951>.
- [2] Thuy, Michael and Fernando León. "Lane Detection and Tracking Based on Lidar Data." *Metrology and Measurement Systems* 17, no. 3 (2010): 311-322. <https://doi.org/10.2478/v10178-010-0027-3>.

# Automate Ground Truth Labeling For Vehicle Detection Using PointPillars

This example shows how to automate vehicle detections in a point cloud using a pretrained `pointPillarsObjectDetector` in the Lidar Labeler. The example uses the `AutomationAlgorithm` interface in the **Lidar Labeler** app to automate labeling.

## Lidar Labeler App

Good ground truth data is crucial for the developing automated driving algorithms and evaluating performance. However, creating and maintaining a diverse, high-quality, and labeled data set requires significant effort. The **Lidar Labeler** app provides a framework to automate the labeling process using the `AutomationAlgorithm` interface. You can create a custom algorithm and use it in the app to label your entire data set. You can also edit the results to accommodate any challenging scenarios missed by the algorithm.

In this example, you:

- 1 Use a pretrained `pointPillarsObjectDetector` to detect objects of class 'vehicle'.
- 2 Create an automation algorithm that you can use in the **Lidar Labeler** app to automatically label vehicles in the point cloud using the PointPillars object detector.

## Detect Vehicles Using PointPillars Object Detector

Detect vehicles in a point cloud using a pretrained PointPillars object detector. For information on how to train a PointPillars network, see “Lidar 3-D Object Detection Using PointPillars Deep Learning” on page 1-189 example. You can improve the network performance by iteratively using custom training data while training the network.

Use the pretrained object detector to detect the vehicles:

- Read the point cloud.
- Run the detector on the point cloud to detect bounding boxes.
- Display the point cloud with bounding boxes.

```
% Load pretrained detector.
pretrainedDetector = load("pretrainedPointPillarsDetector.mat","detector");
detector = pretrainedDetector.detector;

% Read the point cloud.
ptCloud = pcread("PandasetLidarData.pcd");

% Detect the bounding boxes.
[bboxes,~,~] = detect(detector,ptCloud);

% Display the detections on the point cloud.
figure
ax = pcshow(ptCloud.Location);
showShape("cuboid",bboxes,"Parent",ax,"Opacity",0.1,"Color","green","LineWidth",0.5)
hold on
zoom(ax,2.5)
title("Detected vehicles on Point Cloud")
```

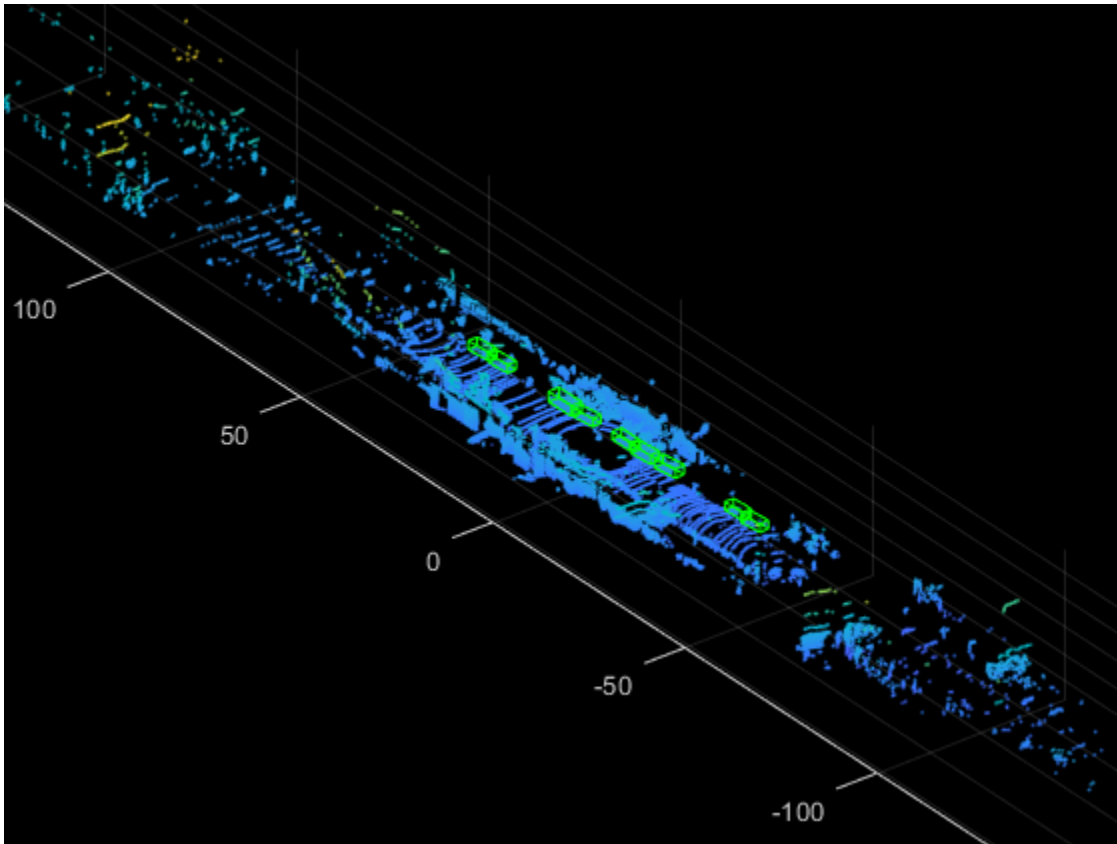

### Prepare Lidar Vehicle Detector Automation Class

Construct an automation class for the lidar vehicle detector algorithm. The class inherits from the `lidar.labeler.AutomationAlgorithm` abstract base class. The base class defines properties and signatures for methods that the app uses to configure and run the custom algorithm. The **Lidar Labeler** app provides an initial automation class template. For more information, see “Create Automation Algorithm for Labeling” on page 2-17. The `LidarVehicleDetector` class is based on this template and provides you with a ready-to-use automation class for vehicle detection in a point cloud. The comments of the class outline the basic steps needed to implement each API call.

### Algorithm Properties

Step 1 contains properties that define the name and description of the algorithm and the directions for using the algorithm.

```
% -----
% Step 1: Define the required properties describing the algorithm. This
% includes Name, Description, and UserDirections.
properties(Constant)

    % Name Algorithm Name
    % Character vector specifying the name of the algorithm.
    Name = 'Lidar Vehicle Detector';

    % Description Algorithm Description
    % Character vector specifying the short description of the algorithm.
    Description = 'Detect vehicles in point cloud using the pretrained PointPillars object d
```

```

% UserDirections Algorithm Usage Directions
% Cell array of character vectors specifying directions for
% algorithm users to follow to use the algorithm.
UserDirections = {'ROI Label Definition Selection: select one of ' ...
    'the ROI definitions to be labeled'}, ...
    ['Run: Press RUN to run the automation algorithm. '], ...
    ['Review and Modify: Review automated labels over the interval ', ...
    'using playback controls. Modify/delete/add ROIs that were not ' ...
    'satisfactorily automated at this stage. If the results are ' ...
    'satisfactory, click Accept to accept the automated labels.'], ...
    ['Change Settings and Rerun: If automated results are not ' ...
    'satisfactory, you can try to re-run the algorithm with ' ...
    'different settings. To do so, click Undo Run to undo ' ...
    'current automation run, click Settings, make changes to Settings,' ...
    'and press Run again.'], ...
    ['Accept/Cancel: If the results of automation are satisfactory, ' ...
    'click Accept to accept all automated labels and return to ' ...
    'manual labeling. If the results of automation are not ' ...
    'satisfactory, click Cancel to return to manual labeling ' ...
    'without saving the automated labels.'];
end

```

### Custom Properties

Step 2 contains the custom properties needed for the core algorithm.

```

% -----
% Step 2: Define properties you want to use during the algorithm
% execution.
properties

    % SelectedLabelName
    % Name of the selected label. Vehicles detected by the algorithm
    % are assigned this variable name.
    SelectedLabelName

    % PretrainedDetector
    % PretrainedDetector saves the pretrained PointPillars object
    % detector.
    PretrainedDetector

    % ConfidenceThreshold
    % Specify the confidence threshold to use only detections with
    % confidence scores above this value.
    ConfidenceThreshold = 0.45;

end

```

### Function Definitions

Step 3 deals with function definitions.

The `checkSignalType` function checks if the signal data is supported for automation. The lidar vehicle detector supports signals of the type `PointCloud`.

```

function isValid = checkSignalType(signalType)
    % Only point cloud signal data is valid for the Lidar Vehicle

```

```
    % detector algorithm.
    isValid = (signalType == vision.labeler.loading.SignalType.PointCloud);
end
```

The `checkLabelDefinition` function checks if the label definition is the appropriate type for automation. The lidar vehicle detector requires the Cuboid label type.

```
function isValid = checkLabelDefinition(~,labelDef)
    % Only cuboid ROI label definitions are valid for the Lidar
    % vehicle detector algorithm.
    isValid = labelDef.Type == labelType.Cuboid;
end
```

The `checkSetup` function checks if an ROI label definition is selected for automation.

```
function isReady = checkSetup(algObj)
    % Is there one selected ROI Label definition to automate.
    isReady = ~isempty(algObj.SelectedLabelDefinitions);
end
```

The `settingsDialog` function obtains and modifies the properties defined in Step 2. This API call lets you create a dialog box that opens when you click the **Settings** icon in the **Automate** tab. To create this dialog box, use the `dialog` function to quickly create a simple modal window to optionally modify the confidence threshold. The `lidarVehicleDetectorSettings` method contains the code for settings and input validation steps.

```
function settingsDialog(algObj)
    % Invoke dialog with option for modifying the confidence threshold.
    lidarVehicleDetectorSettings(algObj)
end
```

## Execution Functions

Step 4 specifies the execution functions. The `initialize` function populates the initial algorithm state based on the existing labels in the app. In this example, the `initialize` function performs the following steps:

- Store the name of the selected label definition.
- Load the pretrained `pointPillarsObjectDetector` and save it to the `PretrainedDetector` property.

```
function initialize(algObj,~)
    % Store the name of the selected label definition. Use this
    % name to label the detected vehicles.
    algObj.SelectedLabelName = algObj.SelectedLabelDefinitions.Name;

    % Load the pretrained pointPillarsObjectDetector.
    pretrainedDetector = load('pretrainedPointPillarsDetector.mat','detector');
    algObj.PretrainedDetector = pretrainedDetector.detector;
end
```

The `run` function defines the core lidar vehicle detector algorithm of this automation class. The `run` function is called for each frame of the point cloud sequence, and expects the automation class to return a set of labels. You can extend the algorithm to any category the network is trained on. In this example, the network detects the objects of class 'Vehicle'.

```
function autoLabels = run(algObj,pointCloud)
    bBoxes = [];
```

```

for i = 1:2
    if i == 2
        % Rotate the point cloud by 180 degrees.
        theta = pi;
        rot = [cos(theta) sin(theta) 0; ...
              -sin(theta) cos(theta) 0; ...
              0 0 1];
        trans = [0, 0, 0];
        tform = rigid3d(rot, trans);
        pointCloud = pctransform(pointCloud,tform);
    end

    % Detect the bounding boxes using the pretrained detector.
    [box,~,~] = detect(algObj.PretrainedDetector,pointCloud, ...
        "Threshold",algObj.ConfidenceThreshold);

    if ~isempty(box)
        if i == 2
            box(:,1) = -box(:,1);
            box(:,2) = -box(:,2);
            box(:,9) = -box(:,9);
        end
        bBoxes = [bBoxes;box];
    end
end

if ~isempty(bBoxes)
    % Add automated labels at bounding box locations detected
    % by the vehicle detector, of type Cuboid and with the name
    % of the selected label.
    autoLabels.Name = algObj.SelectedLabelName;
    autoLabels.Type = labelType.Cuboid;
    autoLabels.Position = bBoxes;
else
    autoLabels = [];
end
end
end

```

The `terminate` function handles any cleanup or tear-down required after the automation is done. This function is invoked after `run` has been invoked on the last frame in the specified interval or after algorithm stops running. `LidarVehicleDetector` algorithm does not require resetting any of its parameters, so the function is empty.

### Use Lidar Vehicle Detector Automation Class in App

Implement the properties and methods define earlier in the `LidarVehicleDetector` automation algorithm class file. Use the class in the **Lidar Labeler** app.

First, create the folder structure `+lidar/+labeler` under the current folder, and copy the automation class into the path.

```

mkdir('+lidar/+labeler');
copyfile(fullfile(matlabroot,'examples','lidar','main','LidarVehicleDetector.m'), ...
    '+lidar/+labeler');

```

Download the point cloud sequence (PCD). For illustration purposes, this example uses PandaSet data set from Hesai and Scale [1 on page 1-0 ]. PandaSet contains point cloud scans of the various city

scenes captured using the Pandar 64 sensor. Execute the following code block to download and save the lidar data in a temporary folder. Depending on your internet connection, the download process can take some time. The code suspends MATLAB® execution until the download process is complete. Alternatively, you can download the data set to your local disk using your web browser and extract the file.

Download the point cloud sequence to a temporary location.

```
outputFolder = fullfile(tempdir,'Pandaset');
lidarDataTarFile = fullfile(outputFolder,'Pandaset_LidarData.tar.gz');

if ~exist(lidarDataTarFile,'file')
    mkdir(outputFolder);
    disp('Downloading Pandaset Lidar driving data (5.2BG)...');
    component = 'lidar';
    filename = 'data/Pandaset_LidarData.tar.gz';
    lidarDataTarFile = matlab.internal.examples.downloadSupportFile(component,filename);
    untar(lidarDataTarFile,outputFolder);
end

% Check if tar.gz file is downloaded, but not uncompressed.
if ~exist(fullfile(outputFolder,'Lidar'),'file')
    untar(lidarDataTarFile,outputFolder);
end
```

Open the **Lidar Labeler** app and load the point cloud sequence.

```
pointCloudDir = fullfile(outputFolder,'Lidar');
lidarLabeler(pointCloudDir);
```

App displays the point cloud data and the time range as the image below.



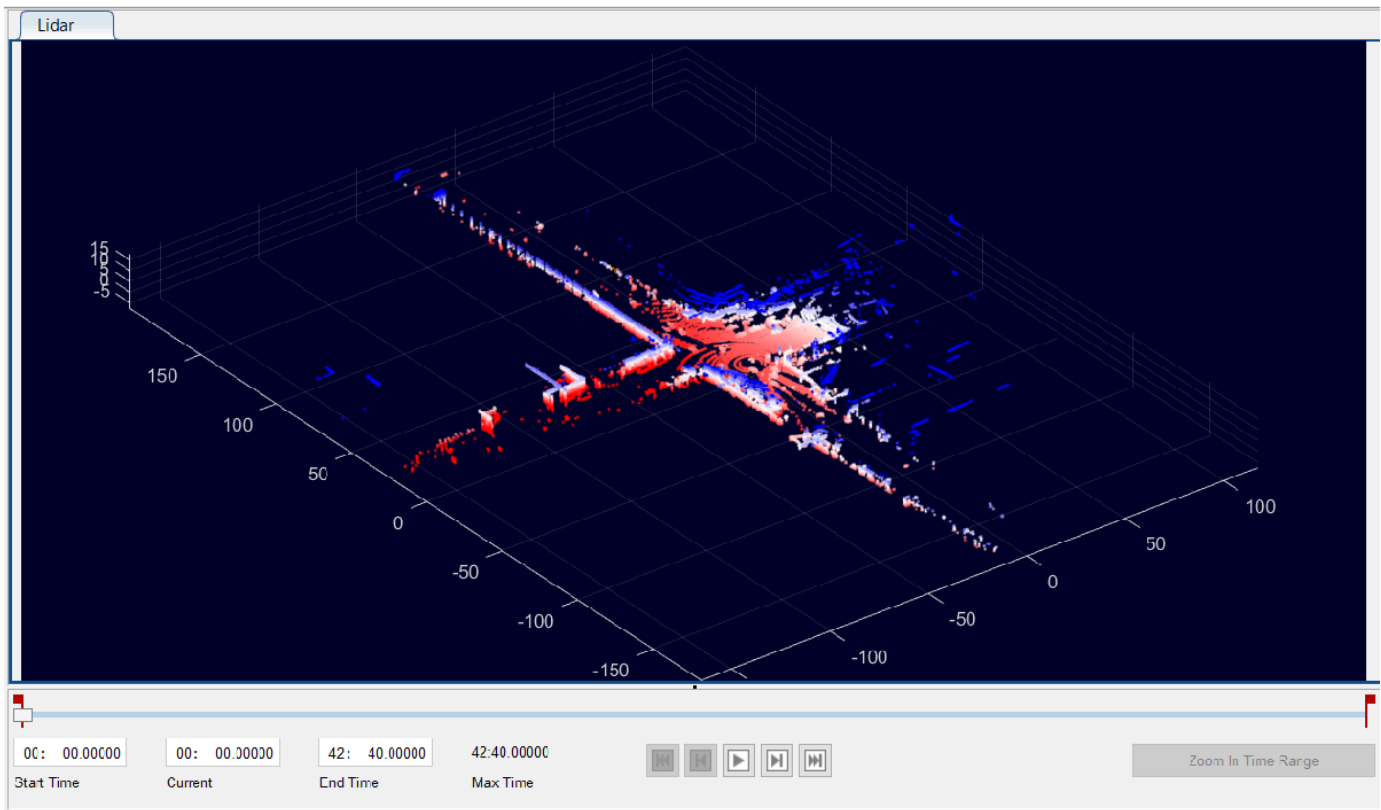

In the **ROI Labels** tab in the left pane, click **Label**. Define an ROI label with the name `Vehicle` and the `Cuboid`. Optionally, you can select a color. Click **OK**.

The dialog box titled "Define New ROI Label" contains the following fields and controls:

- Label Name:** A text input field containing "Vehicle".
- Color:** A dropdown menu showing "Cuboid" and a color selection box with a cyan color.
- Group:** A dropdown menu showing "None".
- Label Description (Optional):** A text area for entering a description.
- Buttons:** "OK" and "Cancel" buttons at the bottom.

This example runs the algorithm on a subset of the Pandaset point cloud frames. Specify the time interval from 0 to 15 seconds for which the app runs the algorithm. Specify 15 in the **End Time** box. The range slider and text boxes are set from 0 to 15 seconds. The app displays and applies the automation algorithm only on the frames in this interval.

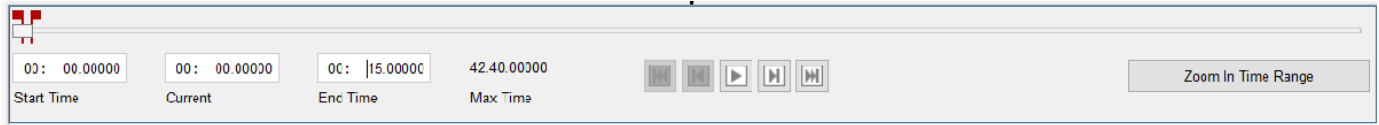

Under **Select Algorithm**, select **Refresh list**. Then, click on **Select Algorithm** and select **Lidar Vehicle Detector**. If you do not see this option, verify that the current working folder has a folder called +lidar/+labeler, with a file named LidarVehicleDetector.m in it.

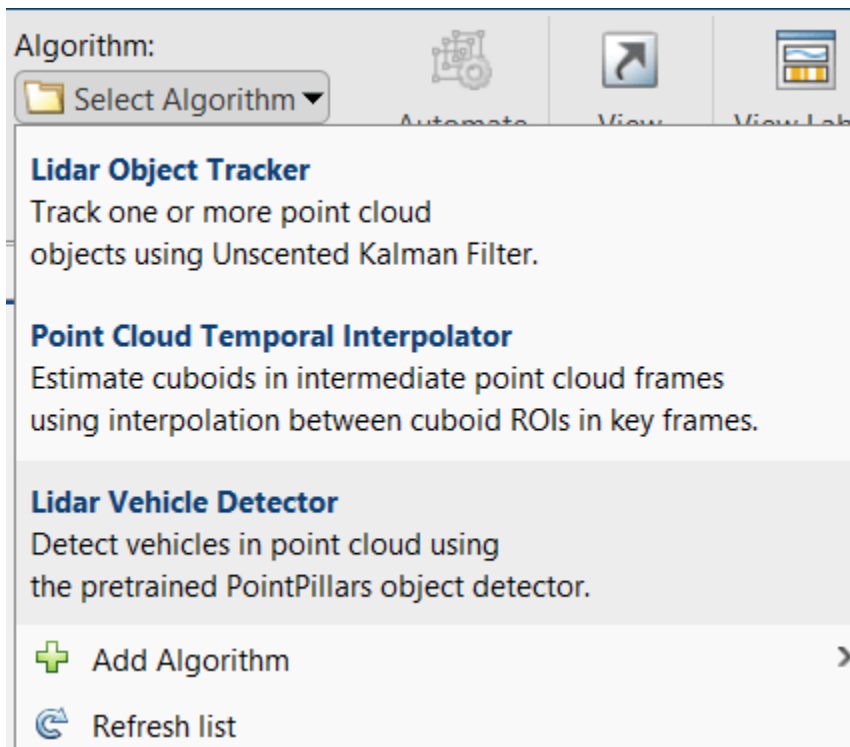

Click on **Automate**. The app opens an automation session for the selected signals and displays instructions to use the algorithm.

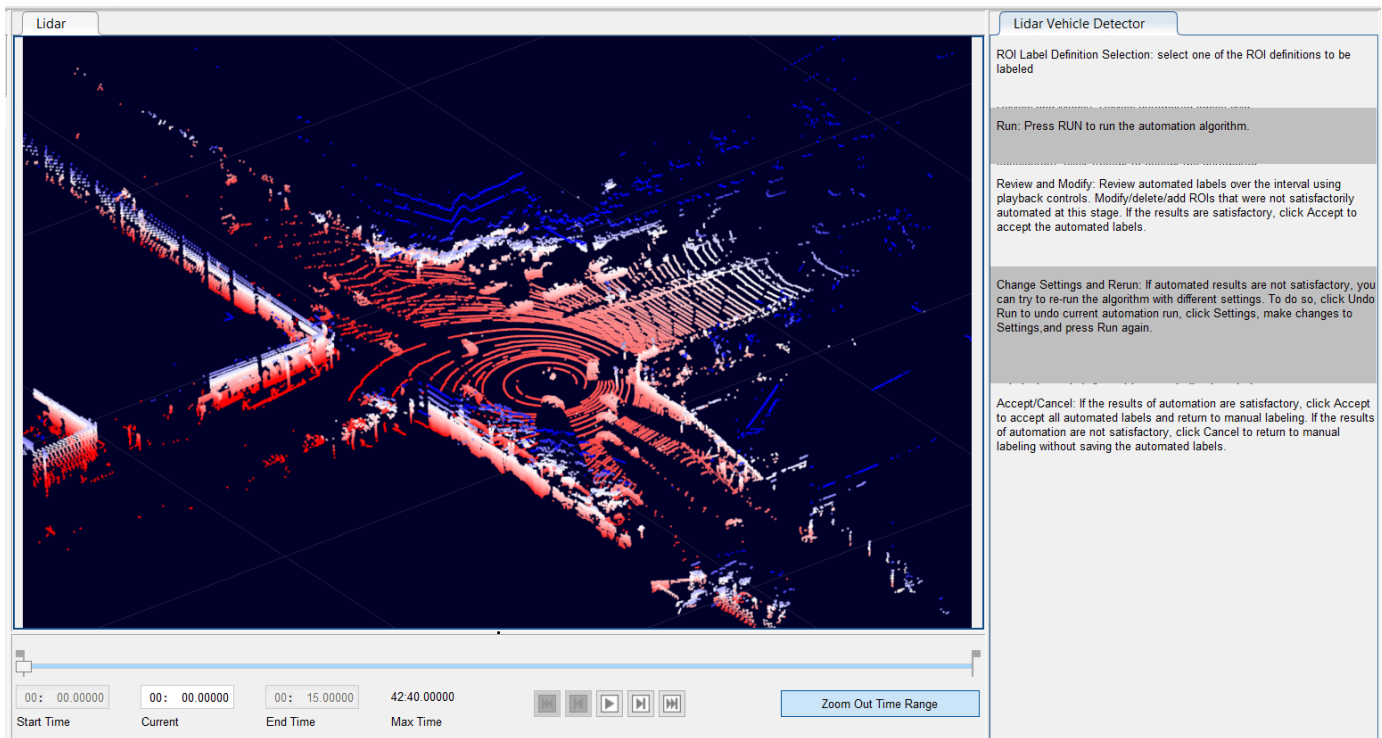

Click **Settings**, and in the dialog box that opens, modify the parameters if needed and click **OK**.

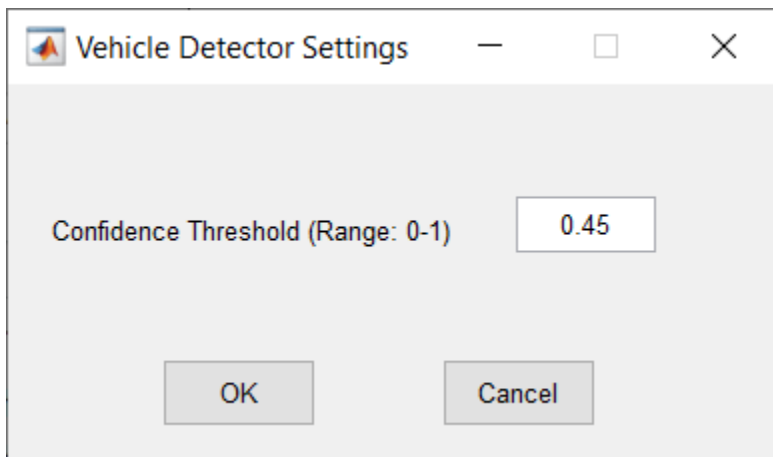

Click on **Run**. The app runs the algorithm on each frame of the sequence and detects vehicles by using the `Vehicle` label type. After the app completes the automation run, you can use the slider or arrow keys to scroll through the sequence to visualize the results or segmented labels. Use the zoom, pan, and 3-D rotation options to view and rotate the point cloud. You can manually tweak the results by adjusting the detected bounding boxes or adding new bounding boxes.

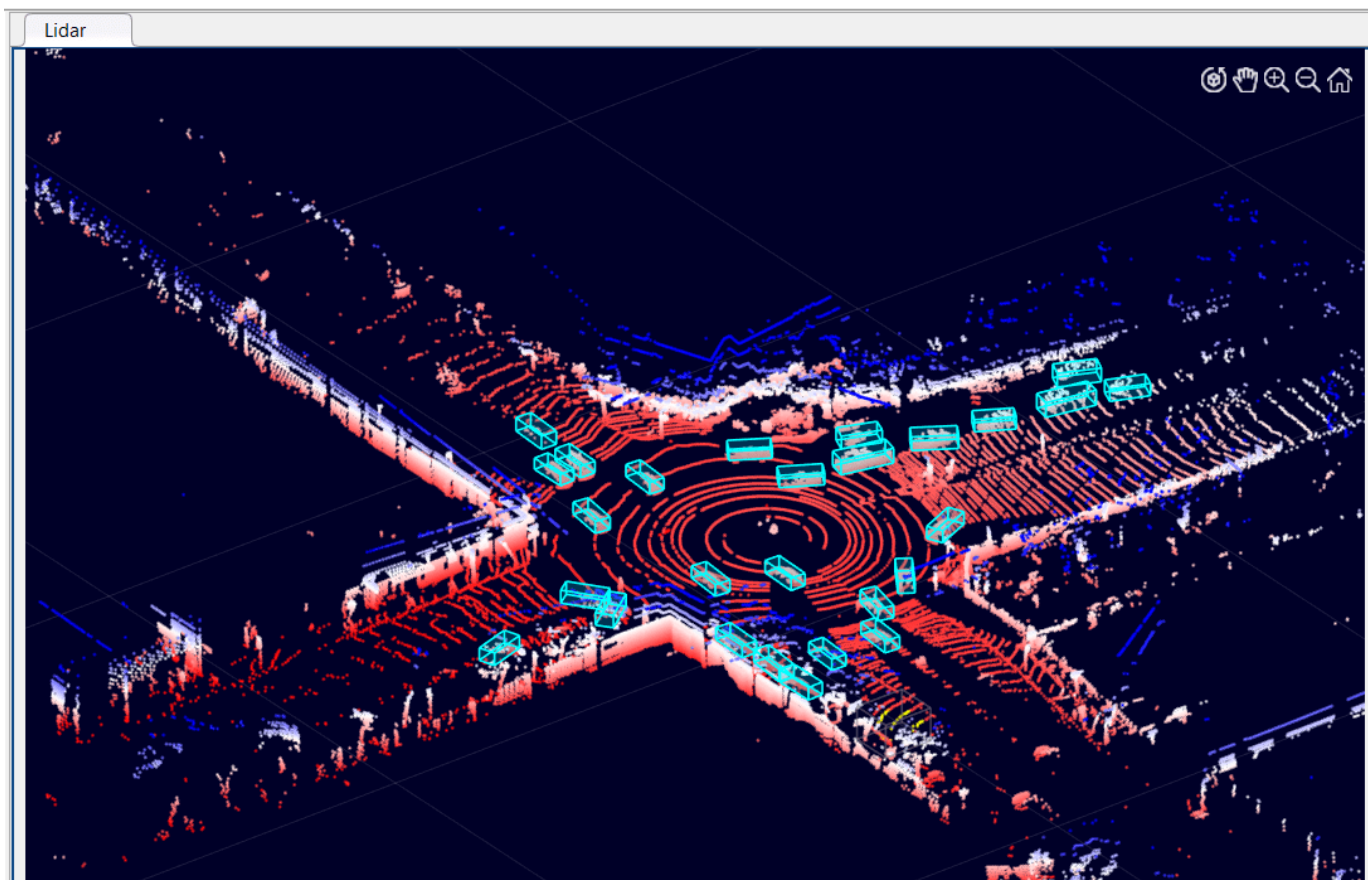

When you are satisfied with the detected vehicle bounding boxes for the entire sequence, click **Accept**. You can then continue to manually adjust labels or export the labeled ground truth to the MATLAB workspace.

You can use the concepts described in this example to create your own custom automation algorithms and extend the functionality of the app.

## References

[1] Hesai and Scale. PandaSet. <https://scale.com/open-datasets/pandaset>

## Track-Level Fusion of Radar and Lidar Data

This example shows you how to generate an object-level track list from measurements of a radar and a lidar sensor and further fuse them using a track-level fusion scheme. You process the radar measurements using an extended object tracker and the lidar measurements using a joint probabilistic data association (JPDA) tracker. You further fuse these tracks using a track-level fusion scheme. The schematic of the workflow is shown below.

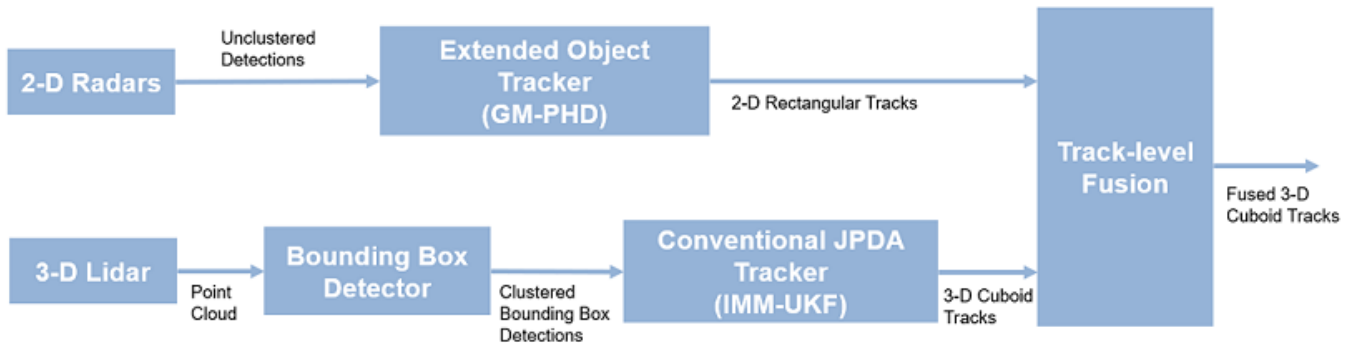

See “Fusion of Radar and Lidar Data Using ROS” (ROS Toolbox) for an example of this algorithm using recorded data on a rosbag.

### Setup Scenario for Synthetic Data Generation

The scenario used in this example is created using `drivingScenario` (Automated Driving Toolbox). The data from radar and lidar sensors is simulated using `drivingRadarDataGenerator` (Automated Driving Toolbox) and `lidarPointCloudGenerator` (Automated Driving Toolbox), respectively. The creation of the scenario and the sensor models is wrapped in the helper function `helperCreateRadarLidarScenario`. For more information on scenario and synthetic data generation, refer to “Create Driving Scenario Programmatically” (Automated Driving Toolbox).

```
% For reproducible results
rng(2021);
```

```
% Create scenario, ego vehicle and get radars and lidar sensor
[scenario, egoVehicle, radars, lidar] = helperCreateRadarLidarScenario;
```

The ego vehicle is mounted with four 2-D radar sensors. The front and rear radar sensors have a field of view of 45 degrees. The left and right radar sensors have a field of view of 150 degrees. Each radar has a resolution of 6 degrees in azimuth and 2.5 meters in range. The ego is also mounted with one 3-D lidar sensor with a field of view of 360 degrees in azimuth and 40 degrees in elevation. The lidar has a resolution of 0.2 degrees in azimuth and 1.25 degrees in elevation (32 elevation channels). Visualize the configuration of the sensors and the simulated sensor data in the animation below. Notice that the radars have higher resolution than objects and therefore return multiple measurements per object. Also notice that the lidar interacts with the low-poly mesh of the actor as well as the road surface to return multiple points from these objects.

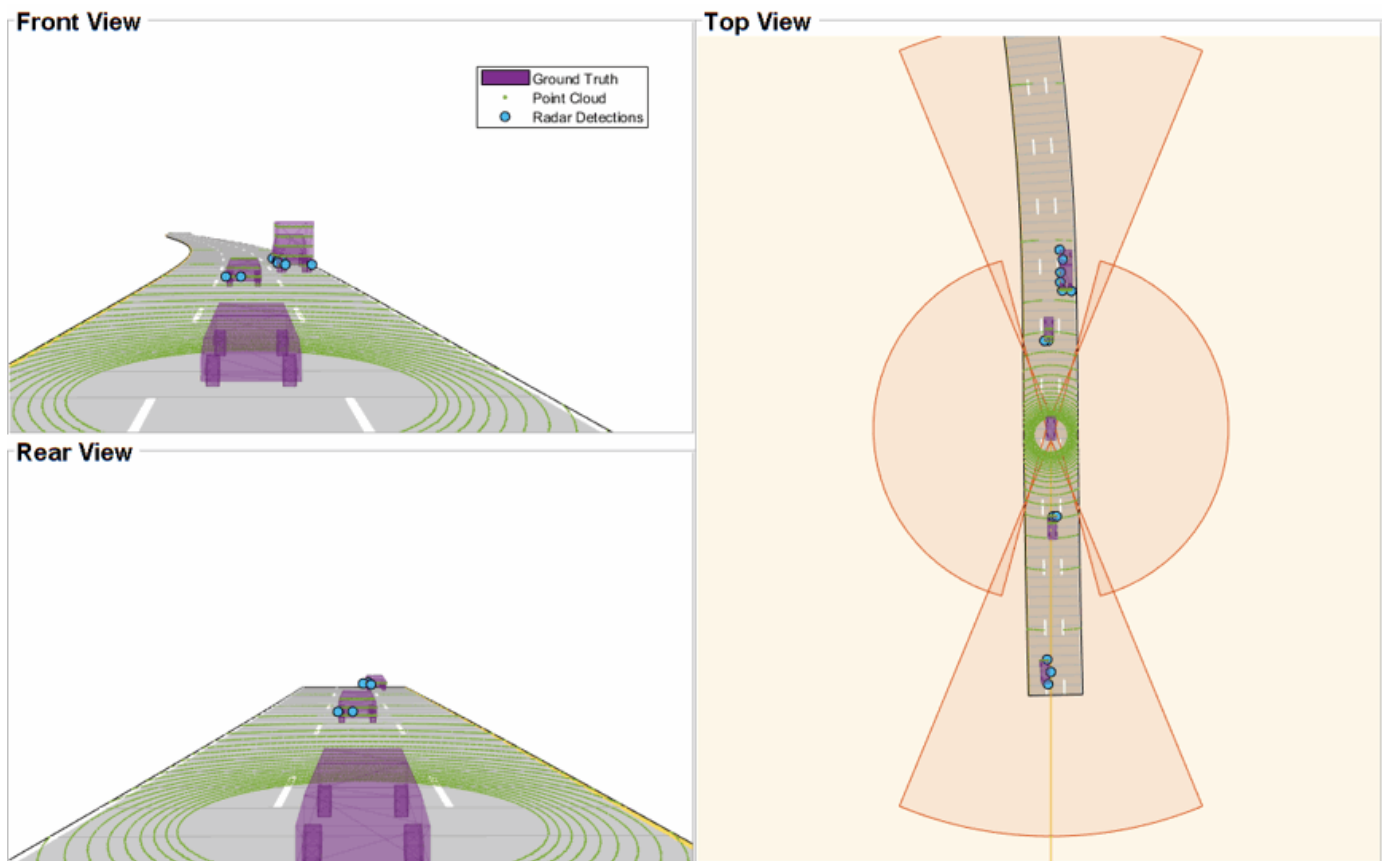

### Radar Tracking Algorithm

As mentioned, the radars have higher resolution than the objects and return multiple detections per object. Conventional trackers such as Global Nearest Neighbor (GNN) and Joint Probabilistic Data Association (JPDA) assume that the sensors return at most one detection per object per scan. Therefore, the detections from high-resolution sensors must be either clustered before processing it with conventional trackers or must be processed using extended object trackers. Extended object trackers do not require pre-clustering of detections and usually estimate both kinematic states (for example, position and velocity) and the extent of the objects. For a more detailed comparison between conventional trackers and extended object trackers, refer to the “Extended Object Tracking of Highway Vehicles with Radar and Camera” (Sensor Fusion and Tracking Toolbox) example.

In general, extended object trackers offer better estimation of objects as they handle clustering and data association simultaneously using temporal history of tracks. In this example, the radar detections are processed using a Gaussian mixture probability hypothesis density (GM-PHD) tracker (`trackerPHD` (Sensor Fusion and Tracking Toolbox) and `gmphd` (Sensor Fusion and Tracking Toolbox)) with a rectangular target model. For more details on configuring the tracker, refer to the “GM-PHD Rectangular Object Tracker” section of the “Extended Object Tracking of Highway Vehicles with Radar and Camera” (Sensor Fusion and Tracking Toolbox) example.

The algorithm for tracking objects using radar measurements is wrapped inside the helper class, `helperRadarTrackingAlgorithm`, implemented as a System object™. This class outputs an array of `objectTrack` (Sensor Fusion and Tracking Toolbox) objects and define their state according to the following convention:

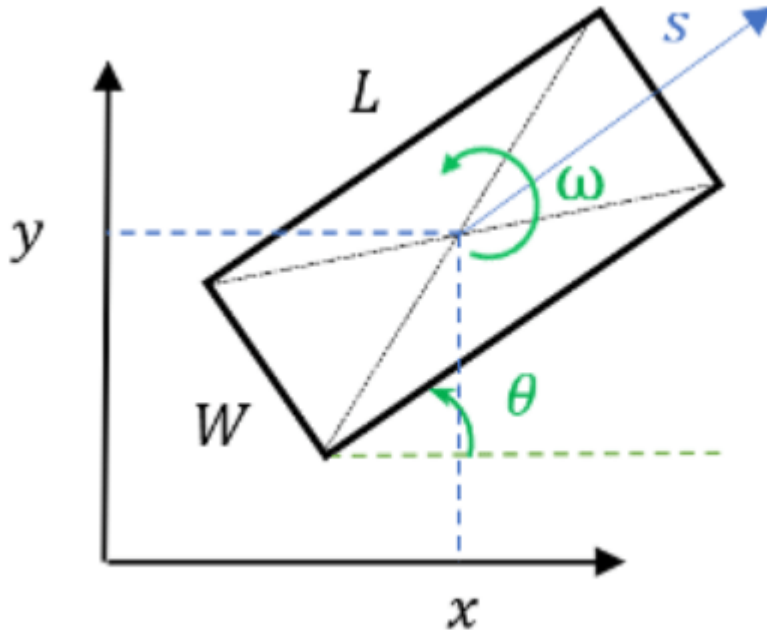
$[x \ y \ s \ \theta \ L \ W]$ 

```
radarTrackingAlgorithm = helperRadarTrackingAlgorithm(radars);
```

### Lidar Tracking Algorithm

Similar to radars, the lidar sensor also returns multiple measurements per object. Further, the sensor returns a large number of points from the road, which must be removed before used as inputs for an object-tracking algorithm. While lidar data from obstacles can be directly processed via extended object tracking algorithm, conventional tracking algorithms are still more prevalent for tracking using lidar data. The first reason for this trend is mainly observed due to higher computational complexity of extended object trackers for large data sets. The second reason is the investments into advanced Deep learning-based detectors such as PointPillars [1], VoxelNet [2] and PIXOR [3], which can segment a point cloud and return bounding box detections for the vehicles. These detectors can help in overcoming the performance degradation of conventional trackers due to improper clustering.

In this example, the lidar data is processed using a conventional joint probabilistic data association (JPDA) tracker, configured with an interacting multiple model (IMM) filter. The pre-processing of lidar data to remove point cloud is performed by using a RANSAC-based plane-fitting algorithm and bounding boxes are formed by performing a Euclidian-based distance clustering algorithm. For more information about the algorithm, refer to the “Track Vehicles Using Lidar: From Point Cloud to Track List” (Sensor Fusion and Tracking Toolbox) example. Compared the linked example, the tracking is performed in the scenario frame and the tracker is tuned differently to track objects of different sizes. Further the states of the variables are defined differently to constrain the motion of the tracks in the direction of its estimated heading angle.

The algorithm for tracking objects using lidar data is wrapped inside the helper class, `helperLidarTrackingAlgorithm` implemented as System object. This class outputs an array of



objectTrack (Sensor Fusion and Tracking Toolbox) objects and defines their state according to the following convention:

$$[x \ y \ s \ \theta \ \omega \ z \ \dot{z} \ L \ W \ H]$$

The states common to the radar algorithm are defined similarly. Also, as a 3-D sensor, the lidar tracker outputs three additional states,  $z$ ,  $\dot{z}$  and  $H$ , which refer to z-coordinate (m), z-velocity (m/s), and height (m) of the tracked object respectively.

```
lidarTrackingAlgorithm = helperLidarTrackingAlgorithm(lidar);
```

## Set Up Fuser, Metrics, and Visualization

### Fuser

Next, you will set up a fusion algorithm for fusing the list of tracks from radar and lidar trackers. Similar to other tracking algorithms, the first step towards setting up a track-level fusion algorithm is defining the choice of state vector (or state-space) for the fused or central tracks. In this case, the state-space for fused tracks is chosen to be same as the lidar. After choosing a central track state-space, you define the transformation of the central track state to the local track state. In this case, the local track state-space refers to states of radar and lidar tracks. To do this, you use a `fuserSourceConfiguration` (Sensor Fusion and Tracking Toolbox) object.

Define the configuration of the radar source. The `helperRadarTrackingAlgorithm` outputs tracks with `SourceIndex` set to 1. The `SourceIndex` is provided as a property on each tracker to uniquely identify it and allows a fusion algorithm to distinguish tracks from different sources. Therefore, you set the `SourceIndex` property of the radar configuration as same as those of the radar tracks. You set `IsInitializingCentralTracks` to `true` to let that unassigned radar tracks initiate new central tracks. Next, you define the transformation of a track in central state-space to the radar state-space and vice-versa. The helper functions `central2radar` and `radar2central` perform the two transformations and are included at the end of this example.

```
radarConfig = fuserSourceConfiguration('SourceIndex',1,...
    'IsInitializingCentralTracks',true,...
    'CentralToLocalTransformFcn',@central2radar,...
    'LocalToCentralTransformFcn',@radar2central);
```

Define the configuration of the lidar source. Since the state-space of a lidar track is same as central track, you do not define any transformations.

```
lidarConfig = fuserSourceConfiguration('SourceIndex',2,...
    'IsInitializingCentralTracks',true);
```

The next step is to define the state-fusion algorithm. The state-fusion algorithm takes multiple states and state covariances in the central state-space as input and returns a fused estimate of the state and the covariances. In this example, you use a covariance intersection algorithm provided by the helper function, `helperRadarLidarFusionFcn`. A generic covariance intersection algorithm for two Gaussian estimates with mean  $x_i$  and covariance  $P_i$  can be defined according to the following equations:

$$P_F^{-1} = w_1 P_1^{-1} + w_2 P_2^{-1}$$

$$x_F = P_F (w_1 P_1^{-1} x_1 + w_2 P_2^{-1} x_2)$$



where  $x_F$  and  $P_F$  are the fused state and covariance and  $w_1$  and  $w_2$  are mixing coefficients from each estimate. Typically, these mixing coefficients are estimated by minimizing the determinant or the trace of the fused covariance. In this example, the mixing weights are estimated by minimizing the determinant of positional covariance of each estimate. Furthermore, as the radar does not estimate 3-D states, 3-D states are only fused with lidars. For more details, refer to the `helperRadarLidarFusionFcn` function shown at the end of this script.

Next, you assemble all the information using a `trackFuser` object.

```
% The state-space of central tracks is same as the tracks from the lidar,
% therefore you use the same state transition function. The function is
% defined inside the helperLidarTrackingAlgorithm class.
f = lidarTrackingAlgorithm.StateTransitionFcn;

% Create a trackFuser object
fuser = trackFuser('SourceConfigurations',{radarConfig;lidarConfig},...
    'StateTransitionFcn',f,...
    'ProcessNoise',diag([1 3 1]),...
    'HasAdditiveProcessNoise',false,...
    'AssignmentThreshold',[250 inf],...
    'ConfirmationThreshold',[3 5],...
    'DeletionThreshold',[5 5],...
    'StateFusion','Custom',...
    'CustomStateFusionFcn',@helperRadarLidarFusionFcn);
```

## Metrics

In this example, you assess the performance of each algorithm using the Generalized Optimal SubPattern Assignment Metric (GOSPA) metric. You set up three separate metrics using `trackGOSPAMetric` (Sensor Fusion and Tracking Toolbox) for each of the trackers. The GOSPA metric aims to evaluate the performance of a tracking system by providing a scalar cost. A lower value of the metric indicates better performance of the tracking algorithm.

To use the GOSPA metric with custom motion models like the one used in this example, you set the `Distance` property to 'custom' and define a distance function between a track and its associated ground truth. These distance functions, shown at the end of this example are `helperRadarDistance`, and `helperLidarDistance`.

```
% Radar GOSPA
gospaRadar = trackGOSPAMetric('Distance','custom',...
    'DistanceFcn',@helperRadarDistance,...
    'CutoffDistance',25);

% Lidar GOSPA
gospaLidar = trackGOSPAMetric('Distance','custom',...
    'DistanceFcn',@helperLidarDistance,...
    'CutoffDistance',25);

% Central/Fused GOSPA
gospaCentral = trackGOSPAMetric('Distance','custom',...
    'DistanceFcn',@helperLidarDistance,...% State-space is same as lidar
    'CutoffDistance',25);
```

## Visualization

The visualization for this example is implemented using a helper class `helperLidarRadarTrackFusionDisplay`. The display is divided into 4 panels. The display plots

the measurements and tracks from each sensor as well as the fused track estimates. The legend for the display is shown below. Furthermore, the tracks are annotated by their unique identity (TrackID) as well as a prefix. The prefixes "R", "L" and "F" stand for radar, lidar, and fused estimate, respectively.

```
% Create a display.
% FollowActorID controls the actor shown in the close-up
% display
display = helperLidarRadarTrackFusionDisplay('FollowActorID',3);

% Show persistent legend
showLegend(display,scenario);
```

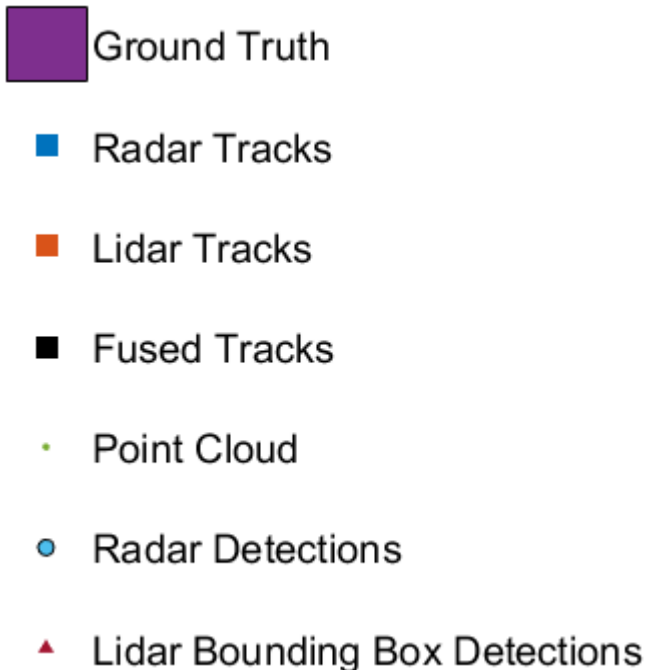

### Run Scenario and Trackers

Next, you advance the scenario, generate synthetic data from all sensors and process it to generate tracks from each of the systems. You also compute the metric for each tracker using the ground truth available from the scenario.

```
% Initialize GOSPA metric and its components for all tracking algorithms.
gospa = zeros(3,0);
missTarget = zeros(3,0);
falseTracks = zeros(3,0);

% Initialize fusedTracks
fusedTracks = objectTrack.empty(0,1);

% A counter for time steps elapsed for storing gospa metrics.
idx = 1;

% Ground truth for metrics. This variable updates every time-step
% automatically being a handle to the actors.
```

```

groundTruth = scenario.Operators(2:end);

while advance(scenario)
    % Current time
    time = scenario.SimulationTime;

    % Collect radar and lidar measurements and ego pose to track in
    % scenario frame. See helperCollectSensorData below.
    [radarDetections, ptCloud, egoPose] = helperCollectSensorData(egoVehicle, radars, lidar, time);

    % Generate radar tracks
    radarTracks = radarTrackingAlgorithm(egoPose, radarDetections, time);

    % Generate lidar tracks and analysis information like bounding box
    % detections and point cloud segmentation information
    [lidarTracks, lidarDetections, segmentationInfo] = ...
        lidarTrackingAlgorithm(egoPose, ptCloud, time);

    % Concatenate radar and lidar tracks
    localTracks = [radarTracks;lidarTracks];

    % Update the fuser. First call must contain one local track
    if ~(isempty(localTracks) && ~isLocked(fuser))
        fusedTracks = fuser(localTracks,time);
    end

    % Capture GOSPA and its components for all trackers
    [gospa(1,idx),~,~,~,missTarget(1,idx),falseTracks(1,idx)] = gospaRadar(radarTracks, groundTruth);
    [gospa(2,idx),~,~,~,missTarget(2,idx),falseTracks(2,idx)] = gospaLidar(lidarTracks, groundTruth);
    [gospa(3,idx),~,~,~,missTarget(3,idx),falseTracks(3,idx)] = gospaCentral(fusedTracks, groundTruth);

    % Update the display
    display(scenario, radars, radarDetections, radarTracks, ...
        lidar, ptCloud, lidarDetections, segmentationInfo, lidarTracks,...
        fusedTracks);

    % Update the index for storing GOSPA metrics
    idx = idx + 1;
end

% Update example animations
updateExampleAnimations(display);

```

### Evaluate Performance

Evaluate the performance of each tracker using visualization as well as quantitative metrics. Analyze different events in the scenario and understand how the track-level fusion scheme helps achieve a better estimation of the vehicle state.

### Track Maintenance

The animation below shows the entire run every three time-steps. Note that each of the three tracking systems - radar, lidar, and the track-level fusion - were able to track all four vehicles in the scenario and no false tracks were confirmed.

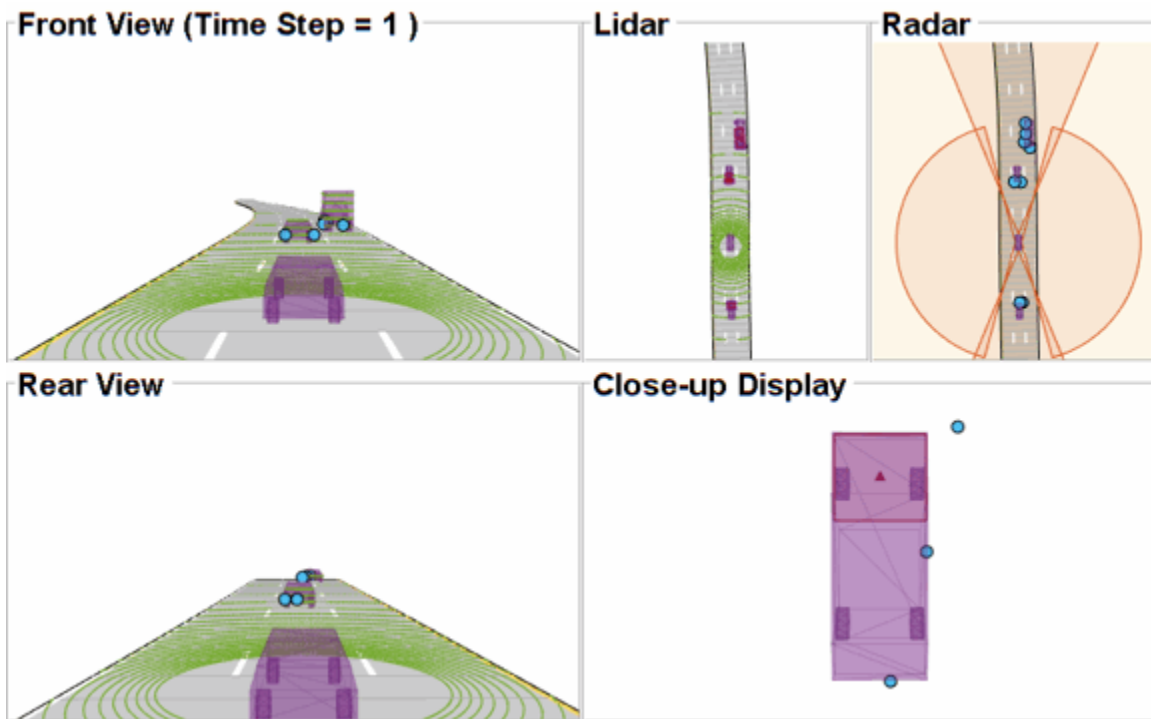

You can also quantitatively measure this aspect of the performance using "missed target" and "false track" components of the GOSPA metric. Notice in the figures below that missed target component starts from a higher value due to establishment delay and goes down to zero in about 5-10 steps for each tracking system. Also, notice that the false track component is zero for all systems, which indicates that no false tracks were confirmed.

```
% Plot missed target component
figure; plot(missTarget','LineWidth',2); legend('Radar','Lidar','Fused');
title("Missed Target Metric"); xlabel('Time step'); ylabel('Metric'); grid on;
```

```
% Plot false track component
figure; plot(falseTracks','LineWidth',2); legend('Radar','Lidar','Fused');
title("False Track Metric"); xlabel('Time step'); ylabel('Metric'); grid on;
```

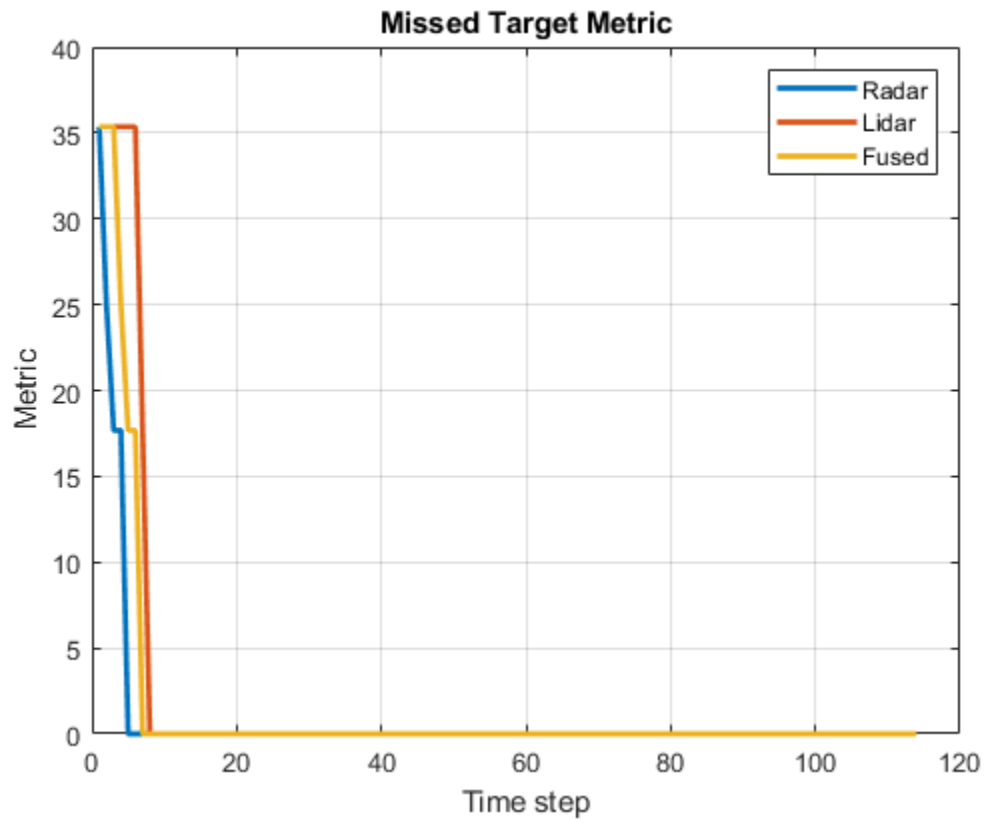

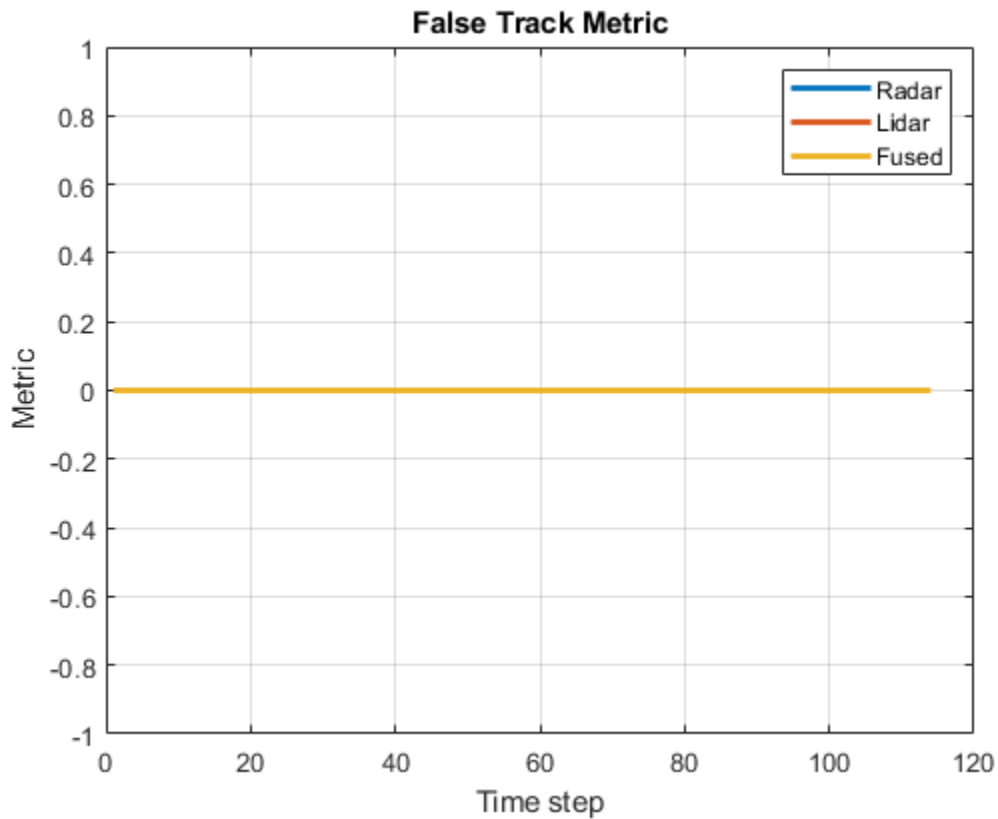

### Track-level Accuracy

The track-level or localization accuracy of each tracker can also be quantitatively assessed by the GOSPA metric at each time step. A lower value indicates better tracking accuracy. As there were no missed targets or false tracks, the metric captures the localization errors resulting from state estimation of each vehicle.

Note that the GOSPA metric for fused estimates is lower than the metric for individual sensor, which indicates that track accuracy increased after fusion of track estimates from each sensor.

```
% Plot GOSPA
figure; plot(gospa', 'LineWidth', 2); legend('Radar', 'Lidar', 'Fused');
title("GOSPA Metric"); xlabel('Time step'); ylabel('Metric'); grid on;
```

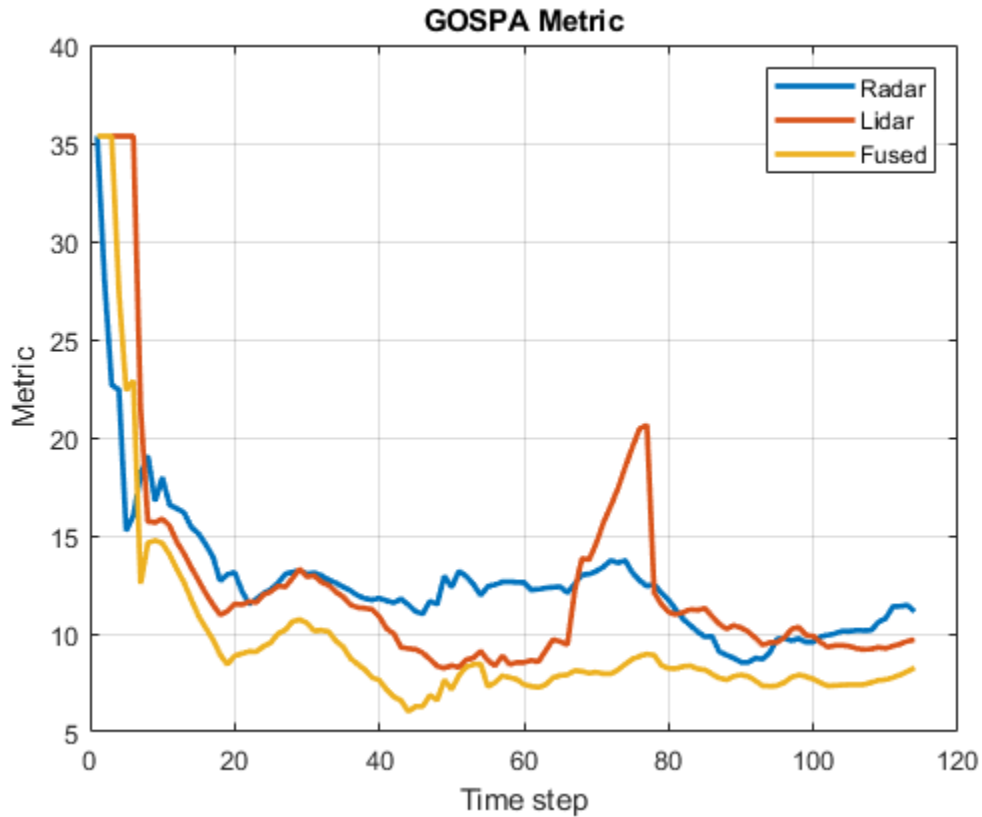

### Closely-spaced targets

As mentioned earlier, this example uses a Euclidian-distance based clustering and bounding box fitting to feed the lidar data to a conventional tracking algorithm. Clustering algorithms typically suffer when objects are closely-spaced. With the detector configuration used in this example, when the passing vehicle approaches the vehicle in front of the ego vehicle, the detector clusters the point cloud from each vehicle into a bigger bounding box. You can notice in the animation below that the track drifted away from the vehicle center. Because the track was reported with higher certainty in its estimate for a few steps, the fused estimated was also affected initially. However, as the uncertainty increases, its association with the fused estimate becomes weaker. This is because the covariance intersection algorithm chooses a mixing weight for each assigned track based on the certainty of each estimate.

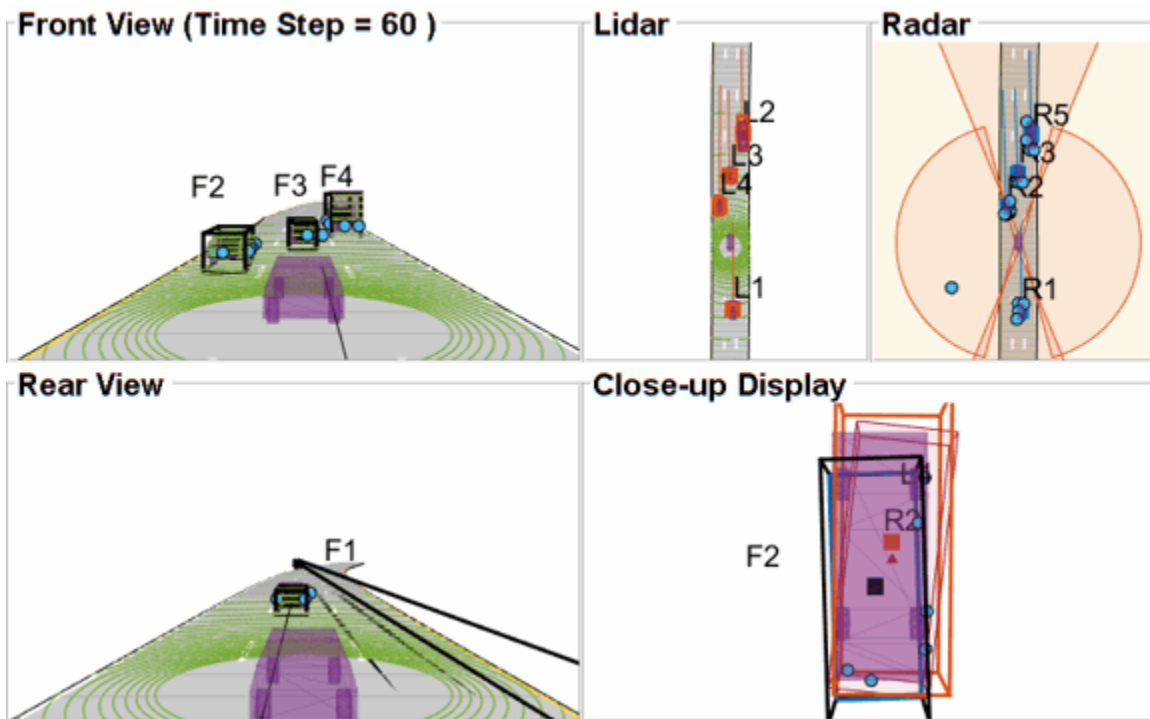

This effect is also captured in the GOSPA metric. You can notice in the GOSPA metric plot above that the lidar metric shows a peak around the 65th time step.

The radar tracks are not affected during this event because of two main reasons. Firstly, the radar sensor outputs range-rate information in each detection, which is different beyond noise-levels for the passing car as compared to the slower moving car. This results in an increased statistical distance between detections from individual cars. Secondly, extended object trackers evaluate multiple possible clustering hypothesis against predicted tracks, which results in rejection of improper clusters and acceptance of proper clusters. Note that for extended object trackers to properly choose the best clusters, the filter for the track must be robust to a degree that can capture the difference between two clusters. For example, a track with high process noise and highly uncertain dimensions may not be able to properly claim a cluster because of its premature age and higher flexibility to account for uncertain events.

### Targets at long range

As targets recede away from the radar sensors, the accuracy of the measurements degrade because of reduced signal-to-noise ratio at the detector and the limited resolution of the sensor. This results in high uncertainty in the measurements, which in turn reduces the track accuracy. Notice in the close-up display below that the track estimate from the radar is further away from the ground truth for the radar sensor and is reported with a higher uncertainty. However, the lidar sensor reports enough measurements in the point cloud to generate a "shrunk" bounding box. The shrinkage effect modeled in the measurement model for lidar tracking algorithm allows the tracker to maintain a track with correct dimensions. In such situations, the lidar mixing weight is higher than the radar and allows the fused estimate to be more accurate than the radar estimate.



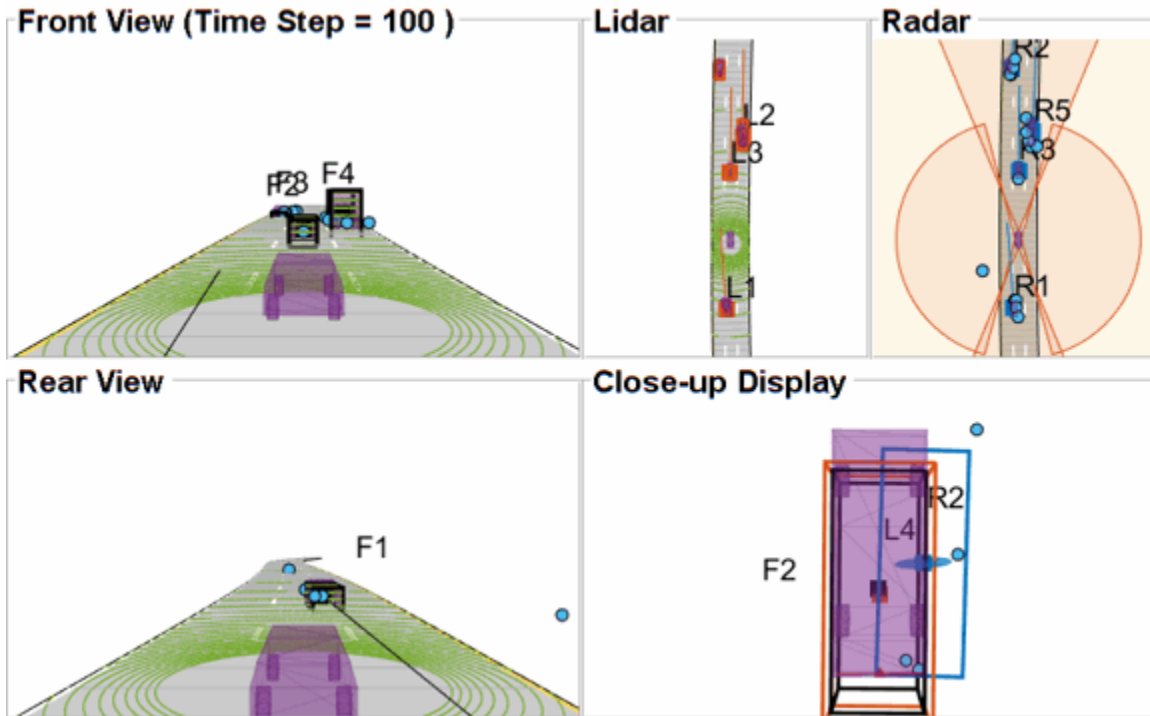

## Summary

In this example, you learned how to set up a track-level fusion algorithm for fusing tracks from radar and lidar sensors. You also learned how to evaluate a tracking algorithm using the Generalized Optimal Subpattern Metric and its associated components.

## Utility Functions

### collectSensorData

A function to generate radar and lidar measurements at the current time-step.

```
function [radarDetections, ptCloud, egoPose] = helperCollectSensorData(egoVehicle, radars, lidar)
% Current poses of targets with respect to ego vehicle
tgtPoses = targetPoses(egoVehicle);

radarDetections = cell(0,1);
for i = 1:numel(radars)
    thisRadarDetections = step(radars{i},tgtPoses,time);
    radarDetections = [radarDetections;thisRadarDetections]; %#ok<AGROW>
end

% Generate point cloud from lidar
rdMesh = roadMesh(egoVehicle);
ptCloud = step(lidar, tgtPoses, rdMesh, time);

% Compute pose of ego vehicle to track in scenario frame. Typically
% obtained using an INS system. If unavailable, this can be set to
% "origin" to track in ego vehicle's frame.
egoPose = pose(egoVehicle);
```

end

### radar2central

A function to transform a track in the radar state-space to a track in the central state-space.

```
function centralTrack = radar2central(radarTrack)

% Initialize a track of the correct state size
centralTrack = objectTrack('State',zeros(10,1),...
    'StateCovariance',eye(10));

% Sync properties of radarTrack except State and StateCovariance with
% radarTrack See syncTrack defined below.
centralTrack = syncTrack(centralTrack,radarTrack);

xRadar = radarTrack.State;
PRadar = radarTrack.StateCovariance;

H = zeros(10,7); % Radar to central linear transformation matrix
H(1,1) = 1;
H(2,2) = 1;
H(3,3) = 1;
H(4,4) = 1;
H(5,5) = 1;
H(8,6) = 1;
H(9,7) = 1;

xCentral = H*xRadar; % Linear state transformation
PCentral = H*PRadar*H'; % Linear covariance transformation

PCentral([6 7 10],[6 7 10]) = eye(3); % Unobserved states

% Set state and covariance of central track
centralTrack.State = xCentral;
centralTrack.StateCovariance = PCentral;

end
```

### central2radar

A function to transform a track in the central state-space to a track in the radar state-space.

```
function radarTrack = central2radar(centralTrack)

% Initialize a track of the correct state size
radarTrack = objectTrack('State',zeros(7,1),...
    'StateCovariance',eye(7));

% Sync properties of centralTrack except State and StateCovariance with
% radarTrack See syncTrack defined below.
radarTrack = syncTrack(radarTrack,centralTrack);

xCentral = centralTrack.State;
PCentral = centralTrack.StateCovariance;

H = zeros(7,10); % Central to radar linear transformation matrix
```

```

H(1,1) = 1;
H(2,2) = 1;
H(3,3) = 1;
H(4,4) = 1;
H(5,5) = 1;
H(6,8) = 1;
H(7,9) = 1;

xRadar = H*xCentral; % Linear state transformation
PRadar = H*PCentral*H'; % Linear covariance transformation

% Set state and covariance of radar track
radarTrack.State = xRadar;
radarTrack.StateCovariance = PRadar;
end

```

### syncTrack

A function to syncs properties of one track with another except the State and StateCovariance properties.

```

function tr1 = syncTrack(tr1,tr2)
props = properties(tr1);
notState = ~strcmpi(props, 'State');
notCov = ~strcmpi(props, 'StateCovariance');

props = props(notState & notCov);
for i = 1:numel(props)
    tr1.(props{i}) = tr2.(props{i});
end
end

```

### pose

A function to return pose of the ego vehicle as a structure.

```

function egoPose = pose(egoVehicle)
egoPose.Position = egoVehicle.Position;
egoPose.Velocity = egoVehicle.Velocity;
egoPose.Yaw = egoVehicle.Yaw;
egoPose.Pitch = egoVehicle.Pitch;
egoPose.Roll = egoVehicle.Roll;
end

```

### helperLidarDistance

Function to calculate a normalized distance between the estimate of a track in radar state-space and the assigned ground truth.

```

function dist = helperLidarDistance(track, truth)

% Calculate the actual values of the states estimated by the tracker

% Center is different than origin and the trackers estimate the center
rOriginToCenter = -truth.OriginOffset(:) + [0;0;truth.Height/2];
rot = quaternion([truth.Yaw truth.Pitch truth.Roll], 'eulerd', 'ZYX', 'frame');
actPos = truth.Position(:) + rotatepoint(rot, rOriginToCenter)';

```

```
% Actual speed and z-rate
actVel = [norm(truth.Velocity(1:2));truth.Velocity(3)];

% Actual yaw
actYaw = truth.Yaw;

% Actual dimensions.
actDim = [truth.Length;truth.Width;truth.Height];

% Actual yaw rate
actYawRate = truth.AngularVelocity(3);

% Calculate error in each estimate weighted by the "requirements" of the
% system. The distance specified using Mahalanobis distance in each aspect
% of the estimate, where covariance is defined by the "requirements". This
% helps to avoid skewed distances when tracks under/over report their
% uncertainty because of inaccuracies in state/measurement models.

% Positional error.
estPos = track.State([1 2 6]);
reqPosCov = 0.1*eye(3);
e = estPos - actPos;
d1 = sqrt(e'/reqPosCov*e);

% Velocity error
estVel = track.State([3 7]);
reqVelCov = 5*eye(2);
e = estVel - actVel;
d2 = sqrt(e'/reqVelCov*e);

% Yaw error
estYaw = track.State(4);
reqYawCov = 5;
e = estYaw - actYaw;
d3 = sqrt(e'/reqYawCov*e);

% Yaw-rate error
estYawRate = track.State(5);
reqYawRateCov = 1;
e = estYawRate - actYawRate;
d4 = sqrt(e'/reqYawRateCov*e);

% Dimension error
estDim = track.State([8 9 10]);
reqDimCov = eye(3);
e = estDim - actDim;
d5 = sqrt(e'/reqDimCov*e);

% Total distance
dist = d1 + d2 + d3 + d4 + d5;

end
```

### **helperRadarDistance**

Function to calculate a normalized distance between the estimate of a track in radar state-space and the assigned ground truth.

```

function dist = helperRadarDistance(track, truth)

% Calculate the actual values of the states estimated by the tracker

% Center is different than origin and the trackers estimate the center
rOriginToCenter = -truth.OriginOffset(:) + [0;0;truth.Height/2];
rot = quaternion([truth.Yaw truth.Pitch truth.Roll], 'eulerd', 'ZYX', 'frame');
actPos = truth.Position(:) + rotatepoint(rot,rOriginToCenter)';
actPos = actPos(1:2); % Only 2-D

% Actual speed
actVel = norm(truth.Velocity(1:2));

% Actual yaw
actYaw = truth.Yaw;

% Actual dimensions. Only 2-D for radar
actDim = [truth.Length;truth.Width];

% Actual yaw rate
actYawRate = truth.AngularVelocity(3);

% Calculate error in each estimate weighted by the "requirements" of the
% system. The distance specified using Mahalanobis distance in each aspect
% of the estimate, where covariance is defined by the "requirements". This
% helps to avoid skewed distances when tracks under/over report their
% uncertainty because of inaccuracies in state/measurement models.

% Positional error
estPos = track.State([1 2]);
reqPosCov = 0.1*eye(2);
e = estPos - actPos;
d1 = sqrt(e'/reqPosCov*e);

% Speed error
estVel = track.State(3);
reqVelCov = 5;
e = estVel - actVel;
d2 = sqrt(e'/reqVelCov*e);

% Yaw error
estYaw = track.State(4);
reqYawCov = 5;
e = estYaw - actYaw;
d3 = sqrt(e'/reqYawCov*e);

% Yaw-rate error
estYawRate = track.State(5);
reqYawRateCov = 1;
e = estYawRate - actYawRate;
d4 = sqrt(e'/reqYawRateCov*e);

% Dimension error
estDim = track.State([6 7]);
reqDimCov = eye(2);
e = estDim - actDim;
d5 = sqrt(e'/reqDimCov*e);

```

```
% Total distance
dist = d1 + d2 + d3 + d4 + d5;

% A constant penalty for not measuring 3-D state
dist = dist + 3;

end
```

### **helperRadarLidarFusionFcn**

Function to fuse states and state covariances in central track state-space

```
function [x,P] = helperRadarLidarFusionFcn(xAll,PAll)
n = size(xAll,2);
dets = zeros(n,1);

% Initialize x and P
x = xAll(:,1);
P = PAll(:, :, 1);

onlyLidarStates = false(10,1);
onlyLidarStates([6 7 10]) = true;

% Only fuse this information with lidar
xOnlyLidar = xAll(onlyLidarStates,:);
POnlyLidar = PAll(onlyLidarStates,onlyLidarStates,:);

% States and covariances for intersection with radar and lidar both
xToFuse = xAll(~onlyLidarStates,:);
PToFuse = PAll(~onlyLidarStates,~onlyLidarStates,:);

% Sorted order of determinants. This helps to sequentially build the
% covariance with comparable determinations. For example, two large
% covariances may intersect to a smaller covariance, which is comparable to
% the third smallest covariance.
for i = 1:n
    dets(i) = det(PToFuse(1:2,1:2,i));
end
[~,idx] = sort(dets,'descend');
xToFuse = xToFuse(:,idx);
PToFuse = PToFuse(:, :, idx);

% Initialize fused estimate
thisX = xToFuse(:,1);
thisP = PToFuse(:, :, 1);

% Sequential fusion
for i = 2:n
    [thisX,thisP] = fusecovintUsingPos(thisX, thisP, xToFuse(:,i), PToFuse(:, :, i));
end

% Assign fused states from all sources
x(~onlyLidarStates) = thisX;
P(~onlyLidarStates,~onlyLidarStates,:) = thisP;

% Fuse some states only with lidar source
valid = any(abs(xOnlyLidar) > 1e-6,1);
```

```

xMerge = xOnlyLidar(:,valid);
PMerge = POnlyLidar(:, :, valid);

if sum(valid) > 1
    [xL,PL] = fusecovint(xMerge,PMerge);
elseif sum(valid) == 1
    xL = xMerge;
    PL = PMerge;
else
    xL = zeros(3,1);
    PL = eye(3);
end

x(onlyLidarStates) = xL;
P(onlyLidarStates,onlyLidarStates) = PL;

end

function [x,P] = fusecovintUsingPos(x1,P1,x2,P2)
% Covariance intersection in general is employed by the following
% equations:
%  $P^{-1} = w_1 P_1^{-1} + w_2 P_2^{-1}$ 
%  $x = P(w_1 P_1^{-1} x_1 + w_2 P_2^{-1} x_2)$ ;
% where  $w_1 + w_2 = 1$ 
% Usually a scalar representative of the covariance matrix like "det" or
% "trace" of P is minimized to compute w. This is offered by the function
% "fusecovint". However. in this case, the w are chosen by minimizing the
% determinants of "positional" covariances only.
n = size(x1,1);
idx = [1 2];
detP1pos = det(P1(idx,idx));
detP2pos = det(P2(idx,idx));
w1 = detP2pos/(detP1pos + detP2pos);
w2 = detP1pos/(detP1pos + detP2pos);
I = eye(n);

P1inv = I/P1;
P2inv = I/P2;

Pinv = w1*P1inv + w2*P2inv;
P = I/Pinv;

x = P*(w1*P1inv*x1 + w2*P2inv*x2);

end

```

## References

- [1] Lang, Alex H., et al. "PointPillars: Fast encoders for object detection from point clouds." Proceedings of the IEEE Conference on Computer Vision and Pattern Recognition. 2019.
- [2] Zhou, Yin, and Oncel Tuzel. "Voxelnet: End-to-end learning for point cloud based 3d object detection." Proceedings of the IEEE Conference on Computer Vision and Pattern Recognition. 2018.

[3] Yang, Bin, Wenjie Luo, and Raquel Urtasun. "Pixor: Real-time 3d object detection from point clouds." Proceedings of the IEEE conference on Computer Vision and Pattern Recognition. 2018.



# Code Generation For Lidar Object Detection Using PointPillars Deep Learning

This example shows how to generate CUDA® MEX for a PointPillars object detector. For more information, see “Lidar 3-D Object Detection Using PointPillars Deep Learning” on page 1-189 example from the Lidar Toolbox™.

## Third-Party Prerequisites

### Required

- CUDA enabled NVIDIA® GPU and compatible driver.

### Optional

For non-MEX builds such as static and dynamic libraries or executables, this example has the following additional requirements.

- NVIDIA CUDA toolkit.
- NVIDIA cuDNN library.
- Environment variables for the compilers and libraries. For more information, see “Third-Party Hardware” (GPU Coder) and “Setting Up the Prerequisite Products” (GPU Coder).

## Verify GPU Environment

To verify that the compilers and libraries for running this example are set up correctly, use the `coder.checkGpuInstall` (GPU Coder) function.

```
envCfg = coder.gpuEnvConfig('host');
envCfg.DeepLibTarget = 'cudnn';
envCfg.DeepCodegen = 1;
envCfg.Quiet = 1;
coder.checkGpuInstall(envCfg);
```

## Pretrained PointPillars Network

Load the pretrained `pointPillarsObjectDetector` trained in the *Lidar 3-D Object Detection Using PointPillars Deep Learning* example. To train the detector yourself, see “Lidar 3-D Object Detection Using PointPillars Deep Learning” on page 1-189.

```
matFile = 'pretrainedPointPillarsDetector.mat';
pretrainedDetector = load('pretrainedPointPillarsDetector.mat','detector');
detector = pretrainedDetector.detector;
```

## pointpillarsDetect Entry-Point Function

The `pointpillarsDetect` entry-point function takes in the point cloud and confidence threshold as input and passes them to a trained `pointPillarsObjectDetector` for prediction through the `pointpillarDetect` function. The `pointpillarsDetect` function loads the detector object from the MAT file into a persistent variable and reuses the persistent object for subsequent prediction calls.

```
type('pointpillarsDetect.m')

function [bboxes,scores,labels] = pointpillarsDetect(matFile,dataLoc,dataInt,threshold)
% Predict the output of network and extract the confidence, x, y,
```

```
% width, height, and class.

% load the deep learning network for prediction
persistent pointPillarObj;

if isempty(pointPillarObj)
    pointPillarObj = coder.loadDeepLearningNetwork(matFile);
end

ptCloud = pointCloud(dataLoc,'Intensity',dataInt);

[bboxes,scores,labels] = pointPillarObj.detect(ptCloud,'Threshold',threshold);
end
```

### **Evaluate the detector for Object Detection**

Read the point cloud.

```
pc = pcread('pandasetDrivingData.pcd');
```

Use the detect method on the pretrained detector.

```
confidenceThreshold = 0.7;
[bboxes,~,labels] = detect(detector,pc,'Threshold',confidenceThreshold);
bboxesCar = bboxes(labels == 'Car',:);
bboxesTruck = bboxes(labels == 'Truck',:);
```

Display the detections on the point cloud.

```
helperDisplay3DBoxesOverlaidPointCloud(pc.Location,bboxesCar,'green',...
    bboxesTruck,'magenta','Predicted bounding boxes');
```

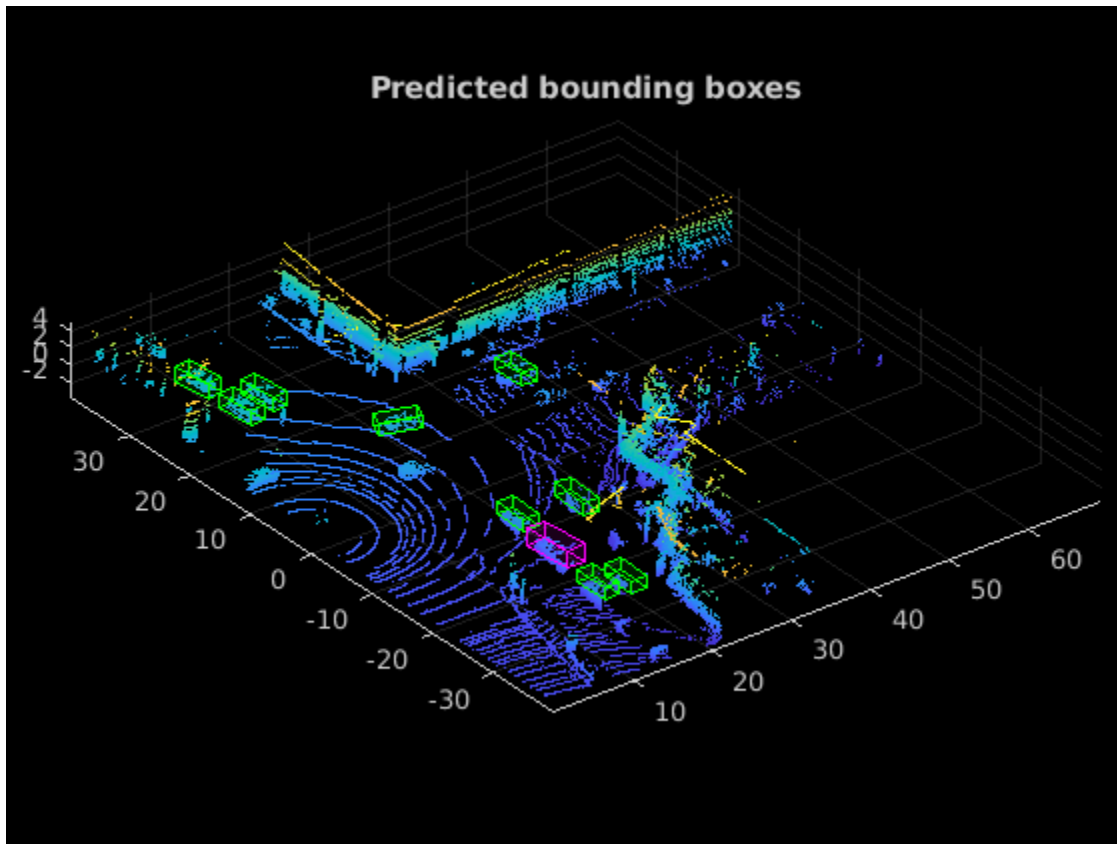

### Generate CUDA MEXscatter

To generate CUDA® code for the `pointpillarsDetect` entry-point function, create a GPU code configuration object for a MEX target and set the target language to C++. Use the `coder.DeepLearningConfig` (GPU Coder) function to create a cuDNN deep learning configuration object and assign it to the `DeepLearningConfig` property of the GPU code configuration object.

```
cfg = coder.gpuConfig('mex');
cfg.TargetLang = 'C++';
cfg.DeepLearningConfig = coder.DeepLearningConfig(TargetLibrary='cudnn');

dataLoc = pc.Location;
dataInt = pc.Intensity;

args = {coder.Constant(matFile) coder.typeof(dataLoc,[Inf,3],[1 0]) coder.typeof(dataInt,[Inf,1])};

codegen -config cfg pointpillarsDetect -args args -report
```

Code generation successful: [View report](#)

### Run the Generated MEX

Call the generated CUDA MEX with the point cloud. Display the results.

```
[bboxes,~,labels] = pointpillarsDetect_mex(matFile,dataLoc,dataInt,confidenceThreshold);
bboxesCar = bboxes(labels == 'Car',:);
bboxesTruck = bboxes(labels == 'Truck',:);
```

```
helperDisplay3DBoxesOverlaidPointCloud(pc.Location,bboxesCar,'green',...
    bboxesTruck,'magenta','Predicted bounding boxes');
```

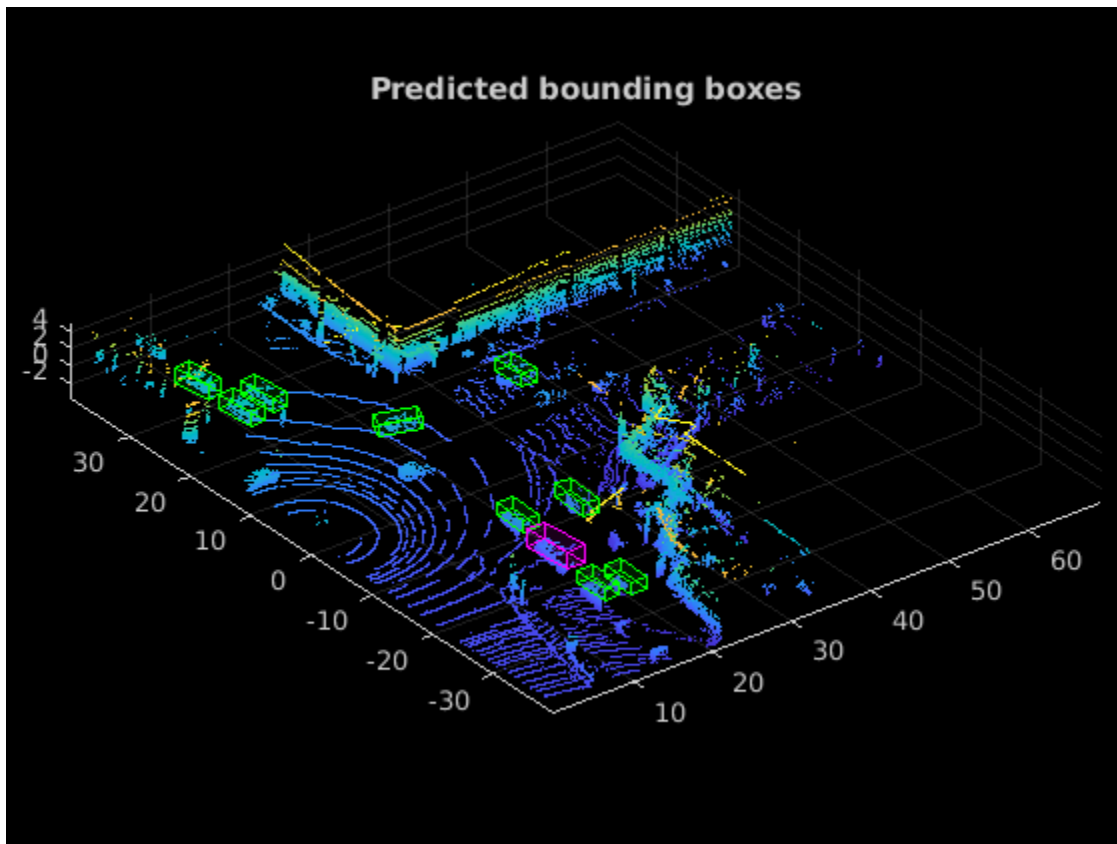

### Helper Functions

```
function helperDisplay3DBoxesOverlaidPointCloud(ptCld,labelsCar,carColor,...
    labelsTruck,truckColor,titleForFigure)
% Display the point cloud with different colored bounding boxes for different
% classes
figure;
ax = pcshow(ptCld);
showShape('cuboid',labelsCar,'Parent',ax,'Opacity',0.1,'Color',...
    carColor,'LineWidth',0.5);
hold on;
showShape('cuboid',labelsTruck,'Parent',ax,'Opacity',0.1,'Color',...
    truckColor,'LineWidth',0.5);
title(titleForFigure);
zoom(ax,1.5);
end
```

### References

[1] Lang, Alex H., Sourabh Vora, Holger Caesar, Lubing Zhou, Jiong Yang, and Oscar Beijbom. "PointPillars: Fast Encoders for Object Detection From Point Clouds." *In 2019 IEEE/CVF Conference on Computer Vision and Pattern Recognition (CVPR)*, 12689-12697. Long Beach, CA, USA: IEEE, 2019. <https://doi.org/10.1109/CVPR.2019.01298>.

[2] Hesai and Scale. PandaSet. <https://scale.com/open-datasets/pandaset>.

## Aerial Lidar Semantic Segmentation Using PointNet++ Deep Learning

This example shows how to train a PointNet++ deep learning network to perform semantic segmentation on aerial lidar data.

Lidar data acquired from airborne laser scanning systems is used in applications such as topographic mapping, city modeling, biomass measurement, and disaster management. Extracting meaningful information from this data requires semantic segmentation, a process where each point in the point cloud is assigned a unique class label.

In this example, you train a PointNet++ network to perform semantic segmentation by using the Dayton Annotated Lidar Earth Scan (DALES) dataset [1 on page 1-0 ]. The dataset contains scenes of dense, labeled aerial lidar data from urban, suburban, rural, and commercial settings. The dataset provides semantic segmentation labels for 8 classes such as buildings, cars, trucks, poles, power lines, fences, ground, and vegetation.

### Load DALES Data

The DALES dataset contains 40 scenes of aerial lidar data. Out of the 40 scenes, 29 scenes are used for training and the remaining 11 scenes are used for testing. Each pixel in the data has a class label. Follow the instructions on the DALES website to download the dataset to the folder specified by the `dataFolder` variable. Create folders to store training and test data.

```
dataFolder = fullfile(tempdir, 'DALES');  
trainDataFolder = fullfile(dataFolder, 'dales_las', 'train');  
testDataFolder = fullfile(dataFolder, 'dales_las', 'test');
```

Preview a point cloud from the training data.

```
lasReader = lasFileReader(fullfile(trainDataFolder, '5080_54435.las'));  
[pc,attr] = readPointCloud(lasReader, 'Attributes', 'Classification');  
labels = attr.Classification;
```

```
% Select only labeled data.  
pc = select(pc, labels~=0);  
labels = labels(labels~=0);  
classNames = [  
    "ground"  
    "vegetation"  
    "cars"  
    "trucks"  
    "powerlines"  
    "fences"  
    "poles"  
    "buildings"  
];  
figure;  
ax = pcshow(pc.Location, labels);  
helperLabelColorbar(ax, classNames);  
title("Point Cloud with Overlaid Semantic Labels");
```

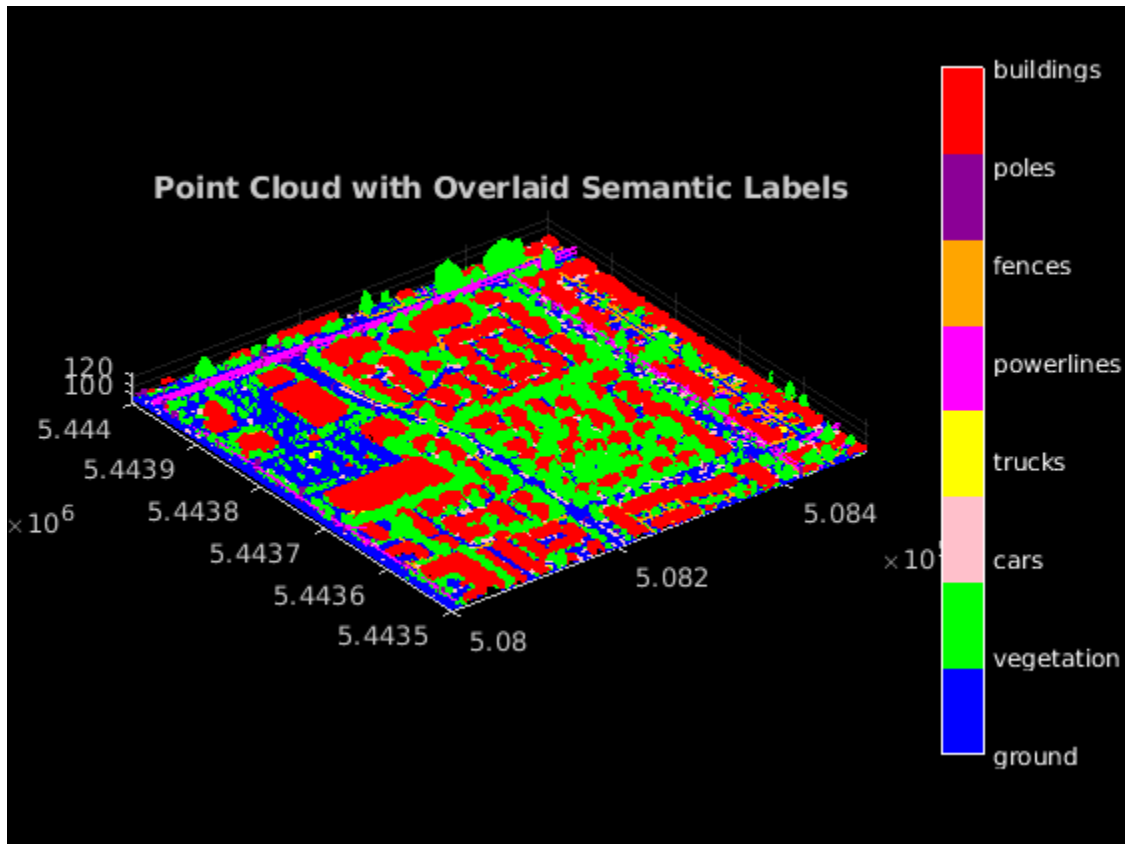

### Preprocess Data

Each point cloud in the DALES dataset covers an area of 500-by-500 meters, which is much larger than the typical area covered by terrestrial lidar point clouds. For efficient memory processing, divide the point cloud into small, non-overlapping blocks by using a `blockedPointCloud` object.

Define the block dimensions using the `blockSize` parameter. As the size of each point cloud in the dataset varies, set the z-dimension of the block to `Inf` to avoid block creation along z-axis.

```
blocksize = [51 51 Inf];
```

Create a `matlab.io.datastore.FileSet` object to collect all the point cloud files in the training data.

```
fs = matlab.io.datastore.FileSet(trainDataFolder);
```

Create a `blockedPointCloud` object using the `FileSet` object.

```
bpc = blockedPointCloud(fs,blocksize);
```

Note: Processing can take some time. The code suspends MATLAB® execution until processing is complete.

Use the `helperCalculateClassWeights` helper function, attached to this example as a supporting file, to calculate the point distribution across all the classes in the training dataset.

```
numClasses = numel(classNames);
[weights,maxLabel,maxWeight] = helperCalculateClassWeights(fs,numClasses);
```

### Create Datastore Object for Training

Create a `blockedPointCloudDatastore` object using the blocked point cloud, `bpc` to train the network.

```
ldsTrain = blockedPointCloudDatastore(bpc);
```

Specify label IDs from 1 to the number of classes.

```
labelIDs = 1 : numClasses;
```

Preview and display the point cloud.

```
ptcld = preview(ldsTrain);
figure;
pcshow(ptcld.Location);
title("Cropped Point Cloud");
```

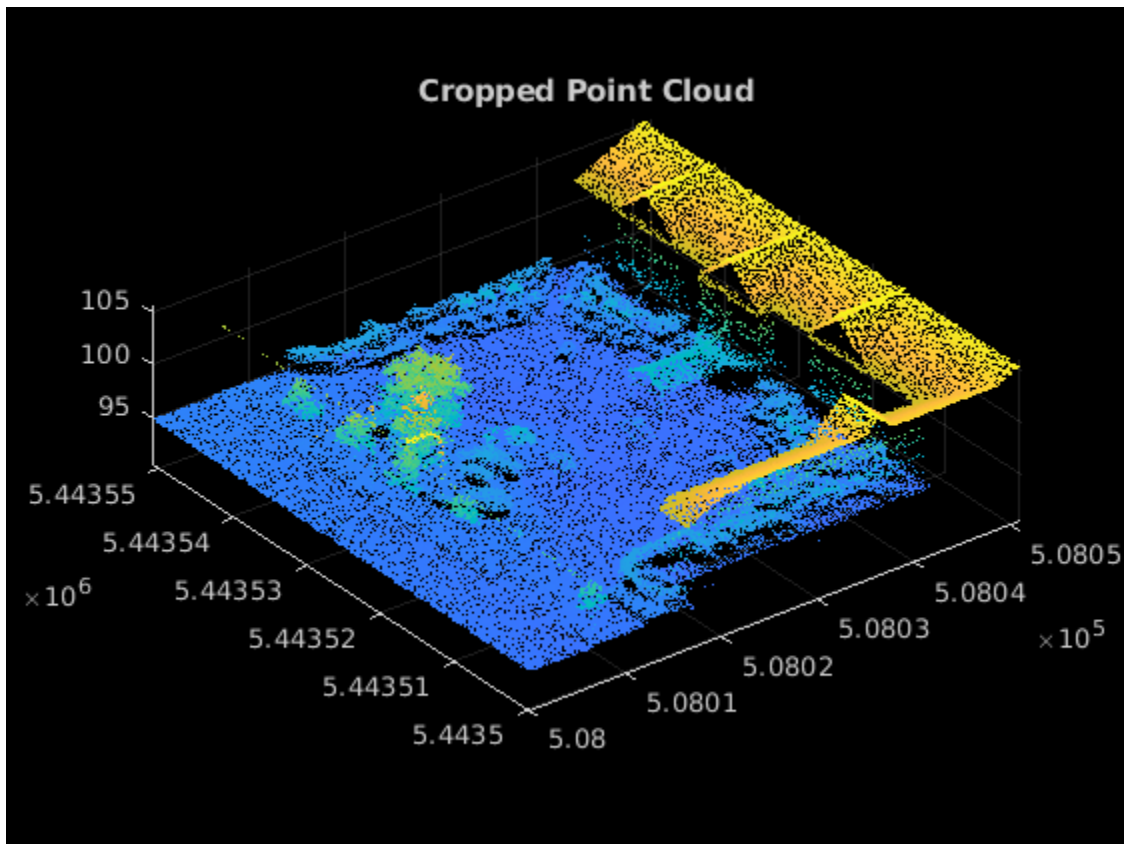

For faster training, set a fixed number of points per block.

```
numPoints = 8192;
```

Transform the data to make it compatible with the input layer of the network, using the `helperTransformToTrainData` function, defined at the end of this example. Follow these steps to apply transformation.

- Extract the point cloud and the respective labels.



- Downsample the point cloud, the labels to a specified number, numPoints.
- Normalize the point clouds to the range [0 1].
- Convert the point cloud and the corresponding labels to make them compatible with the input layer of the network.

```
ldsTransformed = transform(ldsTrain,@(x,info) helperTransformToTrainData(x, ...
    numPoints,info,labelIDs,classNames),'IncludeInfo',true);
read(ldsTransformed)
```

```
ans=1x2 cell array
    {8192x1x3 double}    {8192x1 categorical}
```

### Define PointNet++ Model

PointNet++ is a popular neural network used for semantic segmentation of unorganized lidar point clouds. Semantic segmentation associates each point in a 3-D point cloud with a class label, such as car, truck, ground, or vegetation. For more information, see “Getting Started with PointNet++” on page 4-52.

Define the PointNet++ architecture using the `pointnetplusLayers` function.

```
lgraph = pointnetplusLayers(numPoints,3,numClasses);
```

To handle the class-imbalance on the DALES dataset, the weighted cross-entropy loss from the `pixelClassificationLayer` function is used. This will penalize the network more if a point that belongs to a class with lower weight is misclassified.

```
% Replace the FocalLoss layer with pixelClassificationLayer.
larray = pixelClassificationLayer('Name','SegmentationLayer','ClassWeights', ...
    weights,'Classes',classNames);
lgraph = replaceLayer(lgraph,'FocalLoss',larray);
```

### Specify Training Options

Use the Adam optimization algorithm to train the network. Use the `trainingOptions` (Deep Learning Toolbox) function to specify the hyperparameters.

```
learningRate = 0.0005;
l2Regularization = 0.01;
numEpochs = 20;
miniBatchSize = 16;
learnRateDropFactor = 0.1;
learnRateDropPeriod = 10;
gradientDecayFactor = 0.9;
squaredGradientDecayFactor = 0.999;

options = trainingOptions('adam', ...
    'InitialLearnRate',learningRate, ...
    'L2Regularization',l2Regularization, ...
    'MaxEpochs',numEpochs, ...
    'MiniBatchSize',miniBatchSize, ...
    'LearnRateSchedule','piecewise', ...
    'LearnRateDropFactor',learnRateDropFactor, ...
    'LearnRateDropPeriod',learnRateDropPeriod, ...
    'GradientDecayFactor',gradientDecayFactor, ...
    'SquaredGradientDecayFactor',squaredGradientDecayFactor, ...
```

```
'Plots','training-progress', ...  
'ExecutionEnvironment','gpu');
```

Note: Reduce the `miniBatchSize` value to control memory usage when training.

### Train Model

To train the network, set the `doTraining` argument to `true`. Otherwise, load a pretrained network. To train the network, you can use CPU or GPU. Using a GPU requires Parallel Computing Toolbox™ and a CUDA® enabled NVIDIA® GPU. For more information, see “GPU Support by Release” (Parallel Computing Toolbox).

```
doTraining = false;  
if doTraining  
    % Train the network on the ldsTransformed datastore using  
    % the trainNetwork function.  
    [net,info] = trainNetwork(ldsTransformed,lgraph,options);  
else  
    % Load the pretrained network.  
    load('pointnetplusTrained','net');  
end
```

### Segment Aerial Point Cloud

To perform segmentation on the test point cloud, first create a `blockedPointCloud` object, then create a `blockedPointCloudDatastore` object.

Apply the similar transformation used on training data, to the test data:

- Extract the point cloud and the respective labels.
- Downsample the point cloud, and the labels to a specified number, `numPoints`.
- Normalize the point clouds to the range [0 1].
- Convert the point cloud to make it compatible with the input layer of the network.

```
tbpc = blockedPointCloud(fullfile(testDataFolder,'5080_54470.las'),blocksize);  
tbpcds = blockedPointCloudDatastore(tbpc);
```

Define `numNearestNeighbors` and `radius` to find the nearest points in the downsampled point cloud for each point in the dense point cloud and to perform interpolation effectively.

```
numNearestNeighbors = 20;  
radius = 0.05;
```

Initialize the placeholders for the predicted and target labels.

```
labelsDensePred = [];  
labelsDenseTarget = [];
```

Perform inference on this test point cloud to compute prediction labels. Interpolate the prediction labels, to obtain prediction labels on the dense point cloud. Iterate the process all over the non-overlapping blocks and predict the labels using the `semanticseg` function.

```
while hasdata(tbpcds)  
    % Read the block along with block information.  
    [ptCloudDense,infoDense] = read(tbpcds);
```

```

% Extract the labels from the block information.
labelsDense = infoDense.PointAttributes.Classification;

% Select only labeled data.
ptCloudDense = select(ptCloudDense{1},labelsDense~=0);
labelsDense = labelsDense(labelsDense~=0);

% Use the helperDownsamplePoints function, attached to this example as a
% supporting file, to extract a downsampled point cloud from the
% dense point cloud.
ptCloudSparse = helperDownsamplePoints(ptCloudDense, ...
    labelsDense,numPoints);

% Make the spatial extent of the dense point cloud and the sparse point
% cloud same.
limits = [ptCloudDense.XLimits;ptCloudDense.YLimits;ptCloudDense.ZLimits];
ptCloudSparseLocation = ptCloudSparse.Location;
ptCloudSparseLocation(1:2,:) = limits(:,1:2)';
ptCloudSparse = pointCloud(ptCloudSparseLocation,'Color',ptCloudSparse.Color, ...
    'Intensity',ptCloudSparse.Intensity, ...
    'Normal',ptCloudSparse.Normal);

% Use the helperNormalizePointCloud function, attached to this example as
% a supporting file, to normalize the point cloud between 0 and 1.
ptCloudSparseNormalized = helperNormalizePointCloud(ptCloudSparse);
ptCloudDenseNormalized = helperNormalizePointCloud(ptCloudDense);

% Use the helperTransformToTestData function, defined at the end of this
% example, to convert the point cloud to a cell array and to permute the
% dimensions of the point cloud to make it compatible with the input layer
% of the network.
ptCloudSparseForPrediction = helperTransformToTestData(ptCloudSparseNormalized);

% Get the output predictions.
labelsSparsePred = semanticseg(ptCloudSparseForPrediction{1,1}, ...
    net,'OutputType','uint8');

% Use the helperInterpolate function, attached to this example as a
% supporting file, to calculate labels for the dense point cloud,
% using the sparse point cloud and labels predicted on the sparse point cloud.
interpolatedLabels = helperInterpolate(ptCloudDenseNormalized, ...
    ptCloudSparseNormalized,labelsSparsePred,numNearestNeighbors, ...
    radius,maxLabel,numClasses);

% Concatenate the predicted and target labels from the blocks.
labelsDensePred = vertcat(labelsDensePred,interpolatedLabels);
labelsDenseTarget = vertcat(labelsDenseTarget,labelsDense);
end

```

Starting parallel pool (parpool) using the 'local' profile ...  
Connected to the parallel pool (number of workers: 6).

For better visualisation, only display a block inferred from the point cloud data.

```

figure;
ax = pcshow(ptCloudDense.Location,interpolatedLabels);
axis off;

```

```
helperLabelColorbar(ax,classNames);
title("Point Cloud Overlaid with Detected Semantic Labels");
```

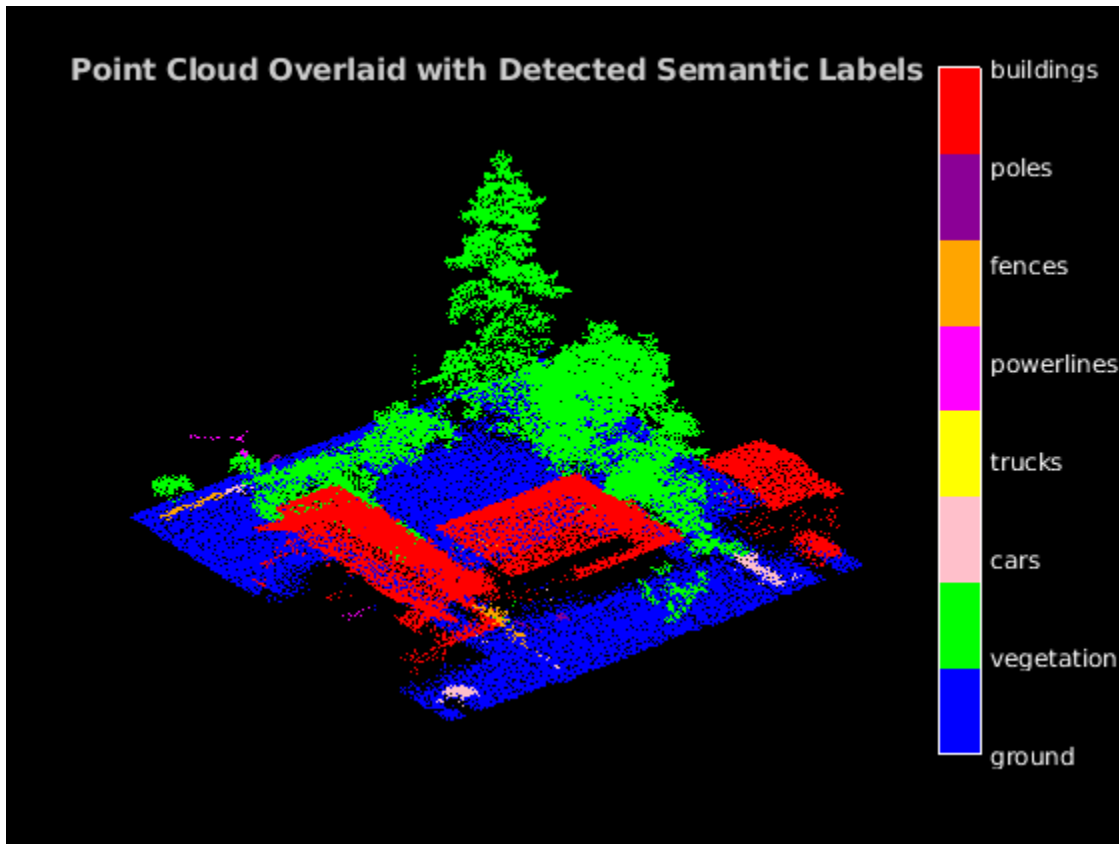

### Evaluate Network

Evaluate the network performance on the test data. Use the `evaluateSemanticSegmentation` function to compute the semantic segmentation metrics from the test set results. The target and predicted labels are computed previously and are stored in the `labelsDensePred` and the `labelsDenseTarget` variables respectively.

```
confusionMatrix = segmentationConfusionMatrix(double(labelsDensePred), ...
    double(labelsDenseTarget), 'Classes', 1:numClasses);
metrics = evaluateSemanticSegmentation({confusionMatrix}, classNames, 'Verbose', false);
```

You can measure the amount of overlap per class using the intersection-over-union (IoU) metric.

The `evaluateSemanticSegmentation` function returns metrics for the entire data set, for individual classes, and for each test image. To see the metrics at the data set level, use the `metrics.DataSetMetrics` property.

```
metrics.DataSetMetrics
```

```
ans=1x4 table
```

GlobalAccuracy	MeanAccuracy	MeanIoU	WeightedIoU
0.93104	0.65003	0.52971	0.87937

The data set metrics provide a high-level overview of network performance. To see the impact each class has on the overall performance, inspect the metrics for each class using the `metrics.ClassMetrics` property.

```
metrics.ClassMetrics
```

```
ans=8x2 table
```

	Accuracy	IoU
ground	0.98381	0.93339
vegetation	0.86131	0.81124
cars	0.67507	0.38561
trucks	0.012988	0.0094479
powerlines	0.76932	0.70852
fences	0.39146	0.23877
poles	0.57564	0.25588
buildings	0.93064	0.89481

Although the overall network performance is good, the class metrics for some classes like Trucks indicate that more training data is required for better performance.

### Supporting Functions

The `helperLabelColorbar` function adds a colorbar to the current axis. The colorbar is formatted to display the class names with the color.

```
function helperLabelColorbar(ax,classNames)
% Colormap for the original classes.
cmap = [[0 0 255];
        [0 255 0];
        [255 192 203];
        [255 255 0];
        [255 0 255];
        [255 165 0];
        [139 0 150];
        [255 0 0]];
cmap = cmap./255;
cmap = cmap(1:numel(classNames),:);
colormap(ax,cmap);

% Add colorbar to current figure.
c = colorbar(ax);
c.Color = 'w';

% Center tick labels and use class names for tick marks.
numClasses = size(classNames,1);
c.Ticks = 1:1:numClasses;
c.TickLabels = classNames;

% Remove tick mark.
c.TickLength = 0;
end
```

The `helperTransformToTrainData` function performs these set of transforms on the input data which are:

- Extract the point cloud and the respective labels.
- Downsample the point cloud, the labels to a specified number, numPoints.
- Normalize the point clouds to the range [0 1].
- Convert the point cloud and the corresponding labels to make them compatible with the input layer of the network.

```
function [cellout,dataout] = helperTransformToTrainData(data,numPoints,info,...
    labelIDs,classNames)
if ~iscell(data)
    data = {data};
end
numObservations = size(data,1);
cellout = cell(numObservations,2);
dataout = cell(numObservations,2);
for i = 1:numObservations
    classification = info.PointAttributes(i).Classification;

    % Use the helperDownsamplePoints function, attached to this example as a
    % supporting file, to extract a downsampled point cloud and its labels
    % from the dense point cloud.
    [ptCloudOut,labelsOut] = helperDownsamplePoints(data{i,1}, ...
        classification,numPoints);

    % Make the spatial extent of the dense point cloud and the sparse point
    % cloud same.
    limits = [ptCloudOut.XLimits;ptCloudOut.YLimits;...
        ptCloudOut.ZLimits];
    ptCloudSparseLocation = ptCloudOut.Location;
    ptCloudSparseLocation(1:2,:) = limits(:,1:2)';
    ptCloudSparseUpdated = pointCloud(ptCloudSparseLocation, ...
        'Intensity',ptCloudOut.Intensity, ...
        'Color',ptCloudOut.Color, ...
        'Normal',ptCloudOut.Normal);

    % Use the helperNormalizePointCloud function, attached to this example as
    % a supporting file, to normalize the point cloud between 0 and 1.
    ptCloudOutSparse = helperNormalizePointCloud( ...
        ptCloudSparseUpdated);

    tmp = ptCloudOutSparse.Location;

    % Permuted output.
    cellout{i,1} = permute(tmp,[1 3 2]);
    cellout{i,2} = permute(categorical(labelsOut,labelIDs,classNames),[1 3 2]);

    % General output.
    dataout{i,1} = ptCloudOutSparse;
    dataout{i,2} = labelsOut;
end
end
```

The helperTransformToTestData function converts the point cloud to a cell array and permutes the dimensions of the point cloud to make it compatible with the input layer of the network.

```
function data = helperTransformToTestData(data)
if ~iscell(data)
    data = {data};
```

```
end
numObservations = size(data,1);
for i = 1:numObservations
    tmp = data{i,1}.Location;
    data{i,1} = permute(tmp,[1 3 2]);
end
end
```

## References

- [1] Varney, Nina, Vijayan K. Asari, and Quinn Graehling. "DALES: A Large-Scale Aerial LiDAR dataset for Semantic Segmentation." *ArXiv:2004.11985 [Cs, Stat]*, April 14, 2020. <https://arxiv.org/abs/2004.11985>.
- [2] Qi, Charles R., Li Yi, Hao Su, and Leonidas J. Guibas. "PointNet++: Deep Hierarchical Feature Learning on Point Sets in a Metric Space." *ArXiv:1706.02413 [Cs]*, June 7, 2017. <https://arxiv.org/abs/1706.02413>.





# Lidar Labeling

---

- “Get Started with the Lidar Labeler” on page 2-2
- “Keyboard Shortcuts and Mouse Actions for Lidar Labeler” on page 2-12
- “Use Custom Point Cloud Source Reader for Labeling” on page 2-15
- “Create Automation Algorithm for Labeling” on page 2-17
- “Temporal Automation Algorithms” on page 2-21

## Get Started with the Lidar Labeler

The **Lidar Labeler** app enables you to interactively label ground truth data in a point cloud or a point cloud sequence and generate corresponding ground truth data.

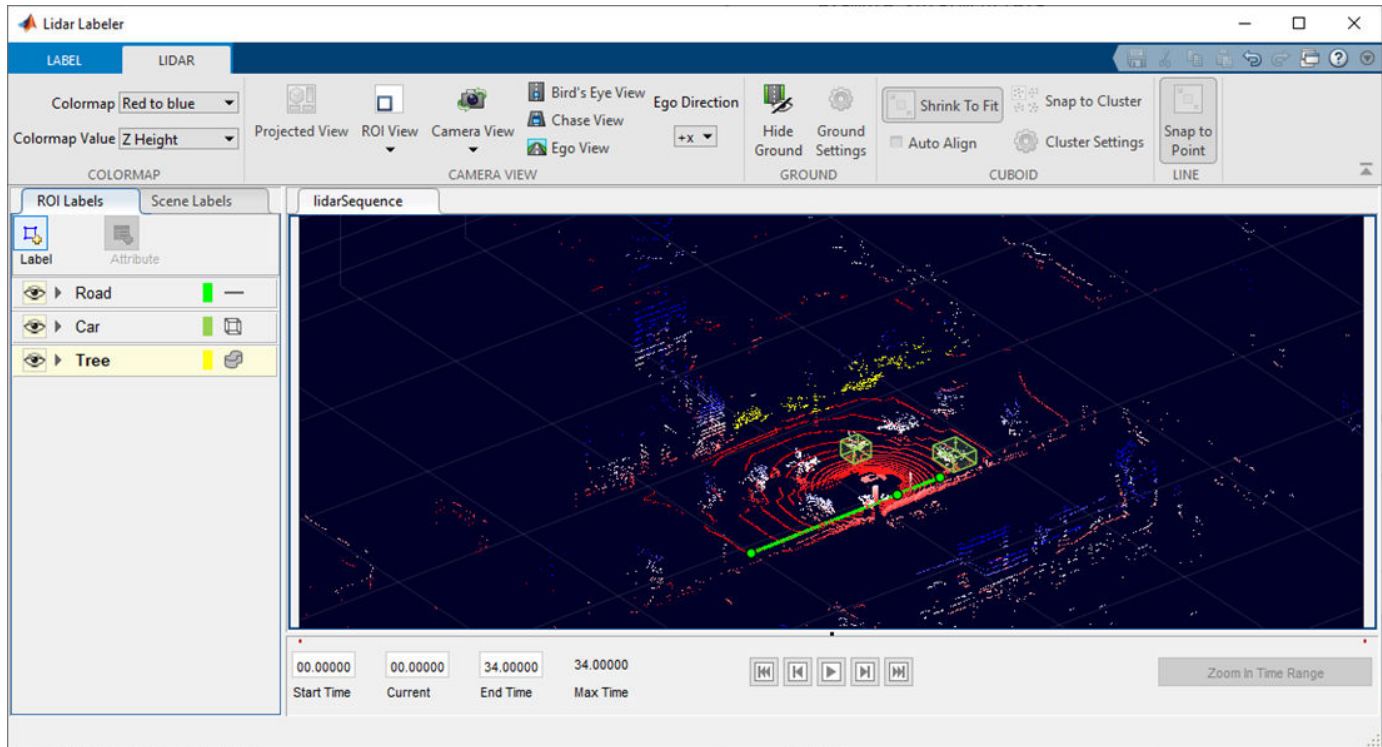

This example demonstrates the capabilities of the **Lidar Labeler** app in a lidar ground truth data labeling workflow.

### Load Lidar Data to Label

Use the **Lidar Labeler** app to interactively label point cloud files and sequences of point cloud files.

#### Open Lidar Labeler App

To open the **Lidar Labeler** app, at the MATLAB® command prompt, enter this command.

```
lidarLabeler
```

The app opens to an empty session.

Alternatively, you can open the app from the **Apps** tab, under **Image Processing and Computer Vision**.

#### Load Signals from Data Sources

The **Lidar Labeler** app enables you to load signals from multiple types of data sources. In the app, a data source is a file or folder containing one or more signals to label. Use this process to load the data for a point cloud sequence.

- 1 On the app toolstrip, click **Import > Add Point Cloud**. The **Select Point Cloud** window opens with the **Source Type** parameter already set to Point Cloud Sequence.

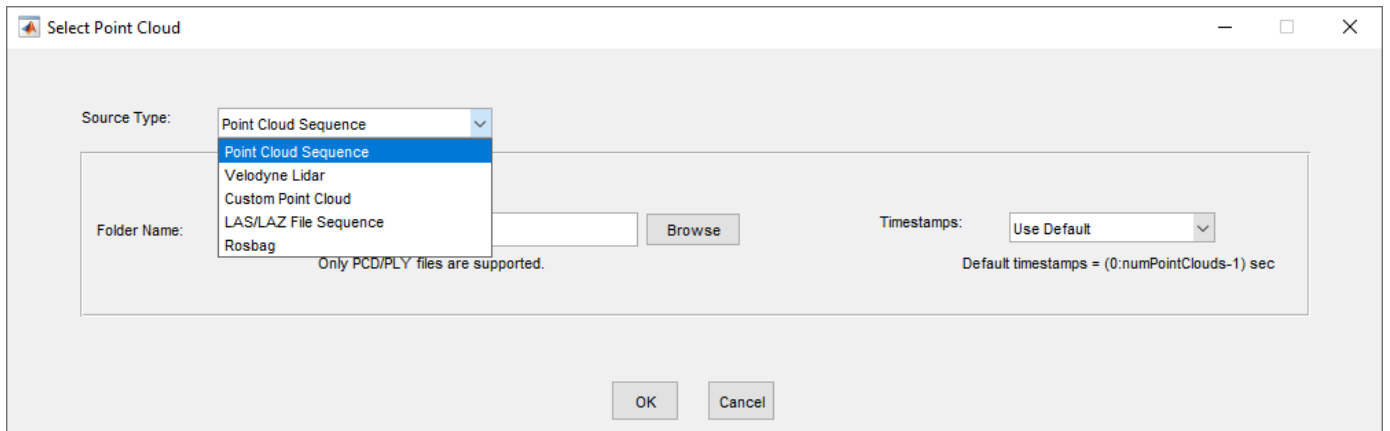

- 2 In the **Folder Name** parameter, browse to the folder that contains the sequence of point cloud data(PCD) files that you want to load and click **Select Folder**.
- 3 If you have a variable of timestamps in the MATLAB workspace, set the **Timestamps** parameter to From Workspace and, in the Import From Workspace window, select the variable and click **OK**. Otherwise, set it to Use Default.

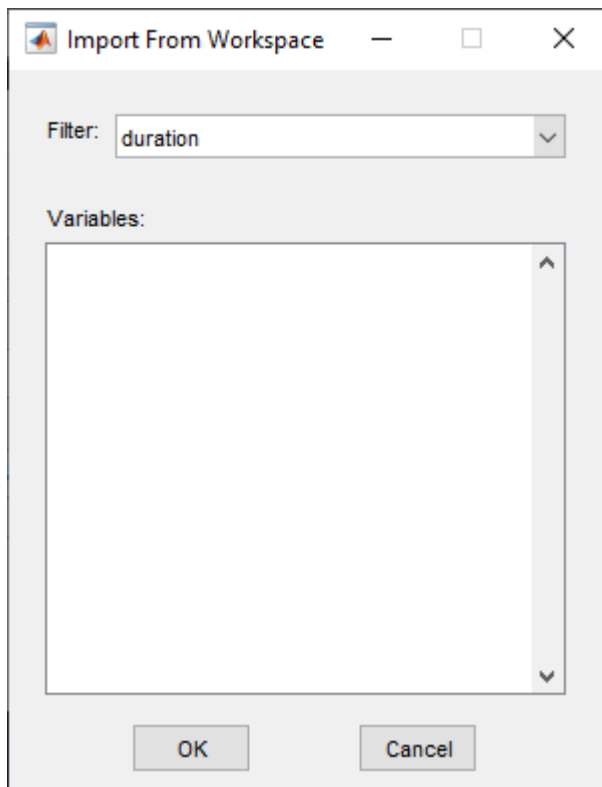

- 4 In the **Select Point Cloud** window, click **OK**. The point cloud sequence loads into the app.

## Create Labels and Attributes

After loading the point cloud data into the **Lidar Labeler** app, create label definitions and attributes. Label definitions contain the information about the labels that you wish to annotate the points with. You can create label definitions interactively within the app or programmatically by using a `LabelDefinitionCreatorLidar` object.

### Create an ROI Label Definition

An *ROI label* is a label that corresponds to a region of interest (ROI).

- 1 On the **ROI Labels** tab in the left pane, click **Label**.
- 2 You can create Cuboid, Line, Voxel label types and provide names for the labels.

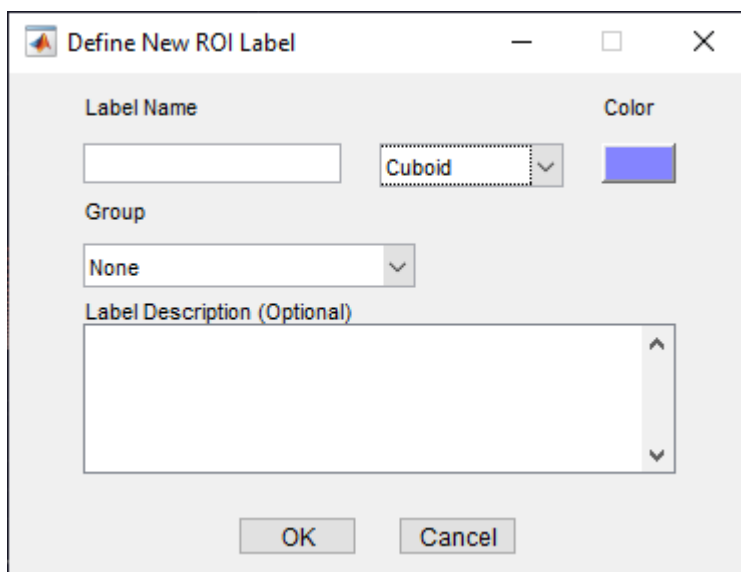

- 3 From the Group list, select New Group and provide a name for the group. Adding labels to groups is optional.
- 4 The specified group name appears on the **ROI Labels** tab with the specified label name under it.

For more details about these labels, see “ROI Labels and Attributes”.

### Create an ROI Attribute

An ROI attribute specifies additional information about an ROI label. You can define ROI attributes of these types.

- **Numeric Value** — Specify a numeric scalar attribute, such as the number of doors on a labeled vehicle.
- **String** — Specify a string scalar attribute, such as the color of a vehicle.
- **Logical** — Specify a logical true or false attribute, such as whether a vehicle is in motion.
- **List** — Specify a drop-down list attribute of predefined strings, such as make or model of a vehicle.

Use this process to create an attribute.

- 1 On the **ROI Labels** tab in the left pane, select a label and click **Attribute**.
- 2 Provide a name in the **Attribute Name** box. Select the attribute type and optionally give the attribute a description, and click **OK**. You can hover over the information icon that appears next to the attribute field to display the added description.

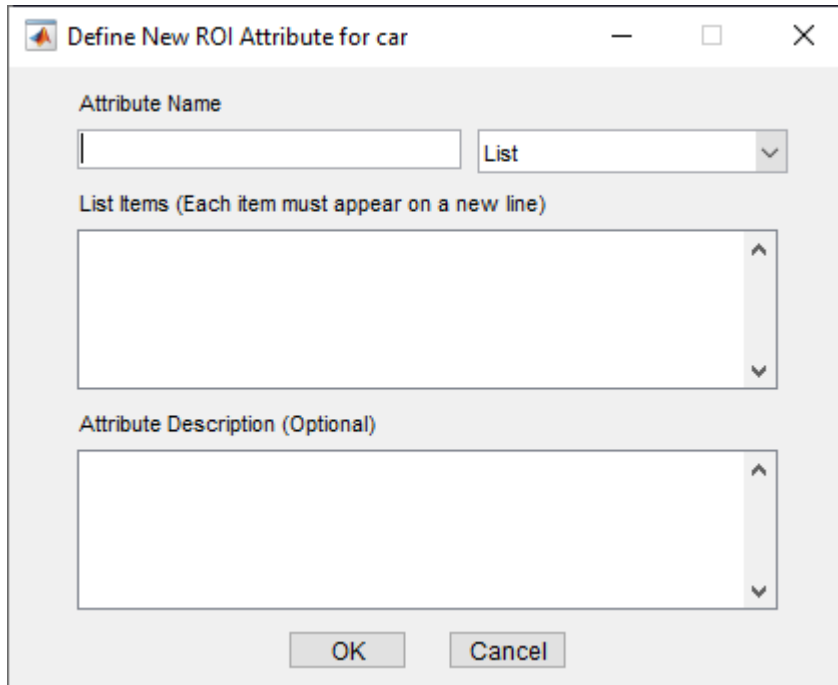

The screenshot shows a dialog box titled "Define New ROI Attribute for car". It features a standard window title bar with minimize, maximize, and close buttons. The dialog is divided into three sections: "Attribute Name" with a text input field and a dropdown menu set to "List"; "List Items (Each item must appear on a new line)" with a large text area and a vertical scrollbar; and "Attribute Description (Optional)" with another large text area and a vertical scrollbar. At the bottom, there are "OK" and "Cancel" buttons.

For more details about these attributes, see “ROI Labels and Attributes”.

### Create a Scene Label Definition

A scene label defines additional information across a scene. Use scene labels to describe conditions, such as lighting and weather, or events, such as lane changes.

Use this process to create a scene label definition.

- 1 Select the **Scene Labels** tab in the left pane of the app and click **Define new scene label**.
- 2 In the Define new scene label window provide a name for the label.
- 3 Choose a **Color** for the label.

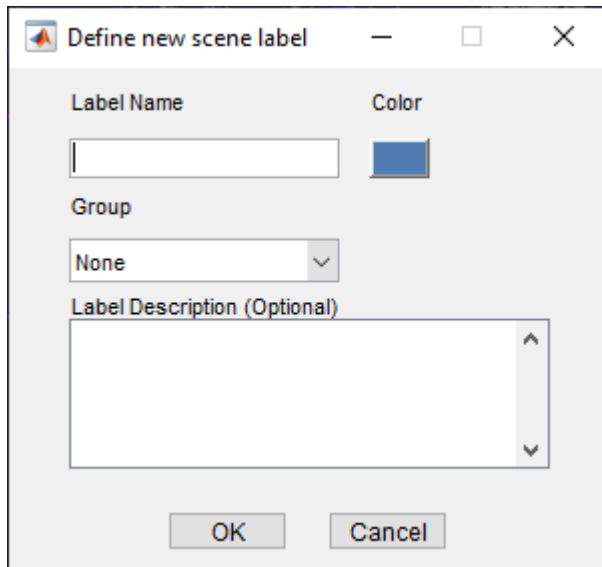

- 4 From the Group list, select **New Group** and provide a name for the group. Adding labels to groups is optional.
- 5 The **Scene Labels** pane shows the scene label definition.

## Ground Segmentation

The **Lidar Labeler** app provides ground segmentation feature to hide ground points in the point cloud. Ground removal makes it easier to find objects during labeling. Use this process to hide ground points:

- 1 In the **Lidar** tab, select **Hide Ground** to segment and hide the ground points. This also enables the **Ground Settings** button.
- 2 Select **Ground Settings** to change the ground segmentation algorithm and tune the corresponding parameters.

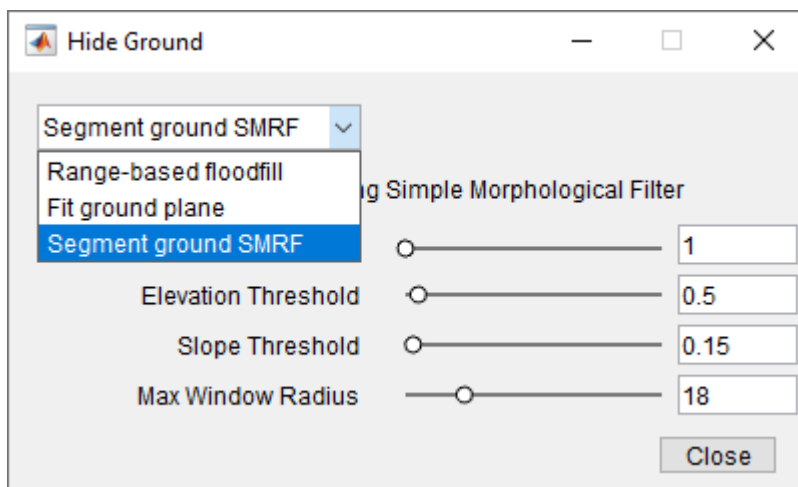

- 3 Select a segmentation algorithm from the drop-down. The app supports these algorithms:

- Range-based floodfill (default) — Segment the ground plane in organized point cloud data using the `segmentGroundFromLidarData` function.
  - Fit ground plane — Segment the ground plane in organized point cloud data using the `pcfitplane` function.
  - Segment ground SMRF — Segment the ground plane in both organized and unorganized point clouds using the `segmentGroundSMRF` function. Use this algorithm for non-uniform ground planes and aerial lidar data. The default parameters are tuned for aerial data. For ground lidar data, decrease the **Max Window Radius** parameter to 5 and the **Elevation Threshold** parameter to a value in the range [0.2, 0.3].
- 4 After selecting an algorithm, the dialog box displays the corresponding parameters. You can adjust the parameters using the sliders to improve segmentation results.

## Label Point Cloud Using Automation

You can use an automation algorithm to automatically label your data by using one of the included algorithms or by creating and importing a custom automation algorithm. For more details on creating a custom automation algorithm, see “Create Automation Algorithm for Labeling” on page 2-17. The app includes the **Lidar Object Tracker** and **Point Cloud Temporal Interpolator** labeling automation algorithms.

Use this process to label point cloud data using an automation algorithm.

- 1 Load the data into the app and create a ROI label definition.
- 2 On the **LABEL** tab of the app toolbar, in the **Automate Labeling** section, click **Select Algorithm**.

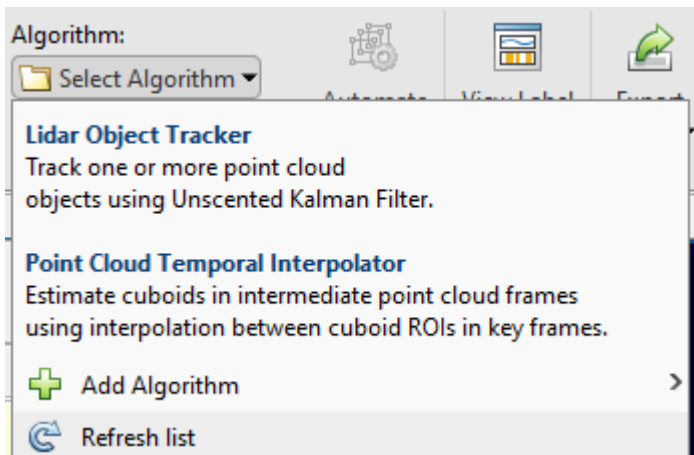

- 3 Select an algorithm for automation.
- 4 Click **Automate** and then follow the automation instructions in the right pane of the app.

## View and Adjust the Labels

Once you have created labels for your point cloud data, the app provides options for viewing, adjusting, and comparing your point cloud and label data.

## Projected View

On the **LIDAR** tab of the app toolbar, click **Projected View** to view the selected label in front-view, top-view, and side-view simultaneously. Use these views to manually adjust the accuracy of your labels.

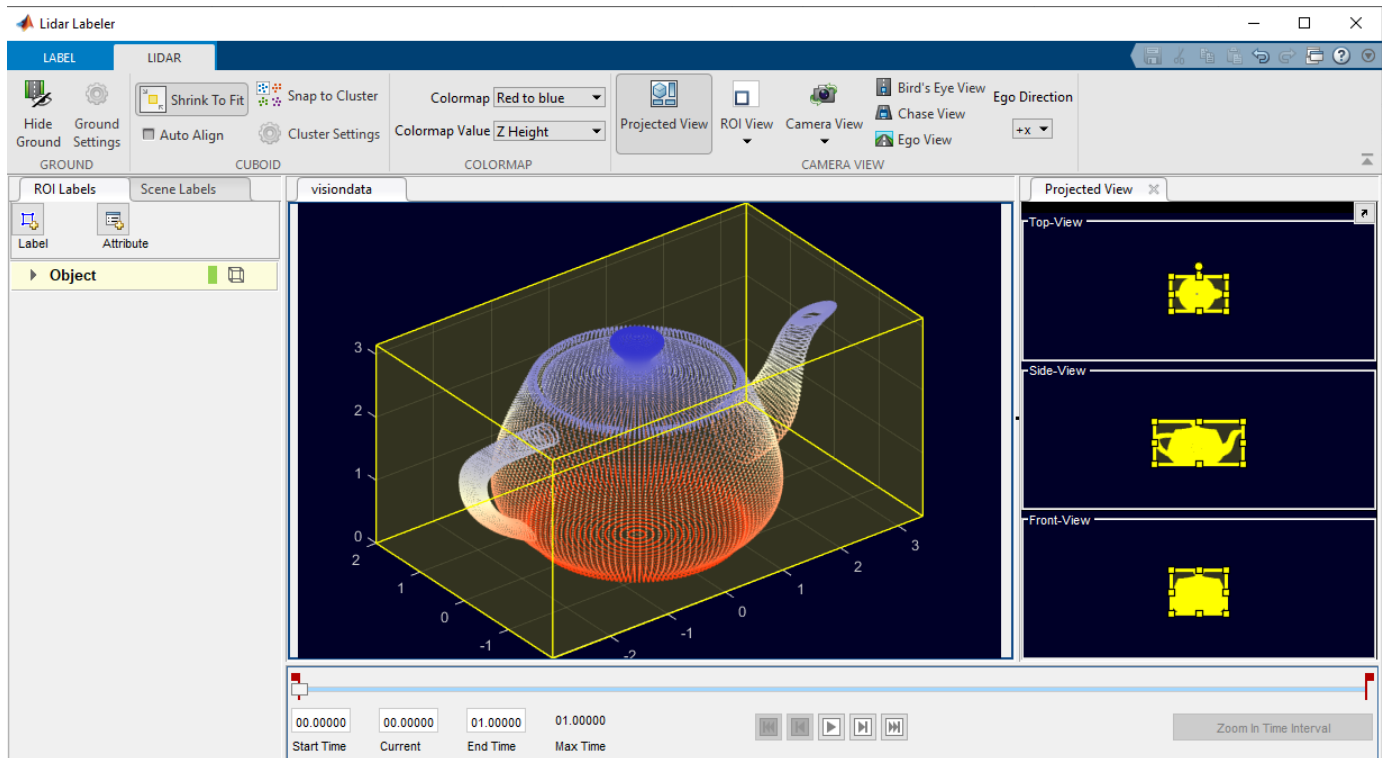

Enable the **Auto Align** option to fit the cuboid to the label data and align the label in the direction of the object. This image shows the difference in a label with and without the **Auto Align** option enabled.

Label without <b>Auto Align</b> option	Label with <b>Auto Align</b> option

## Camera View

Use the **Camera View** option to save and reuse custom views of the point cloud data. You can rotate, pan, and zoom the view, then save the view by clicking **Camera View** and selecting **Save Camera View**. Specify a name for the view and click **OK**. You can return to the saved view at any time by clicking **Camera View** and selecting the saved view from the drop-down list.

## ROI View

You can define and view a region of interest (ROI) in the point cloud using the **ROI View**, and then select **Select ROI**.

The app opens the **Adjust ROI Limits** dialog box, which contains the ROI parameters.



To specify  $x$ -,  $y$ -, and  $z$ -axes limits for the ROI, drag the corresponding minimum and maximum value sliders. Alternatively, you can type new minimum or maximum values in the corresponding text boxes. You can also adjust the displayed point size of the point cloud using the **Point Size** parameter. Use this to improve visualizations of sparse point clouds by increasing their point size. If you want to return to the full view of the point cloud, click **ROI View** and select **Full View**.

## Sync Image Viewer

Connect an external tool to the application to display time-synchronized images for use as reference while labeling. See the `lidar.syncImageViewer.SyncImageViewer` class. The following example shows how to connect an external image display to the **Lidar Labeler**.

### Connect Image Display to Lidar Labeler

Connect an image display tool to the **Lidar Labeler** app. Use the app and tool to display synchronized lidar and image data.

Specify the name of the lidar data to load into the app.

```
sourceName = fullfile('lidarSequence');
```

Connect the video display to the app and display synchronized data.

```
lidarLabeler(sourceName, 'SyncImageViewerTargetHandle', @helperSyncImageDisplay);
```

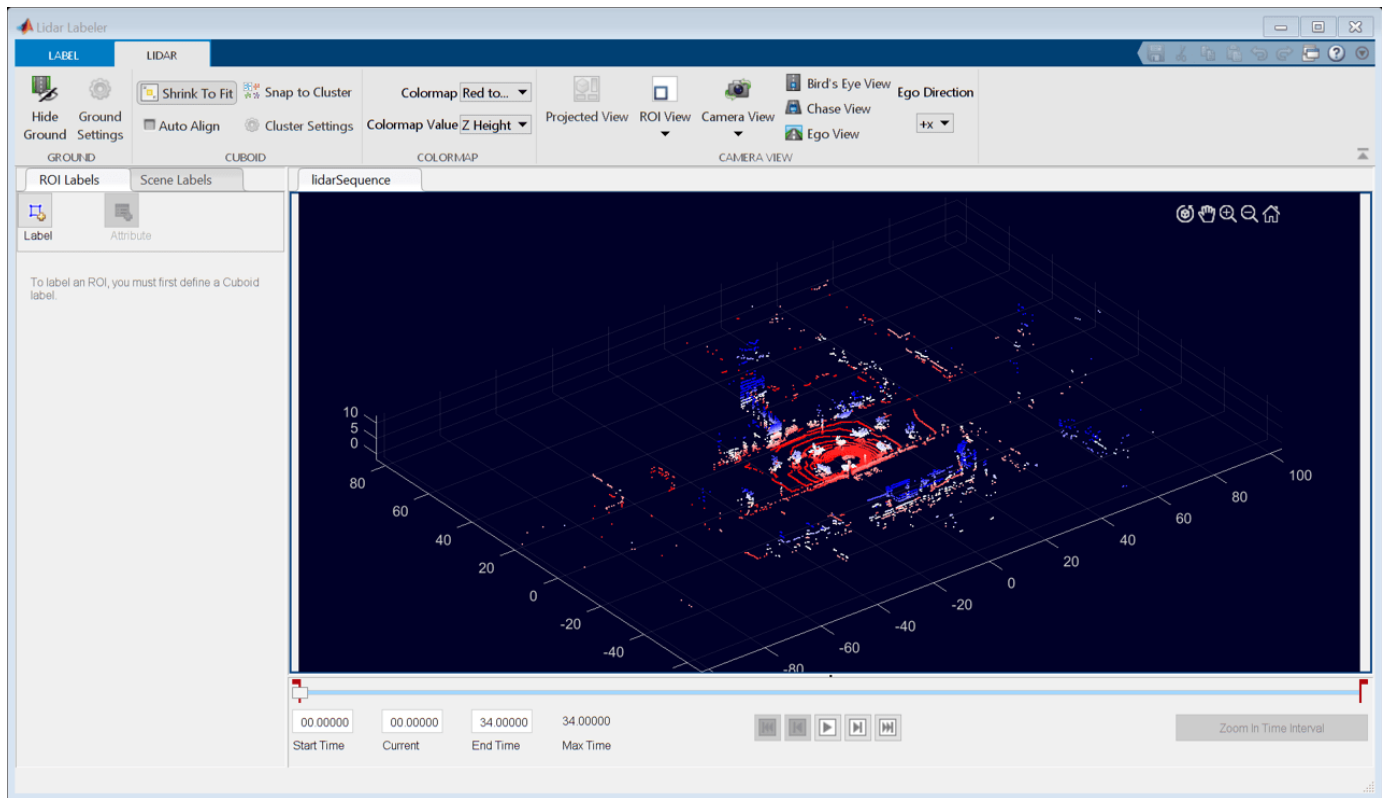

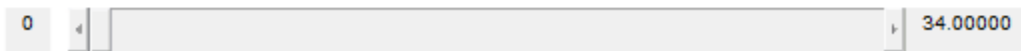

## Export the Labels

On the **LABEL** tab of the app toolstrip, select **Export Labels > To Workspace**. In the Export to workspace window, leave the default export variable name, `gTruth`, and click **OK**. The app exports a `groundTruthLidar` object, `gTruth`, to the MATLAB workspace. This object contains the ground truth lidar label data captured from the app session.

The properties of the `groundTruthLidar` object, `gTruth`, contain information about the signal data source, label definitions, and labels from the associated app session. Display information about the object and each of its properties using these commands.

- `gTruth` — Display the properties of the `groundTruthLidar` object.
- `gTruth.DataSource` — Display the information about source of the point cloud data.
- `gTruth.LabelDefinitions` — Display the table of information about label definitions.
- `gTruth.LabelData` — Display the ROI and scene label data.

## See Also

**Apps**  
**Lidar Labeler**

**Objects**  
`groundTruthLidar` | `labelDefinitionCreatorLidar`

## **More About**

- “Choose an App to Label Ground Truth Data”
- “Keyboard Shortcuts and Mouse Actions for Lidar Labeler” on page 2-12

## Keyboard Shortcuts and Mouse Actions for Lidar Labeler

**Note** On Macintosh platforms, use the **Command** (⌘) key instead of **Ctrl**.

### Label Definitions

Task	Action
Navigate through ROI labels and their groups in the <b>ROI Label Definition</b> pane.	Up or Down arrow
Navigate through scene labels and their groups in the <b>Scene Label Definition</b> pane,	Hold <b>Alt</b> and press the up arrow or down arrow
Reorder labels within a group or move labels between groups	Click and drag labels
Reorder groups	Click and drag groups

### Frame Navigation and Time Interval Settings

Navigate between frames and change the time range of the signal. These controls are located in the bottom pane of the app.

Task	Action
Go to the next frame	Right arrow
Go to the previous frame	Left arrow
Go to the last frame	<ul style="list-style-type: none"> <li>PC: <b>End</b></li> <li>Mac: Hold <b>Fn</b> and press the right arrow</li> </ul>
Go to the first frame	<ul style="list-style-type: none"> <li>PC: <b>Home</b></li> <li>Mac: Hold <b>Fn</b> and press the left arrow</li> </ul>
Navigate through time range boxes and frame navigation buttons	<b>Tab</b>
Commit time interval settings	Press <b>Enter</b> within the active time interval box ( <b>Start Time</b> , <b>Current</b> , or <b>End Time</b> )

### Labeling Window

Perform labeling actions, such as adding, moving, and deleting regions of interest (ROIs).

Task	Action
Undo labeling action	<b>Ctrl+Z</b>
Redo labeling action	<b>Ctrl+Y</b>
Select all cuboid ROIs	<b>Ctrl+A</b>
Select specific cuboid ROIs	Hold <b>Ctrl</b> and click the ROIs you want to select
Cut selected cuboid ROIs	<b>Ctrl+X</b>

Task	Action
Copy selected cuboid ROIs to clipboard	<b>Ctrl+C</b>
Paste copied cuboid ROIs	<b>Ctrl+V</b>
Switch between selected cuboid ROI labels.	<b>Tab</b> or <b>Shift+Tab</b>
Delete selected Cuboid ROIs	<b>Delete</b>

## Cuboid Resizing and Moving

Draw cuboids to label lidar point clouds. For examples on how to use these shortcuts to label lidar point clouds efficiently, see “Label Lidar Point Clouds for Object Detection” (Automated Driving Toolbox).

**Note** To enable these shortcuts, you must first click within the point cloud frame to select it.

Task	Action
Resize a cuboid uniformly across all dimensions before applying it to the point cloud	Hold <b>A</b> and move the scroll wheel up to increase size or down to decrease size
Resize a cuboid along only the x-dimension before applying it to the point cloud	Hold <b>X</b> and move the scroll wheel up to increase size or down to decrease size
Resize a cuboid along only the y-dimension before applying it to the point cloud	Hold <b>Y</b> and move the scroll wheel up to increase size or down to decrease size
Resize a cuboid along only the z-dimension before applying it to the point cloud	Hold <b>Z</b> and move the scroll wheel up to increase size or down to decrease size
Resize a cuboid after applying it to the point cloud	Click and drag one of the cuboid faces
Move a cuboid	Hold <b>Shift</b> and click and drag one of the cuboid faces  The cuboid is translated along the dimension of the selected face.
Move multiple cuboids simultaneously	Follow these steps:  <ol style="list-style-type: none"> <li><b>1</b> Hold <b>Ctrl</b> and click the cuboids that you want to move.</li> <li><b>2</b> Hold <b>Shift</b> and click and drag a face of one of the selected cuboids.</li> </ol> <p>The cuboids are translated along the dimension of the selected face.</p>

## Zooming, Panning, and Rotating

Task	Action
Zoom in on or out of a point cloud frame	In the top-left corner of the display, click the Zoom In or Zoom Out button. Then, move the scroll wheel up (zoom in) or down (zoom out). Alternatively, move the cursor up or right (zoom in) or down or left (zoom out).  Zooming in and out is supported in all modes (pan, zoom, and rotate).
Pan across a point cloud frame	Hold <b>Shift</b> and press the up, down, left, or right arrows
Rotate a point cloud frame	Hold <b>R</b> and click and drag the point cloud frame  <b>Note</b> Only yaw rotation is allowed.

## App Sessions

Task	Action
Save current session	<b>Ctrl+S</b>

## See Also

Lidar Labeler

## More About

- “Get Started with the Lidar Labeler” on page 2-2

## Use Custom Point Cloud Source Reader for Labeling

The **Lidar Labeler** app enables you to label ground truth data in point clouds. You can use a custom reader to import the data. First, create a custom reader function. Then, load the custom reader function and corresponding point cloud data source into the **Lidar Labeler**.

### Create Custom Reader Function

Specify a custom reader as a function handle. The custom reader must have this syntax.

```
outputPointCloud = readerFcn(sourceName,currentTimestamp)
```

In this example, `readerFcn` is the name of the custom reader function.

The custom reader function loads a point cloud from `sourceName`, which corresponds to the current timestamp specified by `currentTimestamp`. For example, suppose you want to load the point cloud at the third timestamp for a timestamp duration vector that runs from 1 to 5 seconds. To specify `currentTimestamp`, at the MATLAB command prompt, enter this code.

```
timestamps = seconds(1:5);
currIdx = 3;
currentTimestamp = timestamps(currIdx);
```

`outputPointCloud` from the custom reader function must be a `pointCloud` object. `currentTimestamp` is a scalar value that corresponds to the current frame that the function is executing.

### Import Data Source into Lidar Labeler App

To import a custom data source into the app, first create a structure. This structure stores the function handle and timestamps. Specify the custom reader function handle that reads the data, and the timestamps.

```
sourceParams = struct();
sourceParams.FunctionHandle = readerFcn;
sourceParams.Timestamps = timestamps;
```

To load this structure into the app, at the MATLAB command prompt, enter this code.

```
lidarLabeler(sourceName,@sourceParams.FunctionHandle,sourceParams.Timestamps);
```

Alternatively, on the toolstrip of the **Lidar Labeler** app, select **Import > Add Point Cloud**. Then, in the Select Point Cloud dialog box, choose **Custom Point Cloud** as the **Source Type**. Specify **Custom Reader Function** as the function handle and also specify **Source Name**. In addition, you must import corresponding timestamps from the MATLAB workspace.

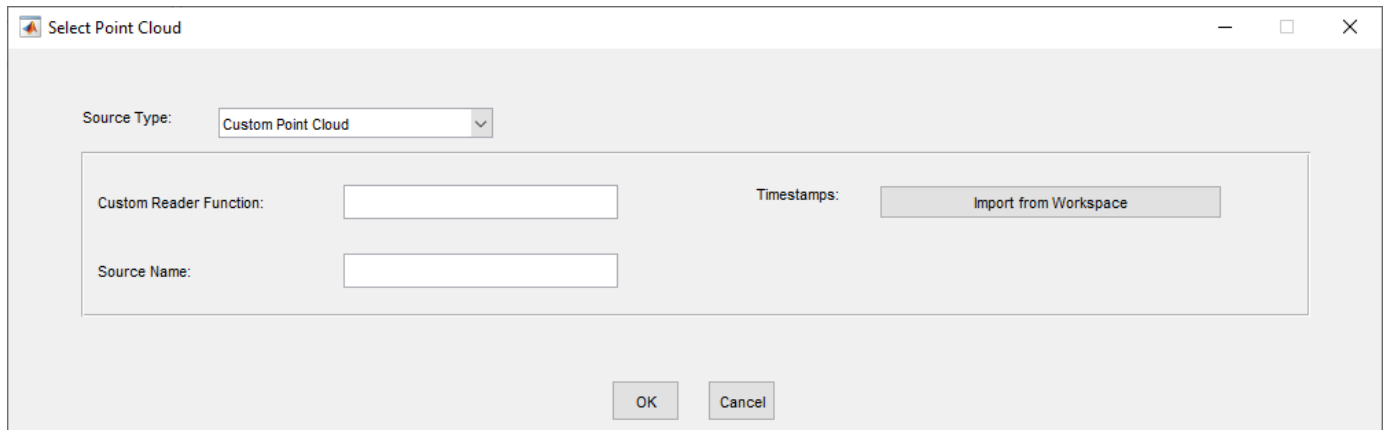

### See Also

#### Apps

Lidar Labeler

#### Classes

`lidar.labeler.loading.CustomPointCloudSource` |  
`vision.labeler.loading.MultiSignalSource`

### More About

- “Get Started with the Lidar Labeler” on page 2-2



## Create Automation Algorithm for Labeling

The **Lidar Labeler** app enables you to label ground truth for a variety of data sources. You can use an automation algorithm to automatically label your data by creating and importing a custom automation algorithm.

### Create New Algorithm

The `lidar.labeler.AutomationAlgorithm` class enables you to define a custom label automation algorithm for use in the **Lidar Labeler** app. You can use the class to define the interface used by the app to run an automation algorithm.

To define and use a custom automation algorithm, you must first define a class for your algorithm and save it to the appropriate folder.

#### Create Automation Folder

Create a `+lidar/+labeler/` folder within a folder that is on the MATLAB path. For example, if the folder `/local/MyProject` is on the MATLAB path, then create the `+lidar/+labeler/` folder hierarchy as follows:

```
projectFolder = fullfile('local','MyProject');
automationFolder = fullfile('+lidar','+labeler');
mkdir(projectFolder,automationFolder)
```

The resulting folder is located at `/local/MyProject/+lidar/+labeler`.

#### Define Class That Inherits from AutomationAlgorithm Class

At the MATLAB command prompt, enter the command: `lidarLabeler` to open the **Lidar Labeler** app.

Then, load a data source, create at least one label definition, and on the app toolstrip, select **Select Algorithm > Add Algorithm > Create New Algorithm**. In the `lidar.labeler.AutomationAlgorithm` class template that opens, define your custom automation algorithm. Follow the instructions in the header and comments in the class.

If the algorithm is time-dependent, that is, has a dependence on the timestamp of execution, your custom automation algorithm must also inherit from the `lidar.labeler.mixin.Temporal` class. For more details on implementing time-dependent, or temporal, algorithms, see “Temporal Automation Algorithms” on page 2-21.

#### Save Class File to Automation Folder

To use your custom algorithm from within the labeling app, save the file to the `+lidar/+labeler` folder that you created. Make sure that this folder is on the MATLAB search path. To add a folder to the path, use the `addpath` function.

#### Refresh Algorithm List in Labeling App

To start using your custom algorithm, refresh the algorithm list so that the algorithm displays in the app. On the app toolstrip, select **Select Algorithm > Refresh list**.

## Import Existing Algorithm

To import an existing custom algorithm into a labeling app, on the app toolbar, select **Select Algorithm > Add Algorithm > Import Algorithm** and then refresh the list.

## Custom Algorithm Execution

When you run an automation session in a labeling app, the properties and methods in your automation algorithm class control the behavior of the app.

### Check Label Definitions

When you click **Automate**, the app checks each label definition in the **ROI Labels** and **Scene Labels** panes by using the `checkLabelDefinition` method defined in your custom algorithm. Label definitions that return `true` are retained for automation. Label definitions that return `false` are disabled and not included. Use this method to choose a subset of label definitions that are valid for your custom algorithm. For example, if your custom algorithm is a semantic segmentation algorithm, use this method to return `false` for label definitions that are not of type `Voxel`.



### Control Settings

After you select the algorithm, click **Automate** to start an automation session. Then, click **Settings**, which enables you to modify custom app settings. To control the **Settings** options, use the `settingsDialog` method.



## Control Algorithm Execution

When you open an automation algorithm session in the app and then click **Run**, the app calls the `checkSetup` method to check if it is ready for execution. If the method returns `false`, the app does not execute the automation algorithm. If the method returns `true`, the app calls the `initialize` method and then the `run` method on every frame selected for automation. Then, at the end of the automation run, the app calls the `terminate` method.

The diagram shows this flow of execution for the labeling apps.

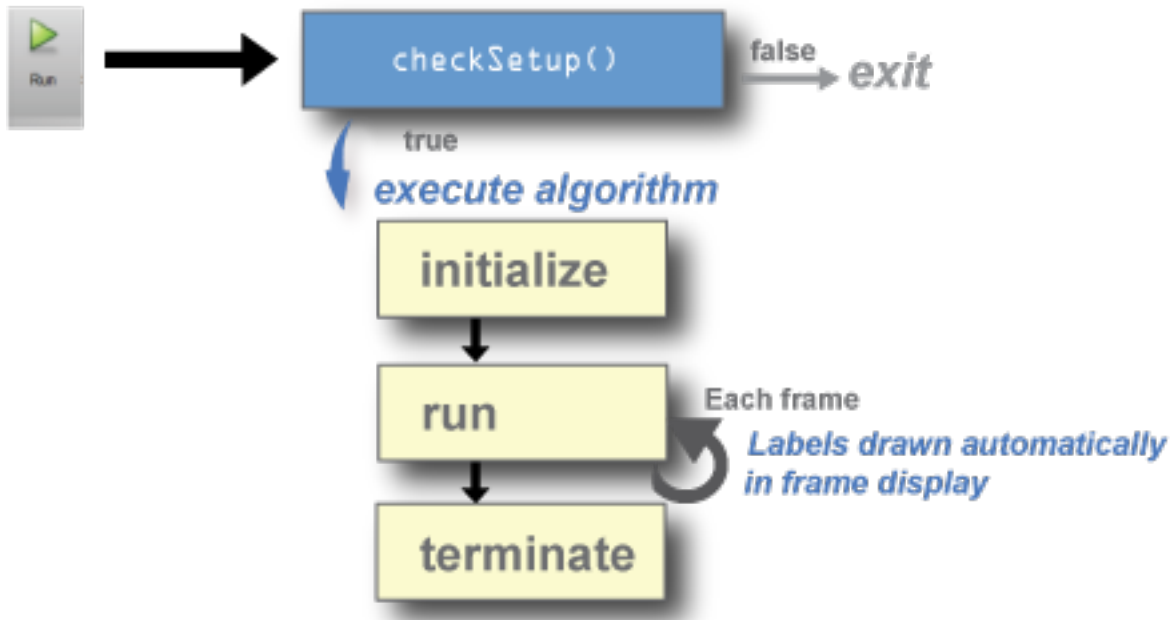

- Use the `checkSetup` method to check whether all conditions needed for your custom algorithm are set up correctly. For example, before running the algorithm, check that the scene contains at least one ROI label.
- Use the `initialize` method to initialize the state for your custom algorithm by using the frame.
- Use the `run` method to implement the core of the algorithm that computes and returns labels for each frame.
- Use the `terminate` method to clean up or terminate the state of the automation algorithm after the algorithm runs.

## See Also

### Apps

[Video Labeler](#) | [Image Labeler](#) | [Ground Truth Labeler](#) | [Lidar Labeler](#)

### Functions

`lidar.labeler.AutomationAlgorithm` | `lidar.labeler.mixin.Temporal`

## **Related Examples**

- “Automate Ground Truth Labeling For Vehicle Detection Using PointPillars” on page 1-289
- “Automate Ground Truth Labeling for Lidar Point Cloud Semantic Segmentation Using Lidar Labeler” on page 1-55

## **See Also**

## **More About**

- “Get Started with the Lidar Labeler” on page 2-2
- “Temporal Automation Algorithms” on page 2-21

## Temporal Automation Algorithms

The **Lidar Labeler** app enables you to create and import a custom automation algorithm to automatically label your data. Automation algorithms can be time-independent or time-dependent.

- Time-independent (nontemporal) algorithms can operate independently on each timestamp.
- Time-dependent (temporal) algorithms have a dependence on the timestamp of execution. For example, a tracking algorithm, such as the temporal built-in Lidar Object Tracker, uses tracking from a previous time stamp to track objects in the current time stamp.

### Create Temporal Automation Algorithm

To create a temporal automation algorithm to use with **Lidar Labeler** app, on the app toolstrip, select **Select Algorithm > Add Algorithm > Create New Algorithm**. A class template opens, enabling you to define your algorithm. By default, the class inherits from the `lidar.labeler.AutomationAlgorithm` and `lidar.labeler.mixin.Temporal` classes, as shown by the class definition of the template:

```
classdef MyCustomAlgorithm < lidar.labeler.AutomationAlgorithm && lidar.labeler.mixin.Temporal
```

Time-based algorithms must inherit from both of these classes. Inheriting from the temporal mixin class enables you to access properties such as `StartTime`, `CurrentTime` and `EndTime` to design time-based algorithms. For more details on enabling temporal properties, see the `lidar.labeler.mixin.Temporal` class reference page. For more details on defining custom automation algorithms in general, see the `lidar.labeler.AutomationAlgorithm` class reference page.

After creating your algorithm, follow the instructions in the class template on where to save the algorithm.

### Run Temporal Automation Algorithm

To run your temporal algorithm from the labeling, first refresh the algorithm list. On the app toolstrip, select **Select Algorithm > Refresh list**. Then, reopen the **Select Algorithm** list, select your algorithm, and run it on your data as you would any of the built-in automation algorithms.

For temporal algorithms, you can additionally configure the direction of automation. Click **Configure Automation**. By default, automation algorithms apply labels from the start of the time interval to the end. To change the direction and start time of the algorithm, choose one of the options shown in this table.

Direction of automation	Run automation from	Example
Direction of automation: <input type="radio"/> Forward <input type="radio"/> Reverse	Run automation from: <input type="radio"/> Start time to End time <input type="radio"/> Current time to End time	
	Run automation from: <input type="radio"/> Start time to End time <input checked="" type="radio"/> Current time to End time	

Direction of automation	Run automation from	Example
Direction of automation: <input type="radio"/> Forward <input checked="" type="radio"/> Reverse	Run automation from: <input type="radio"/> End time to Start time <input checked="" type="radio"/> Current time to Start time	A diagram showing a horizontal timeline with a blue line representing a range. A white square is positioned on the blue line. A yellow arrow points from the white square to the left, indicating automation from the current time to the start time. Red vertical bars are at both ends of the blue line.
	Run automation from: <input type="radio"/> End time to Start time <input checked="" type="radio"/> Current time to Start time	A diagram showing a horizontal timeline with a blue line representing a range. A white square is positioned on the blue line. A yellow arrow points from the right end of the blue line to the left, indicating automation from the end time to the start time. Red vertical bars are at both ends of the blue line.

## See Also

### Apps

[Lidar Labeler](#) | [Image Labeler](#) | [Ground Truth Labeler](#)

### Functions

`lidar.labeler.AutomationAlgorithm` | `lidar.labeler.mixin.Temporal`

## Related Examples

- “Automate Ground Truth Labeling For Vehicle Detection Using PointPillars” on page 1-289
- “Automate Ground Truth Labeling for Lidar Point Cloud Semantic Segmentation Using Lidar Labeler” on page 1-55

## See Also

### More About

- “Get Started with the Lidar Labeler” on page 2-2
- “Create Automation Algorithm for Labeling” on page 2-17

# Lidar Viewer Tutorial

---

## Create Custom Preprocessing Workflow with Lidar Viewer

The **Lidar Viewer** app is a tool for visualization, analysis, and preprocessing of lidar data. You can use this app to prepare your lidar data for advanced workflows such as labeling, segmentation, and calibration. The **Lidar Viewer** app offers several built-in preprocessing algorithms for use with lidar data, but it can also help you create custom preprocessing algorithms and integrate them into your preprocessing workflow.

Using the **Lidar Viewer** app, you can:

- Create custom preprocessing algorithms and use them interactively within the **Lidar Viewer** app.
- Combine custom preprocessing algorithms with other built-in and custom algorithms to create reusable preprocessing workflows.

This example shows how to:

- Read the point cloud data and import it into the **Lidar Viewer** app.
- Create and use a custom preprocessing algorithm to radially crop the point cloud.
- Combine the custom radial cropping algorithm with a built-in algorithm to convert the unorganized point cloud to an organized point cloud.
- Export the combined custom preprocessing workflow for reuse.

### Read Point Cloud Data

Read the point cloud data into the workspace using the `pcread` function. This example uses the Ouster point cloud data.

```
% Read Ouster Point Cloud Data
fileName = fullfile(matlabroot,"examples","deeplearning_shared","data");
fileName = fullfile(fileName,"ousterLidarDrivingData.pcd");
ptCloud = pcread(fileName);
```

To determine whether the point cloud data is organized or unorganized, display the size of the `Location` property of the `ptCloud` object `ptCloud`. If the point cloud coordinates are in the form, *M-by-N-by-3*, the point cloud is an organized point cloud. If the point cloud coordinates are in the form, *M-by-3*, the point cloud is an unorganized point cloud.

```
disp(size(ptCloud.Location))

        64         1024         3
```

For more information about the organized and unorganized point clouds, see “What are Organized and Unorganized Point Clouds?” on page 4-17

### Load Point Cloud Data into Lidar Viewer

Open the **Lidar Viewer** app from the MATLAB command prompt, by entering this command.

```
lidarViewer
```

Alternatively, you can select the app from the **Image Processing and Computer Vision** section of the **Apps** tab.



On the app toolstrip, select **Import > From Workspace**. In the **Import from Workspace** dialog box, select *ptCloud* and click **OK**.

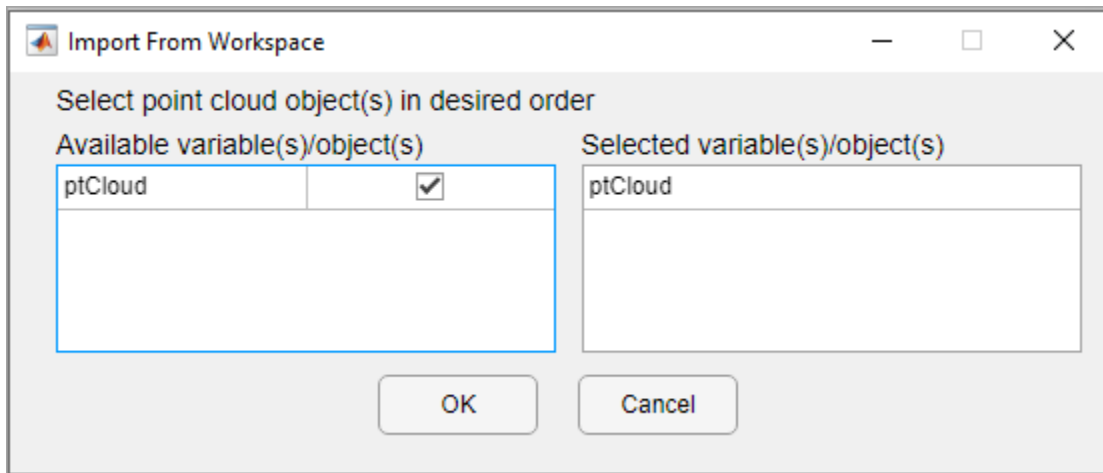

The app loads the point cloud data and displays it in the **Point Cloud Display** pane.

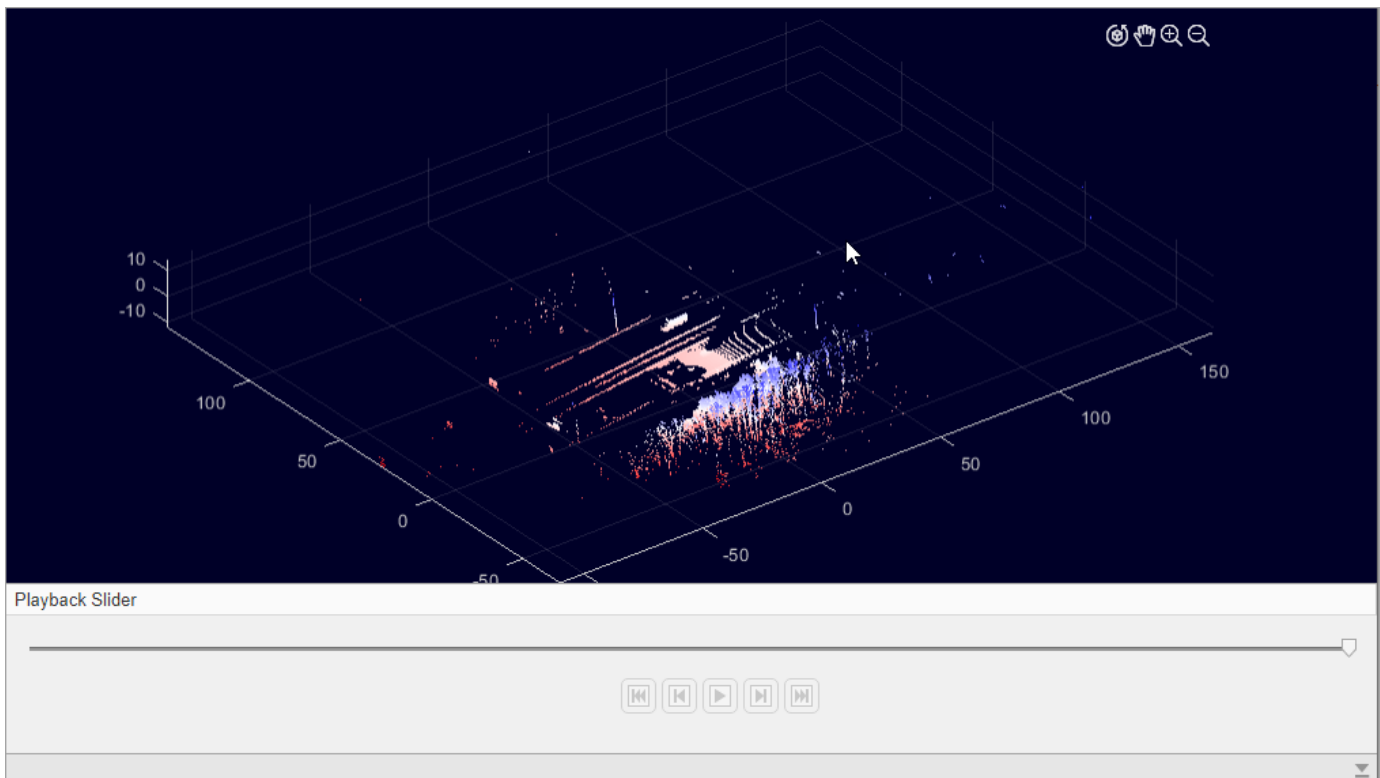

## Create Custom Preprocessing Algorithm

### Create Custom Algorithm

On the app toolstrip, select **Edit Point Cloud** to open the **Edit** tab. You can create custom spatial and temporal preprocessing algorithms in class-based and function-based formats and import them into

the app. To create a class-based spatial preprocessing algorithm, first click **Add Algorithm** and select **New > Class Template** from the **Spatial Algorithms** section.

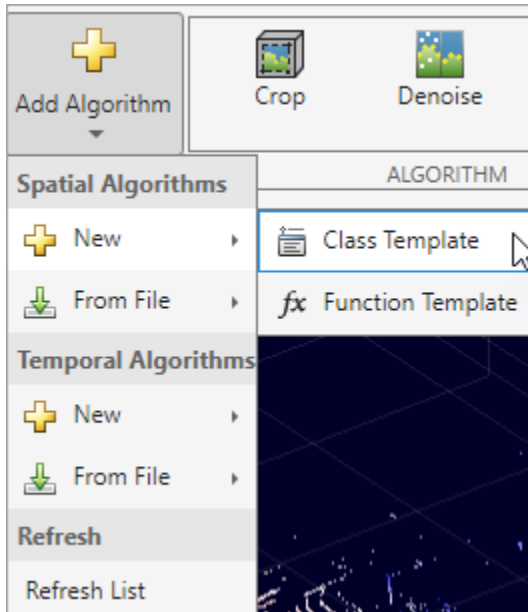

MATLAB opens a new script containing boilerplate code and instructions for creating a class-based definition for your custom algorithm. Using this code, you can also define user interface elements for tuning the algorithm parameters in the **Algorithm Parameters** pane.

### Write Custom Preprocessing Class Definition

Create a `+lidar/+lidarViewer` package directory within a folder that is already on the MATLAB path to save the custom preprocessing class definition.

These are the steps to write a custom preprocessing class definition inherited from `lidar.internal.lidarViewer.edits.EditAlgorithm`.

- 1 Define descriptive properties for the algorithm, such as a unique `EditName`, `Icon`, and `Description`.
- 2 Define the properties that manage algorithm execution.  
(Optional) Define a method that overwrites the initialization method of the superclass.
- 3 Define methods to capture parameters and set up the user-interface panel.
  - a Define a method to package parameters in a structure.
  - b Create the user-interface panel and configure it to capture parameters.
  - c Define a callback function for the user-interface panel.
- 4 Define the method that processes the point cloud.

For example, to radially crop the point cloud i.e. discard points outside a spherical region of certain radius, write the custom preprocessing class definition as follows.

```
% Copyright 2021 The MathWorks, Inc.
```

```

% Name the class as radialCrop by replacing the default value
classdef radialCrop < lidar.internal.lidarViewer.edits.EditAlgorithm

%-----
% Step 1: Define the properties that describe the alogorithm. These
% properties include a unique EditName, Icon and Description
% of the edit algorithm. The name of the algorithm and the icon
% will be displayed in the edit algorithm gallery.
properties (Constant)
    % Name the algorithm
    EditName = 'Radial Crop';
    % Set an icon
    Icon = fullfile(matlabroot, 'toolbox', 'lidar', 'lidar', ...
        '+lidar', '+internal', '+lidarViewer', '+view', ...
        '+icons', 'customClassEdit_24.png');
    % Give a description
    Description = "Discard points outside a certain radius";
end

%-----
% Step 2: Define properties to use in the algorithm.
% These properties are user-defined.
properties
    % User interface elements defined as properties of the class
    elementsUI
end

%
%-----
% Optional Step: Define this method to set up the class properties.
% methods
% a) This is an optional method.
% The super class initializes the PointCloud property that
% stores the point cloud object present in the current frame
% when this edit operation is called. Overwrite this method if
% additional steps are required.
%
% Use this function as an initialization step.
%
function setUpEditOperation(this, ptCld)
    this.PointCloud = ptCld;
%-----
% Place your code here
%-----
end

% end

%-----
% Step 3: Define methods to capture the algorithm parameters and to
% configure the panel.
methods
    % a) This function packages the algorithm parameters into a
    % structure, params. This structure is passed to the
    % applyEdits() function defined below. This function call
    % process the input point cloud. The structure must be
    % compatible with the one used in applyEdits() function.
    function params = getCurrentParams(this)
        % Create empty structure
        params = struct();
    end
end

```

```

        % Add user-defined parameter Radius as struct field
        params.Radius = this.elementsUI.Value;
    end

    % b) This function creates the configuration panel with the
    %     UI components required to tune the algorithm.
    function setUpAlgorithmConfigurePanel(this, panel)
        % Label for numeric edit field
        uilabel(panel,Position=[25 150 100 22],Text="Radius");
        % Create numeric edit field with callback
        this.elementsUI = uieditfield(panel,"numeric", ...
            ValueChangedFcn= ...
            @(elementsUI,event) configurationPanelCallback(this));
        % Set position of edit field
        this.elementsUI.Position = [75 150 100 22];
        % Set initial value of parameter
        this.elementsUI.Value = 0;
        % Set limits for parameter input
        this.elementsUI.Limits = [0 inf];
        % Set decimal display format of edit field
        this.elementsUI.ValueDisplayFormat = "%.2f";
    end

    % Define callback function for configuration panel.
    % This function is not given in the boilerplate code.
    function configurationPanelCallback(this)
        % To see the real-time output on changing the parameters
        evt = this.createEventData();
        notify(this,"PointCloudChanging",evt);
        % Get current parameters on event in user-interface
        getCurrentParams(this);
    end
end

%-----
% Step 4: Define method to process the input point cloud object
% using the parameters passed.
methods (Static)
    % a) This function calls the algorithm to process the point
    %     cloud using the parameters defined in params. Note that
    %     the param structure is created using the getCurrentParams()
    %     function defined above.
    function ptCldOut = applyEdits(ptCldIn, params)
        % Find points in spherical region
        [croppedLocations, ~] = ...
            findNeighborsInRadius(ptCldIn,[0 0 0],params.Radius);
        % Crop point cloud
        ptCldOut = select(ptCldIn,croppedLocations);
    end
end
end

end

```

Save the algorithm class file to the package directory.

## Import and Use Custom Preprocessing Algorithm

To import the algorithm into **Lidar Viewer**, on the app toolbar, select **Add Algorithm > From File > Import Class** from the **Spatial Algorithms** section. Then, in the dialog box, select the algorithm class file and click **Open**, adding the custom algorithm to the **Spatial Algorithms** section of the toolbar. If you do not see the custom algorithm on the toolbar, select **Add Algorithm > Refresh List**.

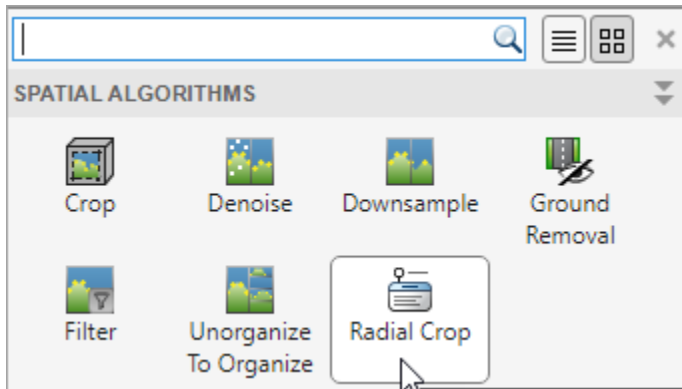

Select your algorithm and tune the parameters in the user-interface.

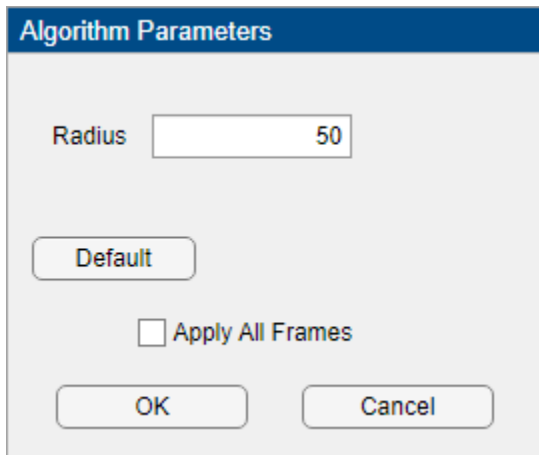

The **Lidar Viewer** app dynamically updates the point cloud as you tune the parameters, enabling you to see the results in real-time.

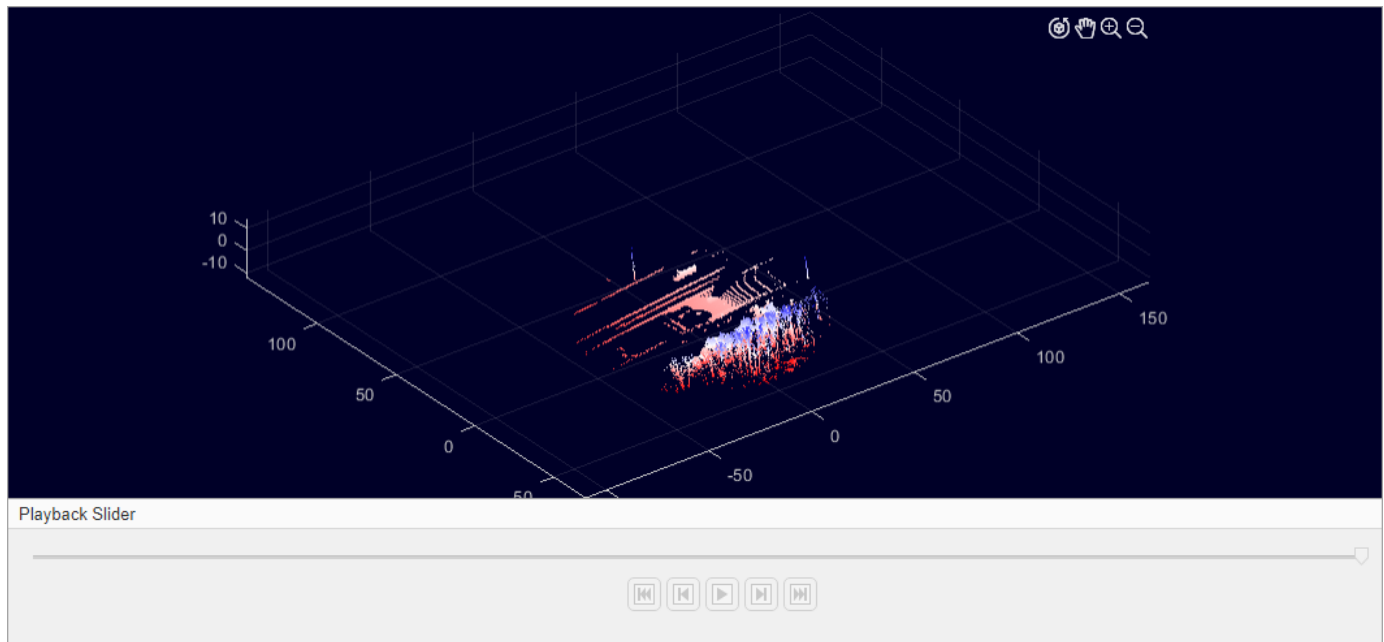

After tuning the parameters, select **OK**. The **History** pane records the preprocessing operation.

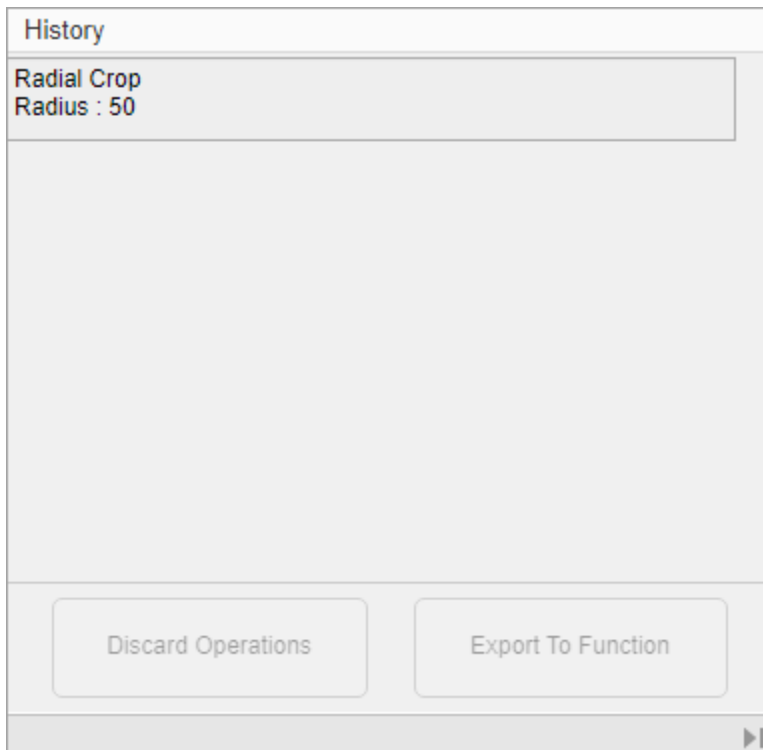

To finish editing using this algorithm, select **Cancel**.

Your preprocessed point cloud is ready for export. However, if you wish to create a custom preprocessing workflow with multiple preprocessing steps, you can combine multiple preprocessing algorithms.

## Combine Multiple Preprocessing Algorithms

The custom radial cropping operation generates an unorganized point cloud. To convert the unorganized point cloud to an organized point cloud, use the built-in **Unorganize to Organize** algorithm. To configure the algorithm for the Ouster sensor used to capture the point cloud data, in the **Algorithm Parameters** pane, specify **Sensor Name** as *OS1Gen1-64*.

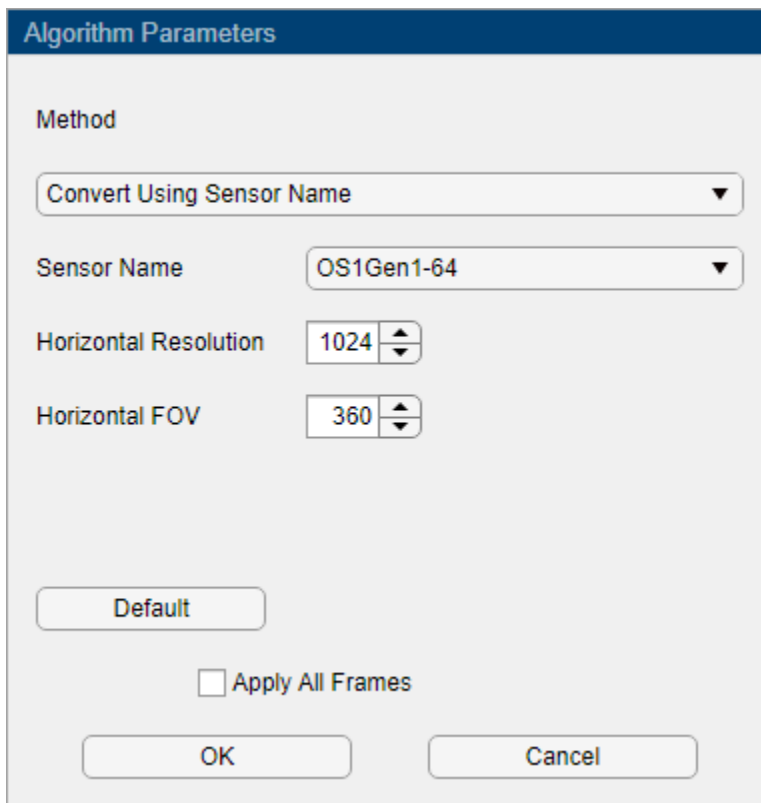
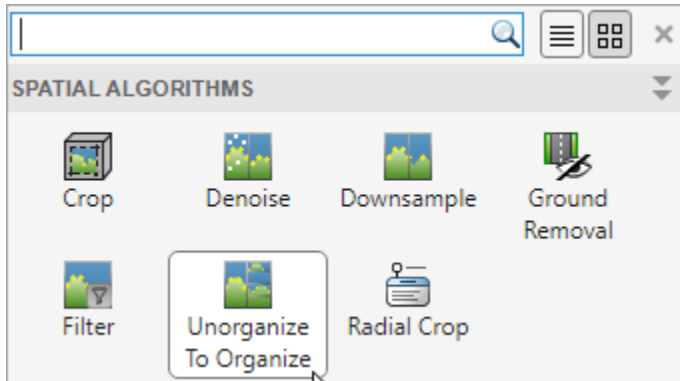

After tuning the parameters, select **OK**. The **History** pane records the preprocessing operation.

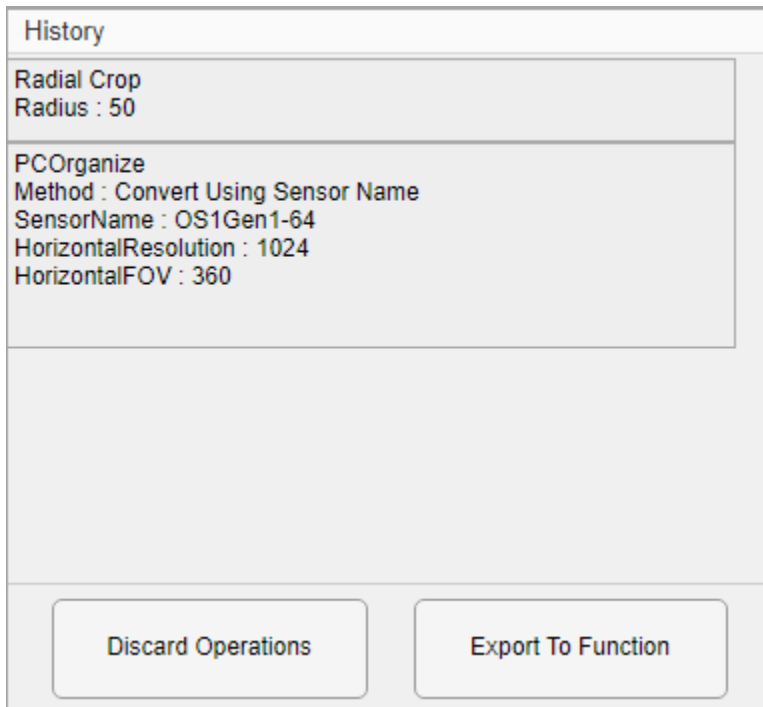

To finish editing using this algorithm, select **Cancel**.

## Export Custom Preprocessing Workflow to MATLAB Function

Export this combination of preprocessing operations, with their parameters, as a function for future reuse. In the **History** pane, select **Export To Function**. The app creates a function script containing your custom preprocessing workflow function. Save this function with an appropriate name. The function accepts a `pointCloud` object as input and outputs a processed `pointCloud` object. To finalize your edits to the point cloud and return to the **Lidar Viewer** tab, on the app toolbar, select **Accept**.

To use the exported preprocessing function, from the **Edit** tab of the **Lidar Viewer** toolbar, select **Add Algorithm > From File > Import Function** in the **Spatial Algorithms** section, and select the exported function. You can then apply the imported function to the point cloud directly from the **Algorithm** section of the toolbar.



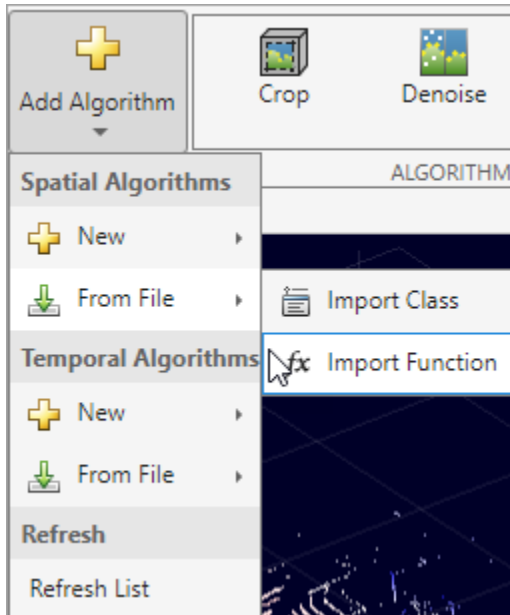

## Export Point Cloud Data from Lidar Viewer

You can export point clouds as PCD or PLY files. After processing the point cloud, on the app toolstrip, select **Export Point Cloud**.

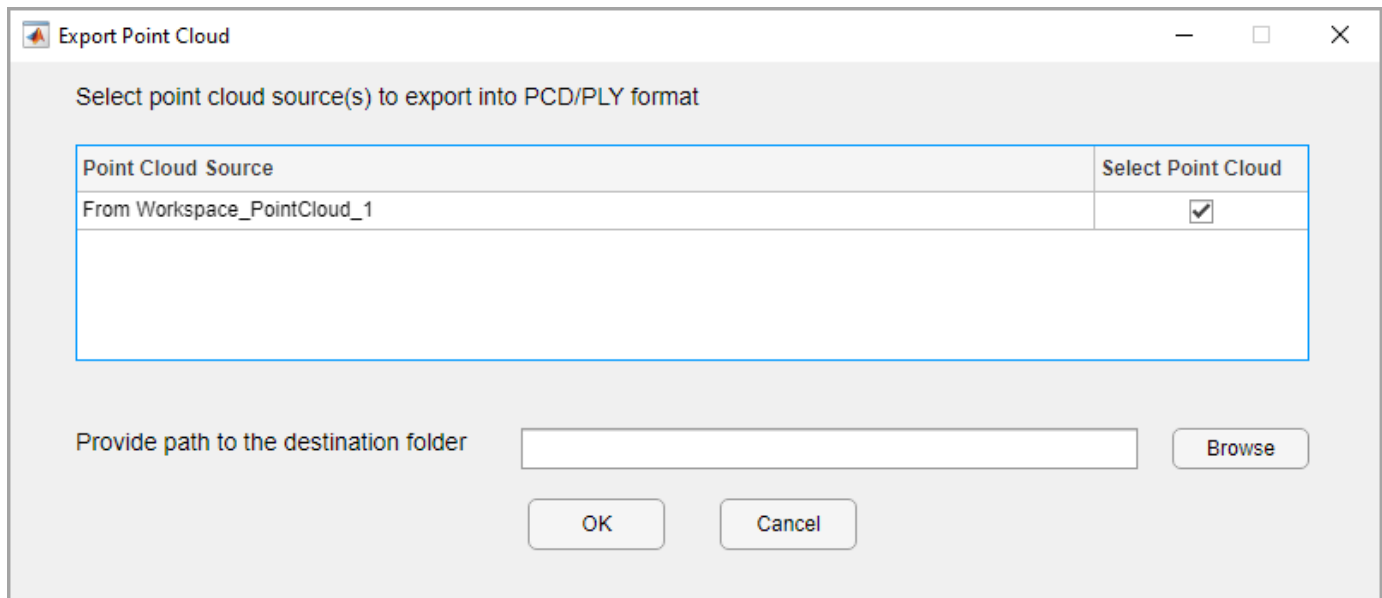

In the **Export Point Cloud** dialog box, select the preprocessed point cloud. Then, in the **Provide path to the destination folder** box, specify a destination file path or browse to the destination folder. To export the point cloud to the specified destination, select **OK**.

## **See Also**

### **Apps**

Lidar Viewer

### **Functions**

pcread

### **Objects**

pointCloud

## **More About**

- “Get Started with Lidar Viewer” on page 4-32

# Concept Pages

---

- “Introduction to Lidar” on page 4-2
- “Coordinate Systems in Lidar Toolbox” on page 4-7
- “What Is Lidar-Camera Calibration?” on page 4-10
- “Calibration Guidelines” on page 4-14
- “What are Organized and Unorganized Point Clouds?” on page 4-17
- “Parameter Tuning for Ground Segmentation” on page 4-20
- “Get Started with Lidar Camera Calibrator” on page 4-21
- “Get Started with Lidar Viewer” on page 4-32
- “Getting Started with PointPillars” on page 4-49
- “Getting Started with PointNet++” on page 4-52

## Introduction to Lidar

### What is Lidar?

Lidar, which stands for Light Detection and Ranging, is a method of 3-D laser scanning.

Lidar sensors provide 3-D structural information about an environment. Advanced driving assistance systems (ADAS), robots, and unmanned aerial vehicles (UAVs) employ lidar sensors for accurate 3-D perception, navigation, and mapping.

Lidar is an active remote sensing system that uses laser light to measure the distance of the sensor from objects in a scene. A lidar sensor emits laser pulses that reflect off of surrounding objects. The sensor then captures this reflected light and uses the time-of-flight principle to measure its distance from objects, enabling it to perceive the structure of its surroundings.

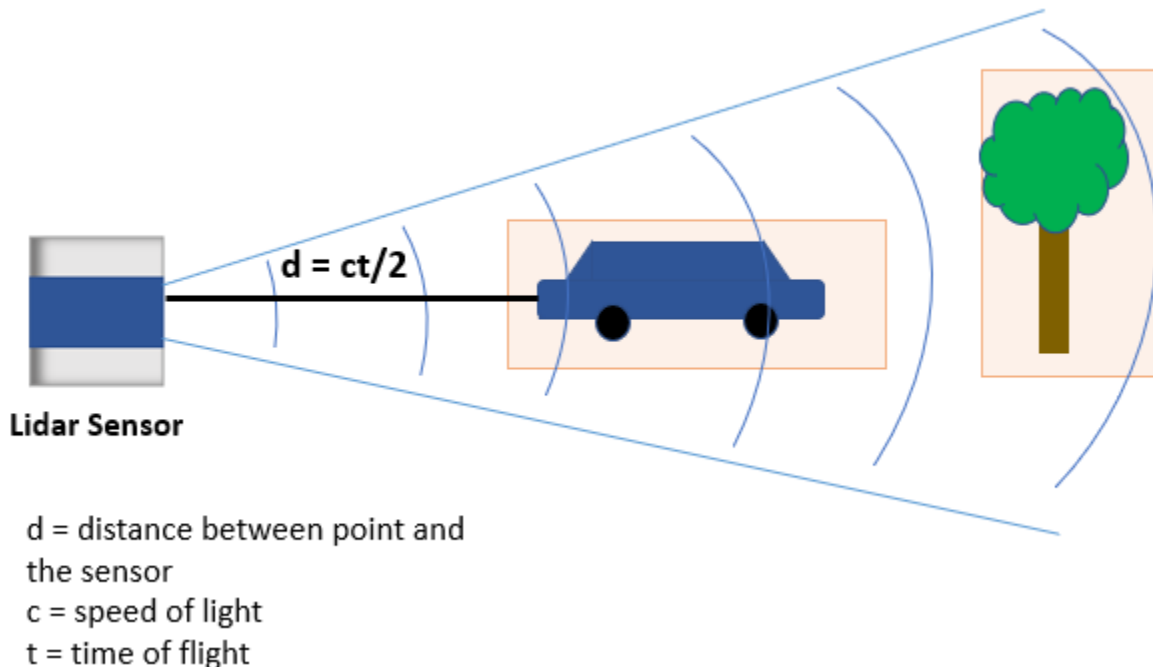

A lidar sensor stores these reflected laser pulses, or laser returns, as a collection of points. This collection of points is called a point cloud.

### What is a Point Cloud?

A point cloud is a collection of 3-D points in space. Just as an image is the output of a camera, a point cloud is the output of a lidar sensor.

A lidar sensor captures attributes such as the location in xyz-coordinates, the intensity of the laser light, and the surface normal at each point of a point cloud. With this information a point cloud generates a 3-D map of an environment. You can store and process the information from a point cloud in MATLAB by using a `pointCloud` object.

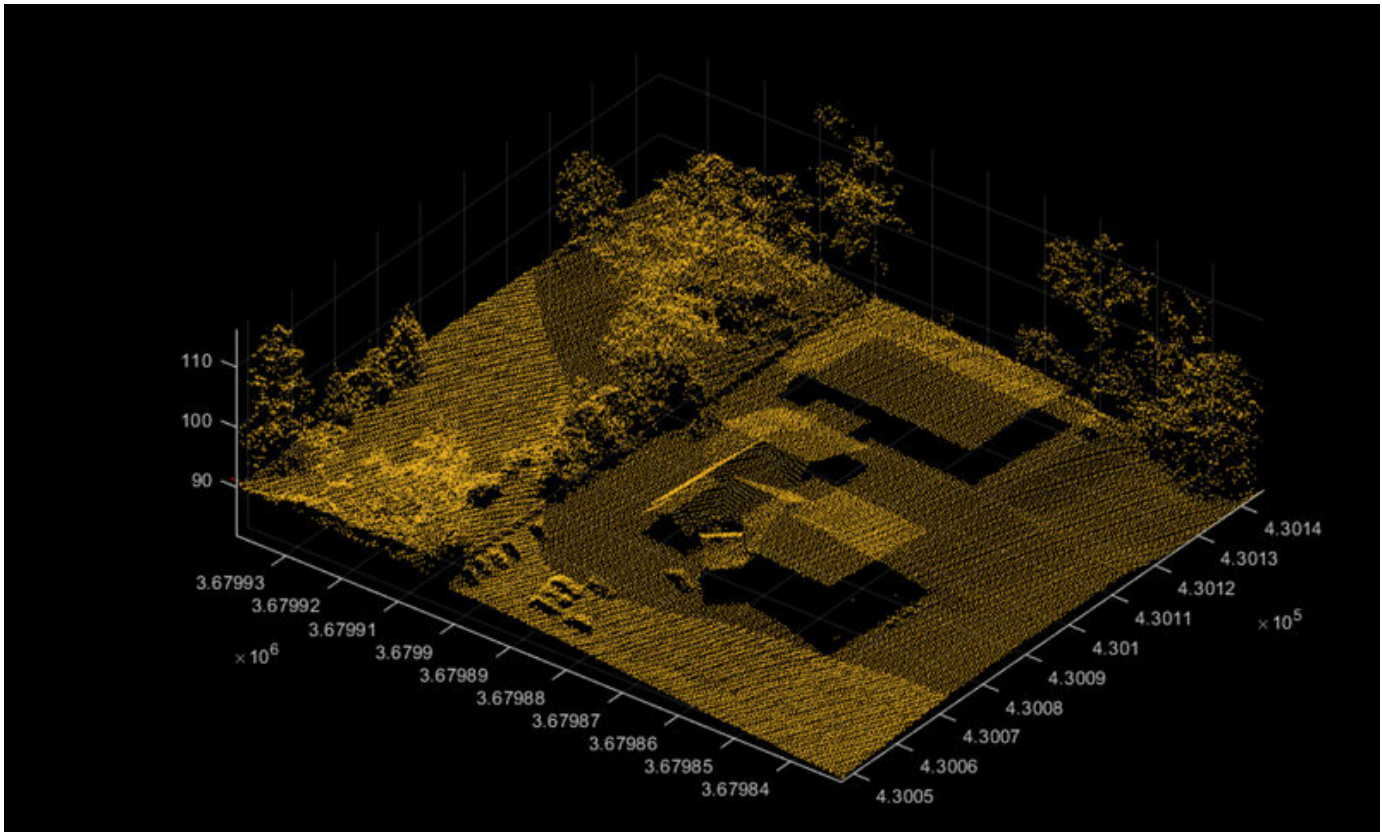

Point clouds can be either unorganized or organized. In an unorganized point cloud, the points are stored as a single stream of 3-D coordinates. In an organized point cloud, the points are arranged into rows and columns based on spatial relation between them. For more information about organized and unorganized point clouds, see “What are Organized and Unorganized Point Clouds?” on page 4-17

## Types of Lidar

You can broadly divide the various types of lidar sensors based on whether they are for airborne or terrestrial application.

### Airborne or Aerial Lidar

Airborne lidar sensors are those attached to helicopters, aircrafts, or UAVs. They consist of topographic and bathymetric sensors.

- Topographic sensors help in monitoring and mapping the topography of a region. Applications include urban planning, landscape ecology, forest planning and mapping.
- Bathymetric sensors estimate the depth of water bodies. These sensors have an additional green laser that travels through a water column. Applications include coastline management, and oceanography.



Aerial lidar sensor

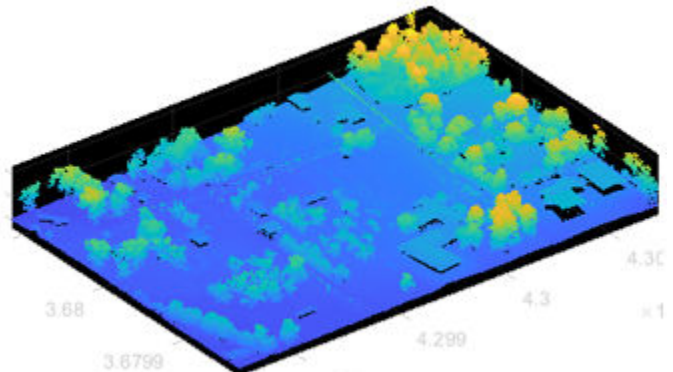

Aerial point cloud data

### Terrestrial Lidar

Terrestrial lidar sensors scan the surface of the Earth or the immediate surroundings of the sensor on land. These sensors can be static or mobile.

- Static sensors collect point clouds from a fixed location. Applications such as mining, archaeology, smartphones, and architecture use static sensors.
- Mobile sensors are most commonly used in autonomous driving systems, and are mounted on vehicles. Other applications include robotics, transport planning, and mapping.

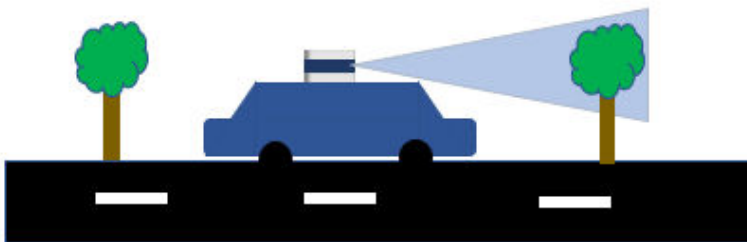

Terrestrial lidar sensor

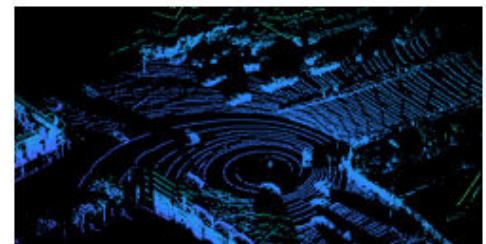

Terrestrial point cloud data

### Advantages of Lidar Technology

Lidar sensors are useful when you need to take accurate measurements at longer distances and higher resolutions than is possible with radar sensors, or in environmental or lighting conditions that would negatively affect a camera. Lidar scans are also natively 3-D, and do not require additional software to add depth.

You can use lidar sensors to detect small details, scan dense environments, and collect data at night or in inclement weather, all with high speed.

## Lidar Processing Overview

### I/O and Supported Hardware

Because the wide variety of lidar sensors available from companies such as Velodyne®, Ouster®, Hesai®, and Ibeo® use a variety of formats for point cloud data, Lidar Toolbox™ provides tools to import and export point clouds using various file formats. Lidar Toolbox currently supports reading data from the PLY, PCAP, PCD, LAS, LAZ, and Ibeo data container (IDC) sensor formats. You can also write point cloud data to the PLY, PCD, and LAS formats. For more information on file input and output, see “I/O”. You can also stream live data from Velodyne and Ouster sensors. For more details on streaming live data, see “Lidar Toolbox Supported Hardware”.

### Preprocessing

Lidar Toolbox enables you perform preprocessing operations such as downsampling, denoising, and cropping on your point cloud data. To learn more about visualizing and preprocessing point clouds, see “Get Started with Lidar Viewer” on page 4-32.

### Labeling, Segmentation and Detection

Labeling objects in a point cloud helps you organize and analyze ground truth data for object detection and segmentation. To learn more about lidar labeling, see “Get Started with the Lidar Labeler” on page 2-2.

Many applications for lidar processing rely on deep learning algorithms to segment, detect, track, and analyze objects of interest in a point cloud. To learn more about point cloud processing using deep learning, see “Getting Started with Point Clouds Using Deep Learning”.

### Calibration and Sensor Fusion

Most modern sensing systems use sensor suites that contain multiple sensors. To obtain meaningful information from multiple sensors, you must first calibrate these sensors. Calibration is the process of aligning the coordinate systems of multiple sensors through rotational and translational transformations. For more information about coordinate systems, see “Coordinate Systems in Lidar Toolbox” on page 4-7.

Lidar Toolbox provides various tools for calibration and sensor fusion. Many applications involve capturing the same scene using both a lidar sensor and a camera. To construct an accurate 3-D scene, you must fuse the data from these sensors by first calibrating them to one another. For more information on lidar-camera fusion, see “What Is Lidar-Camera Calibration?” on page 4-10 and “Get Started with Lidar Camera Calibrator” on page 4-21.

### Navigation and Mapping

Mapping is the process of building a map of the environment around an autonomous system. You can use tools in Lidar Toolbox to perform simultaneous localization and mapping (SLAM), which is the process of calculating the position and orientation of the system, with respect to its surroundings, while simultaneously mapping its environment. For more information, see “Implement Point Cloud SLAM in MATLAB”.

## Applications of Lidar Technology

Lidar Toolbox provides many tools for typical workflows in different applications of lidar processing.

- **Autonomous Driving Assistance Systems** — You can detect cars, trucks, and other objects using the lidar sensors mounted on moving vehicles. You can semantically segment these point clouds to detect and track objects as they move. To learn more about vehicle detection and tracking using Lidar Toolbox, see the “Detect, Classify, and Track Vehicles Using Lidar” on page 1-139 example.
- **Remote Sensing** — Airborne lidar sensors can generate point clouds that provide information about the vegetation cover in an area. To learn more about remote sensing using Lidar Toolbox, see the “Extract Forest Metrics and Individual Tree Attributes from Aerial Lidar Data” on page 1-86 example.
- **Navigation and Mapping** — You can build a map using the lidar data generated from a vehicle-mounted lidar sensor. You can use these maps for localization and navigation. To learn more about map building, see the “Feature-Based Map Building from Lidar Data” on page 1-154 example.

### See Also

#### More About

- “What are Organized and Unorganized Point Clouds?” on page 4-17
- “Getting Started with Point Clouds Using Deep Learning”
- “Coordinate Systems in Lidar Toolbox” on page 4-7
- “What Is Lidar-Camera Calibration?” on page 4-10
- “Implement Point Cloud SLAM in MATLAB”



## Coordinate Systems in Lidar Toolbox

Lidar Toolbox uses these coordinate systems:

- World — A fixed, universal coordinate system in which the physical sensors exist.
- Sensor — Specific to each particular sensor, such as a lidar sensor or a camera.
- Spatial — Specific to an image captured by a camera. Locations in spatial coordinates are expressed in pixels.
- Pattern — A checkerboard pattern coordinate system, typically used to calibrate camera sensors.

### World Coordinate System

The world coordinate system is a fixed universal system that works as an absolute reference for all sensors. Lidar Toolbox uses the right-handed Cartesian world coordinate system defined in ISO 8855, where the positive  $z$ -axis points up from the ground. Units are in meters.

### Sensor Coordinate System

A sensor coordinate system in Lidar Toolbox is anchored to a specific sensor, such as a lidar sensor or a camera. The location of each sensor contains the origin of its coordinate system. For example, the optical center of a camera typically acts as the origin of the camera coordinate system. Points in the sensor coordinate system follow these axes conventions:

- The  $x$ -axis points forward from the sensor.
- The  $y$ -axis points to the left, as viewed when facing forward.
- The  $z$ -axis points up from the ground to maintain the right-handed coordinate system.

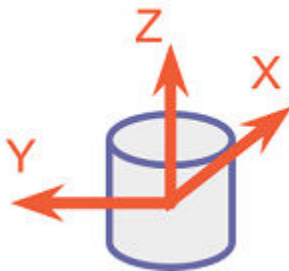

The yaw, pitch, and roll angles of sensors follow an ISO convention. These angles are clockwise-positive when looking in the positive direction of the  $z$ -,  $y$ -, and  $x$ -axes, respectively.

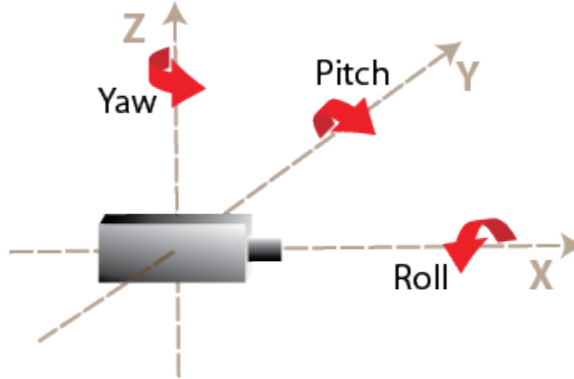

## Spatial Coordinate System

Spatial coordinates enable you to specify a location in an image with greater granularity than pixel coordinates. In the pixel coordinate system, each pixel is treated as a discrete unit, uniquely identified by an integer row and column pair, such as (3,4). In the spatial coordinate system, locations in an image are represented in terms of partial pixels, such as (3.3,4.7).

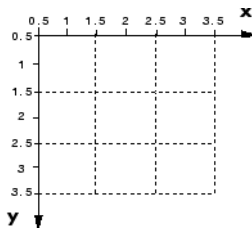

For more information on the spatial coordinate system, see “Spatial Coordinates”.

## Pattern Coordinate System

A common technique for estimating the parameters of a monocular camera sensor is to calibrate the camera using multiple images of a calibration pattern, such as a checkerboard. In the pattern coordinate system,  $(X_P, Y_P)$ , the  $X_P$ -axis points to the right and the  $Y_P$ -axis points down. The checkerboard origin is the bottom-right corner of the top-left square of the checkerboard.

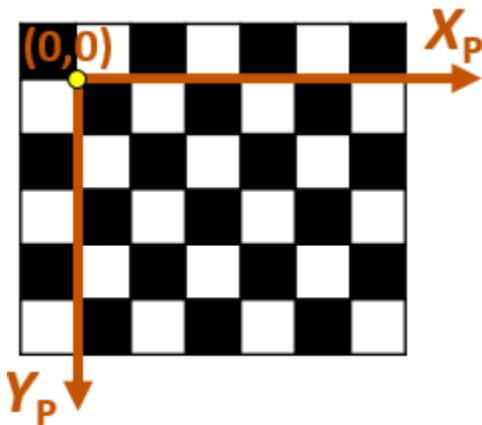

Each checker corner represents one point in the coordinate system. For example, the corner to the right of the origin is (1,0) and the corner below the origin is (0,1). For more information on calibrating a camera by using a checkerboard pattern, see “Calibrate a Monocular Camera” (Automated Driving Toolbox).

## **See Also**

### **More About**

- “Coordinate Systems”
- “Image Coordinate Systems”

## What Is Lidar-Camera Calibration?

Lidar-camera calibration establishes correspondences between 3-D lidar points and 2-D camera data to fuse the lidar and camera outputs together.

Lidar sensors and cameras are widely used together for 3-D scene reconstruction in applications such as autonomous driving, robotics, and navigation. While a lidar sensor captures the 3-D structural information of an environment, a camera captures the color, texture, and appearance information. The lidar sensor and camera each capture data with respect to their own coordinate system.

Lidar-camera calibration consists of converting the data from a lidar sensor and a camera into the same coordinate system. This enables you to fuse the data from both sensors and accurately identify objects in a scene. This figure shows the fused data.

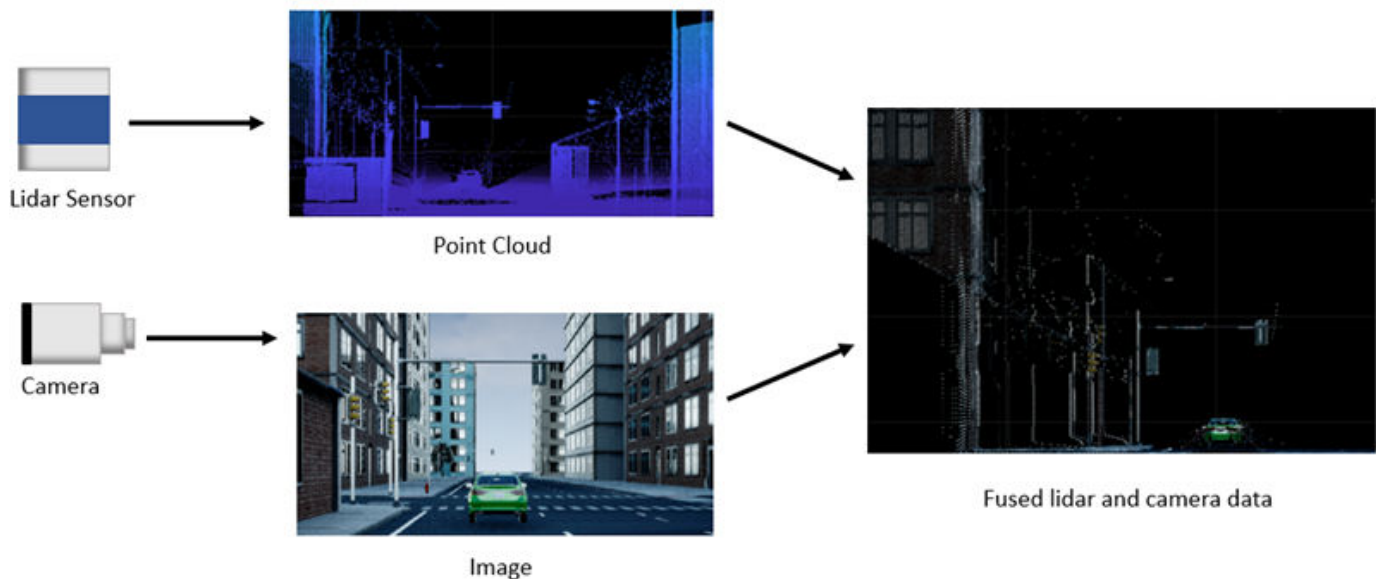

Lidar-camera calibration consists of intrinsic calibration and extrinsic calibration.

- Intrinsic calibration — Estimate the internal parameters of the lidar sensor and camera.
  - Manufacturers calibrate the intrinsic parameters of their lidar sensors in advance.
  - You can use the `estimateCameraParameters` function to estimate the intrinsic parameters of the camera, such as focal length, lens distortion, and skew. For more information, see the “Single Camera Calibration” example.
  - You can also interactively estimate camera parameters using the **Camera Calibrator** app.
- Extrinsic calibration — Estimate the external parameters of the lidar sensor and camera, such as location, orientation, to establish relative rotation and translation between the sensors.

### Extrinsic Calibration of Lidar and Camera

The extrinsic calibration of a lidar sensor and camera estimates a rigid transformation between them that establishes a geometric relationship between their coordinate systems. This process uses standard calibration objects, such as planar boards with checkerboard patterns.

This diagram shows the extrinsic calibration process for a lidar sensor and camera using a checkerboard.

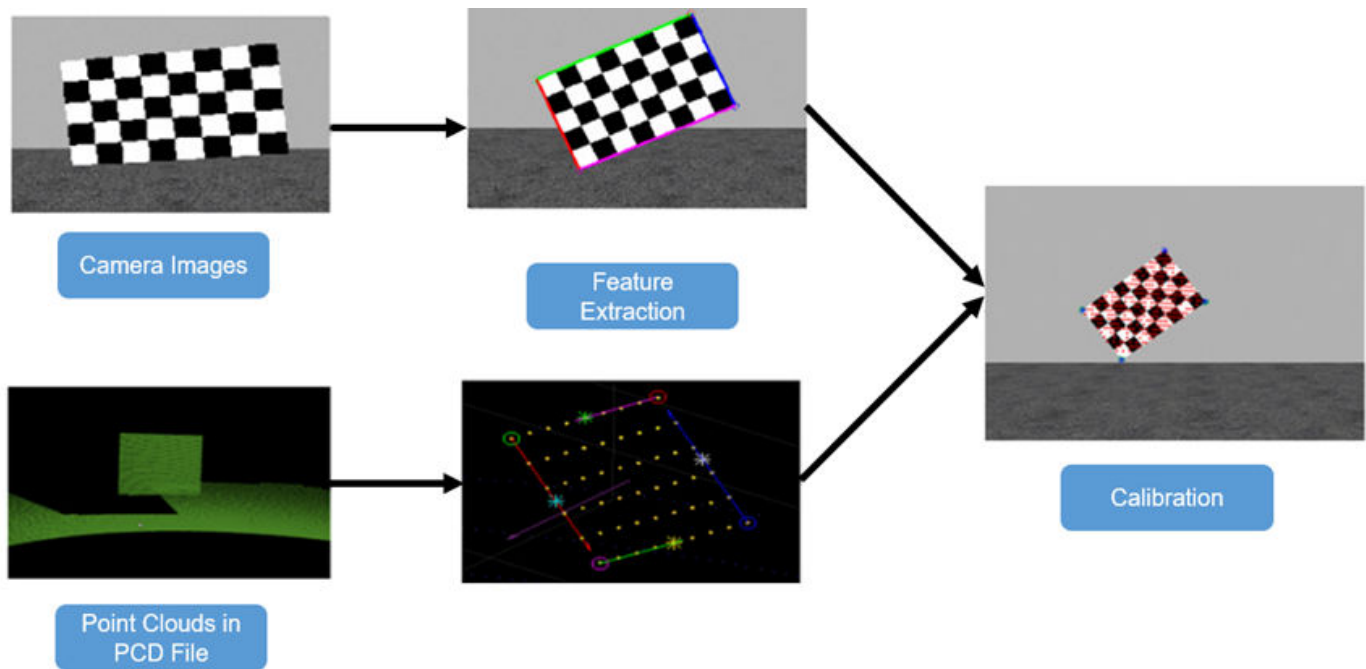

The programmatic workflow for extrinsic calibration consists of these steps. Alternatively, you can use the **Lidar Camera Calibrator** app to interactively perform lidar-camera calibration.

- 1 Extract the 3-D information of the checkerboard from both the camera and lidar sensor.
  - a To extract the 3-D checkerboard corners from the camera data, in world coordinates, use the `estimateCheckerboardCorners3d` function.
  - b To extract the checkerboard plane from the lidar point cloud data, use the `detectRectangularPlanePoints` function.
- 2 Use the checkerboard corners and planes to obtain the rigid transformation matrix, which consists of the rotation  $R$  and translation  $t$ . You can estimate the rigid transformation matrix by using the `estimateLidarCameraTransform` function. The function returns the transformation as a `rigid3d` object.

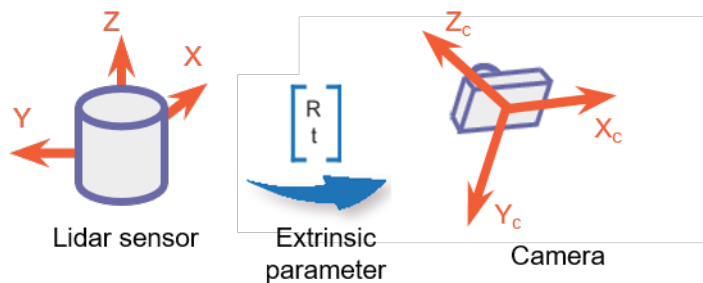

You can use the transformation matrix to:

- Evaluate the accuracy of your calibration by calculating the error. You can do so either programmatically, using `estimateLidarCameraTransform`, or interactively, using the **Lidar Camera Calibrator** app.
- Project lidar points onto an image by using the `projectLidarPointsOnImage` function, as shown in this figure.



- Fuse the lidar and camera outputs by using the `fuseCameraToLidar` function.
- Estimate the 3-D bounding boxes in a point cloud based on the 2-D bounding boxes in the corresponding image. For more information, see “Detect Vehicles in Lidar Using Image Labels” on page 1-163.



Bounding boxes in image

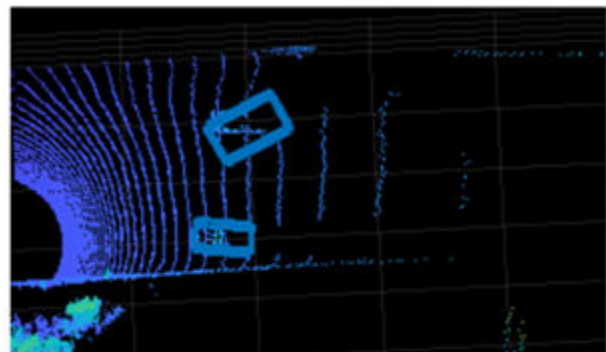

Detected bounding boxes in point cloud  
(Top view)

## References

- [1] Zhou, Lipu, Zimo Li, and Michael Kaess. “Automatic Extrinsic Calibration of a Camera and a 3D LiDAR Using Line and Plane Correspondences.” In *2018 IEEE/RSJ International Conference on Intelligent Robots and Systems (IROS)*, 5562–69. Madrid: IEEE, 2018. <https://doi.org/10.1109/IROS.2018.8593660>.

## See Also

[estimateLidarCameraTransform](#) | [estimateCheckerboardCorners3d](#) | [detectRectangularPlanePoints](#) | [projectLidarPointsOnImage](#) | [fuseCameraToLidar](#) | [bboxCameraToLidar](#)

## Related Examples

- “Lidar and Camera Calibration” on page 1-119
- “Detect Vehicles in Lidar Using Image Labels” on page 1-163

## More About

- “Calibration Guidelines” on page 4-14
- “Coordinate Systems in Lidar Toolbox” on page 4-7
- “Get Started with Lidar Camera Calibrator” on page 4-21

## Calibration Guidelines

These guidelines can help you achieve accurate results for lidar-camera calibration. For more information on lidar-camera calibration, see “What Is Lidar-Camera Calibration?” on page 4-10

### Checkerboard Guidelines

- When using the checkerboard function to create a checkerboard image:
  - Create a rectangular checkerboard that contains an even number of squares along one edge and an odd number of squares along the adjacent edge. This ensures a pattern with two black corners and two white corners. Patterns in which all corners are the same color can produce unexpected results for camera extrinsic parameters.
  - You can use the length differences of sides and the different corner colors to determine the orientation and the origin of the checkerboard. The **Lidar Camera Calibrator** app assigns the x-direction to the longer side of the checkerboard.
- Print the checkerboard from end-to-end on a foam board, as shown in this figure, to avoid any measurement errors.

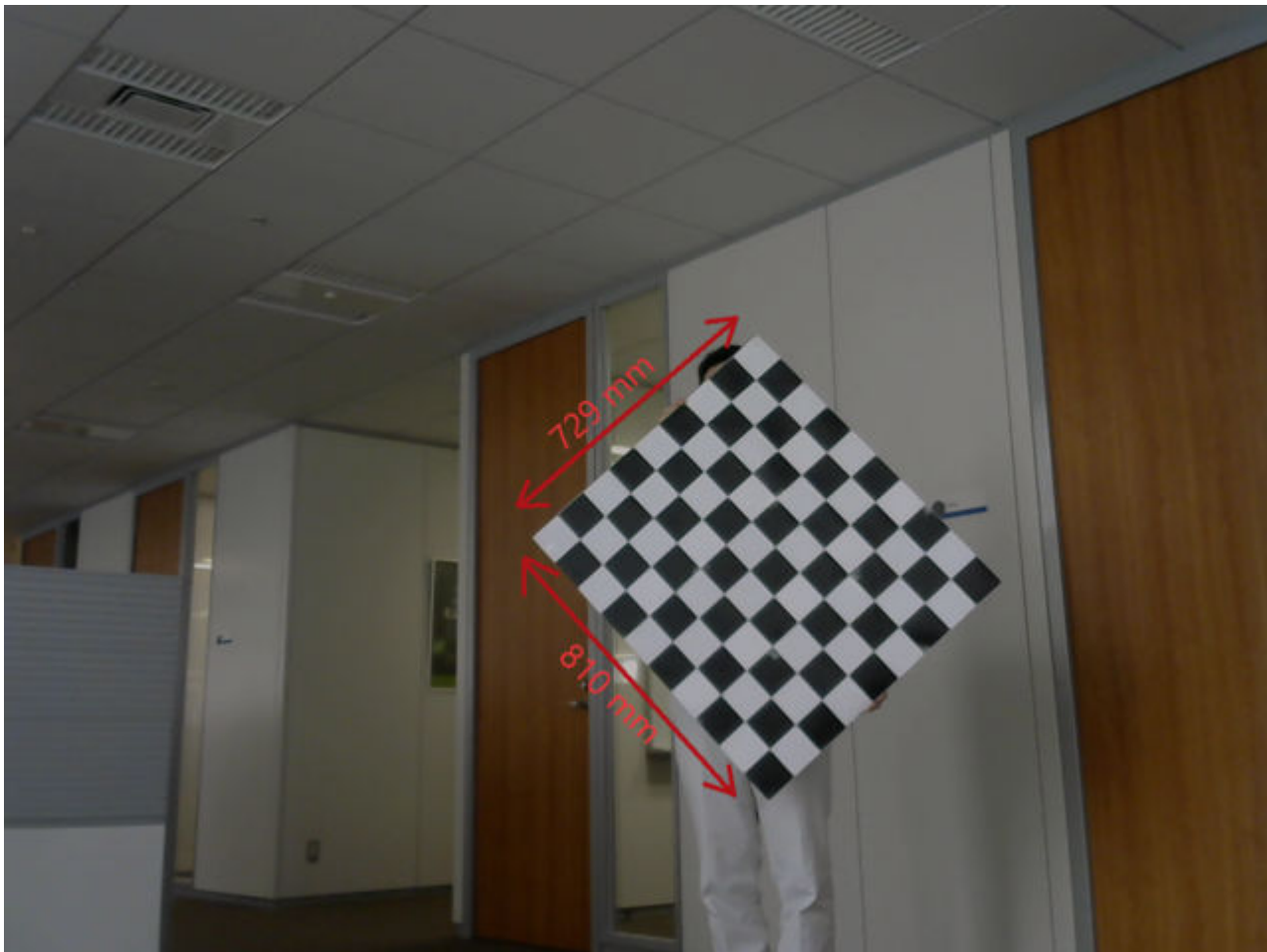

- Accurately measure any padding you add along each side of the checkerboard. Padding values must be specified as a vector to the **Lidar Camera Calibrator** app or



`estimateCheckerboardCorners3d` function when you estimate the checkerboard corners. This figure shows the order of elements of the padding vector, clockwise from the left side of the checkerboard.

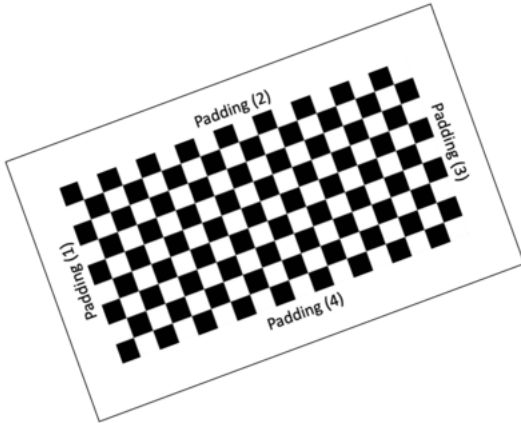

### Checkerboard Padding

## Guidelines for Capturing Data

- Capture data from both sensors simultaneously with no motion blur effects. Motion blur can degrade the accuracy of the calibration. If you are working with a video recording, carefully capture the point clouds corresponding to the respective image frames.
- The checkerboard should point towards the front axes of the camera ( $z$ -axis) and lidar sensor ( $x$ -axis).
- Hold the checkerboard target with your arms fully extended, rather than close to your body. Otherwise, parts of your body may appear to be planar with the target. This can cause inaccurate checkerboard detection.
- For sparse lidar sensors, hold the target from behind, rather than on the edges, because the `detectRectangularPlanePoints` function searches for the checkerboard plane in each cluster of the input point cloud. To further reduce false detections, specify the approximate checkerboard position using the “ROI” name-value argument.
- Be aware of the viewing angle or the field of view of the lidar sensor. Do not place the board in the blindspots of the sensor.
- Pay close attention to the distance between the sensor and the checkerboard. Low resolution lidar sensors, such as the Velodyne VLP-16, can have trouble accurately detecting distant checkerboards.
- Remove other items from the checkerboard plane to avoid clustering them with the checkerboard data.
- For high-resolution lidar sensors like the HDL-64 and Ouster OS1-64, you can hold the checkerboard horizontally or vertically while capturing data. However, for best results, tilt the checkerboard to a 45-degree angle while capturing data.
- This figure shows different ways to hold the checkerboard while capturing data. Capture at least 10 frames for accurate calibration.
- You must save point cloud data in the PCD or PLY format.

- Image files can be in any standard image format supported by MATLAB.

For more details on the calibration workflow, see the “Lidar and Camera Calibration” on page 1-119 example.

### See Also

**Lidar Camera Calibrator** | `estimateLidarCameraTransform` | `estimateCheckerboardCorners3d` | `detectRectangularPlanePoints` | `projectLidarPointsOnImage` | `fuseCameraToLidar`

### Related Examples

- “Lidar and Camera Calibration” on page 1-119
- “Detect Vehicles in Lidar Using Image Labels” on page 1-163

### More About

- “What Is Lidar-Camera Calibration?” on page 4-10
- “Get Started with Lidar Camera Calibrator” on page 4-21
- “Coordinate Systems in Lidar Toolbox” on page 4-7

# What are Organized and Unorganized Point Clouds?

## Introduction

There are two types of point clouds: organized and unorganized. These describe point cloud data stored in a structured manner or in an arbitrary fashion, respectively. An organized point cloud resembles a 2-D matrix, with its data divided into rows and columns. The data is divided according to the spatial relationships between the points. As a result, the memory layout of an organized point cloud relates to the spatial layout represented by the  $xyz$ -coordinates of its points. In contrast, unorganized point clouds consist of a single stream of 3-D coordinates, each coordinate representing a single point. You can also differentiate these point clouds based on the shape of their data. Organized point clouds are  $M$ -by- $N$ -by-3 arrays, with the three channels representing the  $x$ -,  $y$ -, and  $z$ -coordinates of the points. Unorganized point clouds are  $M$ -by-3 matrices, where  $M$  is the total number of points in the point cloud.

## Unorganized to Organized Conversion

Most deep learning segmentation networks, such as SqueezeSegv1/v2, RangeNet++, and SalsaNext, process only organized point clouds. In addition, organized point clouds are used in ground plane extraction and key point detection methods. This makes organized point cloud conversion an important preprocessing step for many Lidar Toolbox workflows.

You can convert unorganized point clouds to organized point clouds by using the `pcorganize` function. The underlying algorithm uses spherical projection to represent the 3-D point cloud data in a 2-D (organized) form. It requires certain corresponding lidar sensor parameters, specified using the `LidarParameters` object, in order to convert the data.

### Lidar Sensor Parameters

The sensor parameters required for conversion differ based on whether the lidar sensor has a uniform beam or a gradient beam configuration. A lidar sensor is created by stacking laser scanners vertically. Each laser scanner releases a laser pulse and rotates to capture a 3-D point cloud.

When the laser scanners are stacked with equal spacing, the lidar sensor has a uniform beam (laser scanner) configuration.

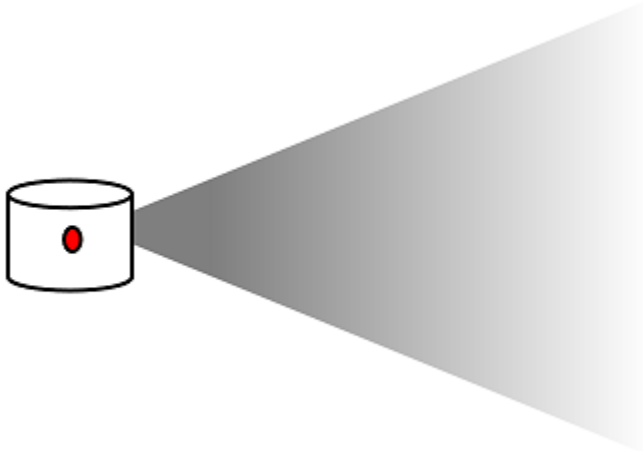

To convert unorganized point clouds captured using a lidar sensor with a uniform beam configuration, you must specify these parameters from the sensor handbook:

- Vertical resolution — Number of channels in the vertical direction, consisting of the number of lasers. Typical values include 32 and 64.
- Horizontal resolution — Number of channels in the horizontal direction. Typical values include 512 and 1024.
- Vertical field of view — Vertical field of view, in degrees. The sensor in the preceding picture has a vertical field of view of 45 degrees.

For an example, see “Create a Lidar Parameters Object”.

When the beams at the horizon are tightly packed, and those toward the top and bottom of the sensor field of view are more spaced out, the lidar sensor has a gradient beam configuration.

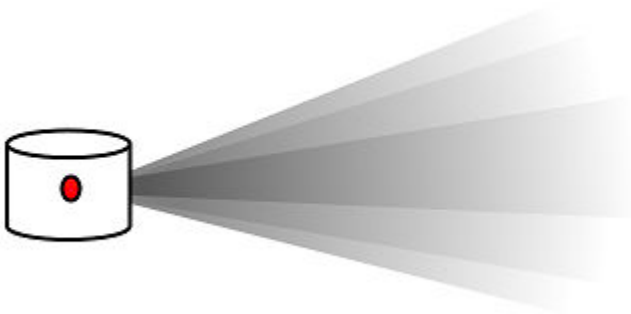

To convert unorganized point clouds captured using a lidar sensor with a gradient beam configuration, you must specify these parameters from the sensor handbook:

- Horizontal resolution — Number of channels in the horizontal direction. Typical values include 512 and 1024.
- Vertical beam angles — Angular position of each vertical channel, in degrees.

For an example, see “Create Lidar Parameters Object for Gradient Lidar Sensor”.

### Supported Sensors

The `LidarParameters` object can automatically load the sensor parameters for some popular lidar sensors. These sensors are supported:

Sensor Name	Input
Velodyne HDL-64E	'HDL64E '
Velodyne HDL-32E	'HDL32E '
Velodyne VLP16	'VLP16 '
Velodyne VLP32C	'VLP32C '
Velodyne VLP128	'VLS128 '
Velodyne Puck LITE	'PuckLITE '
Velodyne Puck Hi-Res	'PuckHiRes '

Sensor Name	Input
Ouster OS0-32	OS0 - 32
Ouster OS0-64	OS0 - 64
Ouster OS0-128	OS0 - 128
Ouster OS1Gen1-32	OS1Gen1 - 32
Ouster OS1Gen1-64	OS1Gen1 - 64
Ouster OS1Gen1-128	OS1Gen1 - 128
Ouster OS1Gen2-32	OS1Gen2 - 32
Ouster OS1Gen2-64	OS1Gen2 - 64
Ouster OS1Gen2-128	OS1Gen2 - 128
Ouster OS2-32	OS2 - 32
Ouster OS2-64	OS2 - 64
Ouster OS2-128	OS2 - 128

## See Also

`pcorganize` | `lidarParameters`

## Related Examples

- “Unorganized to Organized Conversion of Point Clouds Using Spherical Projection” on page 1-265

## Parameter Tuning for Ground Segmentation

The `segmentGroundSMRF` function segments ground points in a point cloud. The function parameters need to be tuned in order to get accurate results based on the data. This page will explain the significance of the function parameters and how it can be tuned for aerial and driving scenario point clouds. By default, the function is tuned for aerial point cloud data.

The meaning of each parameter and the underlying are explained in the `segmentGroundSMRF` documentation. The effect of each parameter on the data is explained in the following list:

### See Also

# Get Started with Lidar Camera Calibrator

The **Lidar Camera Calibrator** app enables you to interactively estimate the rigid transformation between a lidar sensor and a camera.

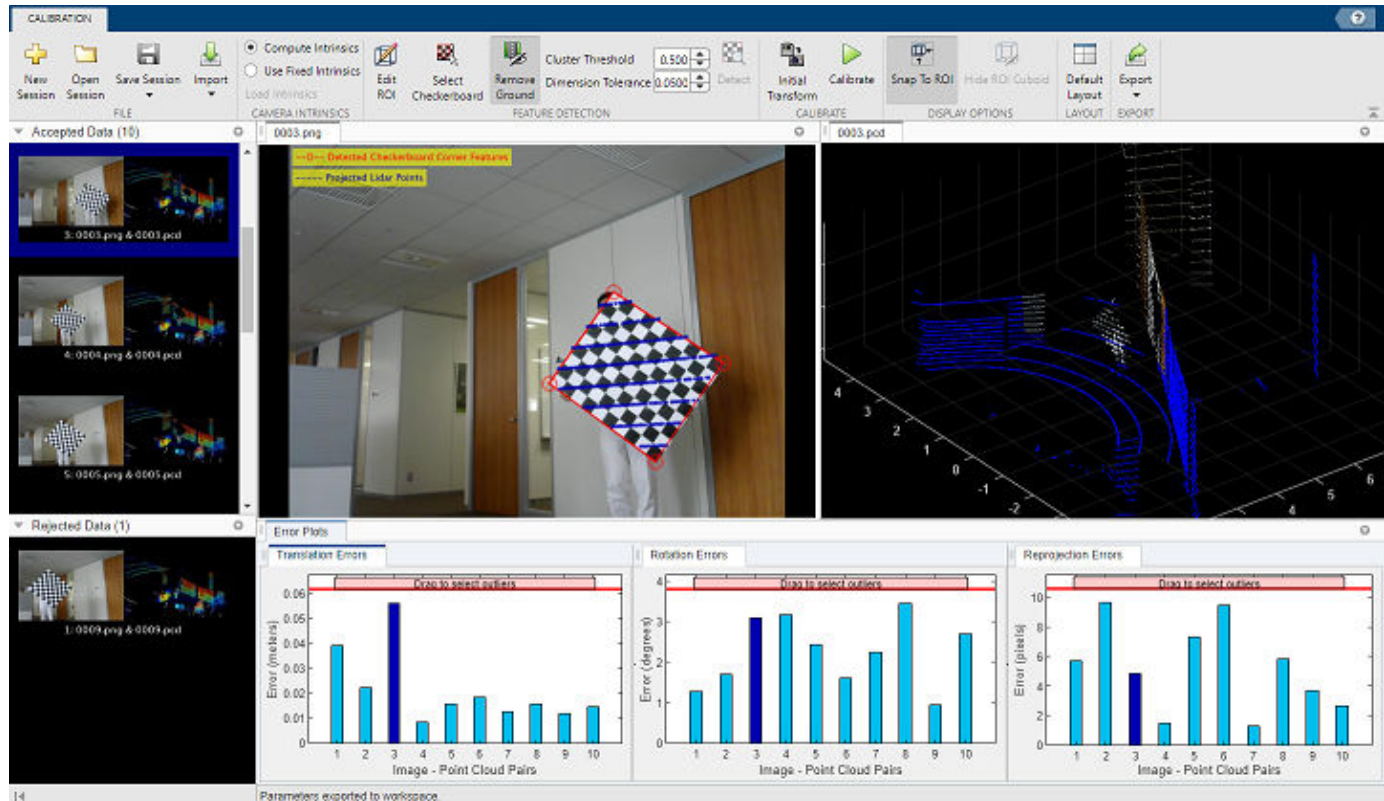

This topic shows you the **Lidar Camera Calibrator** app workflow, as well as features you can use, to analyze and improve your results. The first, and most important, part of the calibration process is to obtain accurate and useful data. For guidelines and tips for capturing data, see “Calibration Guidelines” on page 4-14.

## Load Data

To open the **Lidar Camera Calibrator** app, at the MATLAB command prompt, enter this command.

```
lidarCameraCalibrator
```

Alternatively, you can open the app from the **Apps** tab, under **Image Processing and Computer Vision**.

The app opens to an empty session. The app reads point cloud data in the PLY and point cloud data (PCD) formats, and images in any format supported by `imformats`. If your data is stored in a rosbag file, see the “Read Lidar and Camera Data from Rosbag File” on page 5-13 tutorial to convert it accordingly.

Load the calibration data into the app.

- 1 On the app toolstrip, select **Import > Import Data**, opening the **Import Data** dialog box.
- 2 In the **Folder for images** box, enter the path to the folder that contains the image files you want to load. Alternatively, select the **Browse** button next to the box, navigate to the folder containing the images, and click **Select Folder**.
- 3 In the **Folder for point clouds** box, enter the path to the folder that contains the sequence of PCD or PLY files you want to load. Alternatively, select the **Browse** button next to the box, navigate to the folder containing the files, and click **Select Folder**.
- 4 In the **Checkerboard Settings** section, enter the calibration checkerboard parameters. Specify the size for each checkerboard square in the **Square Size** box, and select the units of measurement from the list next to the box.
- 5 In the **Padding** box, enter the padding values for the checkerboard. For more information on padding, see “Checkerboard Padding” on page 4-14. Click **OK** to import your data.

To add more images and point clouds to the session at any point in the session, select **Import > Add Data to Session**.

## Feature Detection

The app loads the image and point cloud data and performs an automatic feature detection pass on the data using the specified checkerboard parameters. It detects the checkerboard corners from the image data and the checkerboard plane from the point cloud data. The app interface displays the detection progression and results.

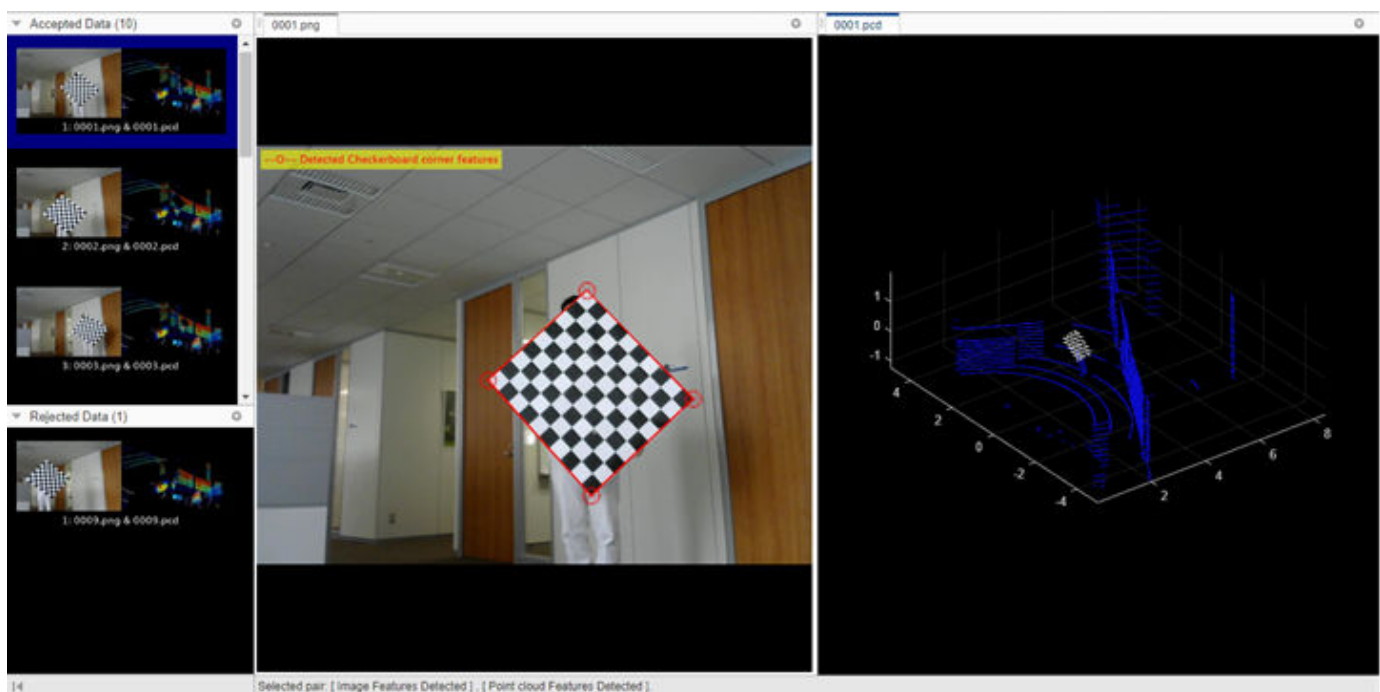

The **Accepted Data** pane displays the image and point cloud pairs that the app accepts for calibration. The app accepts an image or point cloud if it detects checkerboard features in both of them. The app uses file names to pair the image and point cloud data. It compares images to the corresponding point clouds with the same file name. The **Rejected Data** pane displays the data pairs for which the app could not detect features in the image, the point cloud, or both. You can use “Select



Region of Interest” on page 4-24 or “Select Checkerboard Region” on page 4-25 on the **Rejected Data** to obtain better detections.

The app displays the data in the visualization area as separate panes for image and point cloud data. Each pane has tabs with the image or point cloud data file name. You can select a data pair from the **Accepted Data** or **Rejected Data** pane to visualize it in this area. When you select a data pair is selected, the app highlights it in blue. To delete the selected data pair, press **Backspace** (PC) or **delete** (Mac). For more keyboard shortcuts for the data browser, see “Data Browser” on page 4-29.



The image display pane shows the image from the selected pair and the detected checkerboard corners. To detect the checkerboard corners, the app uses the `estimateCheckerboardCorners3d` function. The app computes camera intrinsics to perform feature detection. If you have camera intrinsic values, you can load them into the app, in the **Camera Intrinsic** section, by selecting **Use Fixed Intrinsic**. In the dialog box that opens, browse to your camera intrinsics file and load it into the app. After loading, in the **Feature Detection** section, select **Detect** to detect features with the new intrinsics.

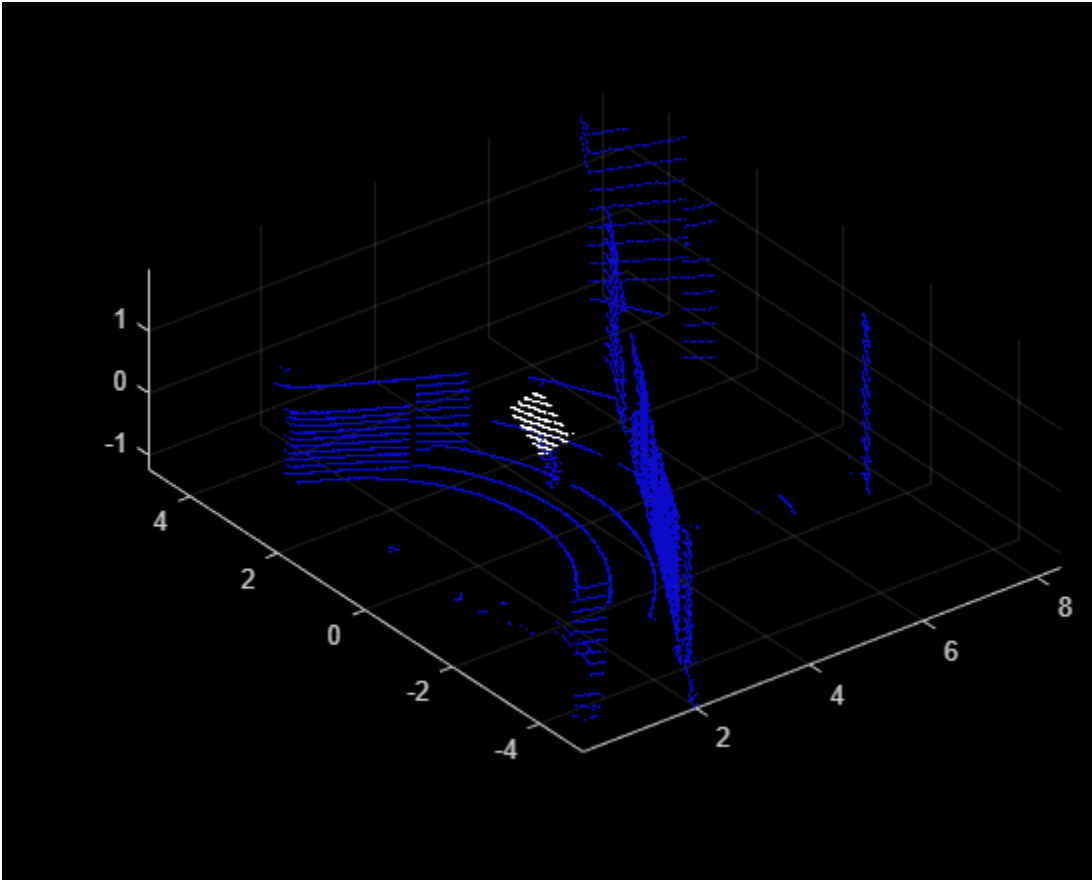

The point cloud display pane shows the point cloud from the selected pair, with the detected checkerboard plane rendered in white. To detect the plane, the app uses the `detectRectangularPlanePoints` function.

Use the various display options for point clouds in the app to improve visualization and detection.

### Select Region of Interest

Select **Snap To ROI** to visualize a particular region of interest (ROI) in the point cloud. The app sets a default value for the ROI, but you can set a custom ROI using the **Edit ROI** tool. This tool enables you to manually pinpoint the region of the point cloud. Specifying an ROI to the region where the checkerboard is present can reduce data rejections and improve performance by focusing feature detection on a specific region.

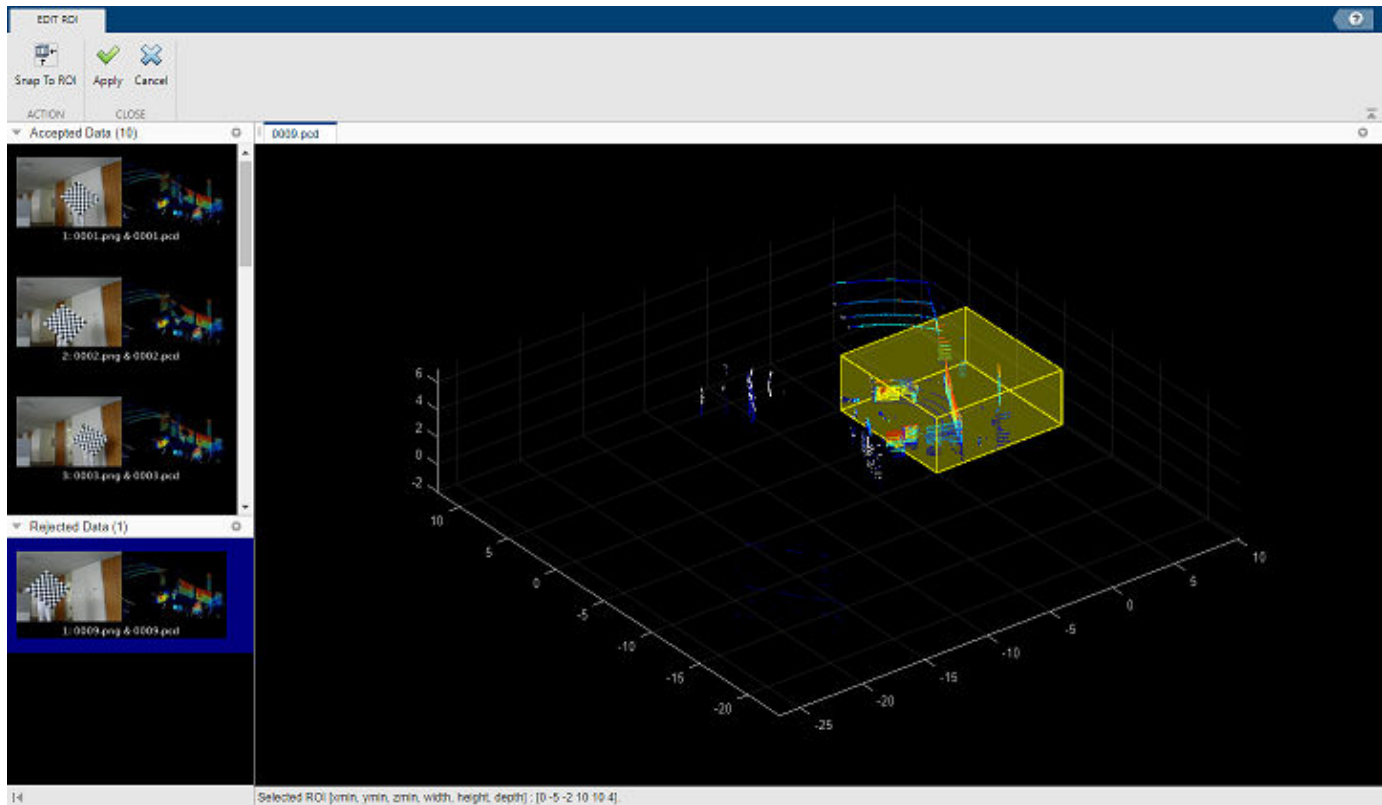

- 1 Select **Edit ROI**, which opens the **Edit ROI** tab. The tab contains the same **Accepted Data** and **Rejected Data** panes as the **Calibration** tab, but the point cloud display pane takes up the rest of the window.
- 2 Select a data pair, which the app highlights in blue. You can select a rejected data pair to tune the ROI.
- 3 Clear the **Snap To ROI** button to view the whole point cloud.
- 4 The ROI is highlighted in yellow. Point to the ROI, and the cursor turns into a hand symbol.
- 5 Click on any side of the ROI and drag it to toggle the size. You can select **Snap To ROI** to view the contents of the ROI and change the size accordingly.
- 6 Select **Apply** to save your changes or **Cancel** to discard them.

Because the app applies the new ROI on all the point cloud frames, you must define an ROI that covers all areas in which you placed the checkerboard. Clear the **Snap To ROI** button to view the whole point cloud and select the **Hide ROI Cuboid** to remove the ROI highlighting. Select **Detect** to detect features in the selected ROI. Alternatively, you can use keyboard shortcuts to perform these tasks. For more information, see “Edit ROI” on page 4-30.

### Select Checkerboard Region

To further tune the detections, you can use the **Select Checkerboard** feature to manually select checkerboard points in any point cloud frame.

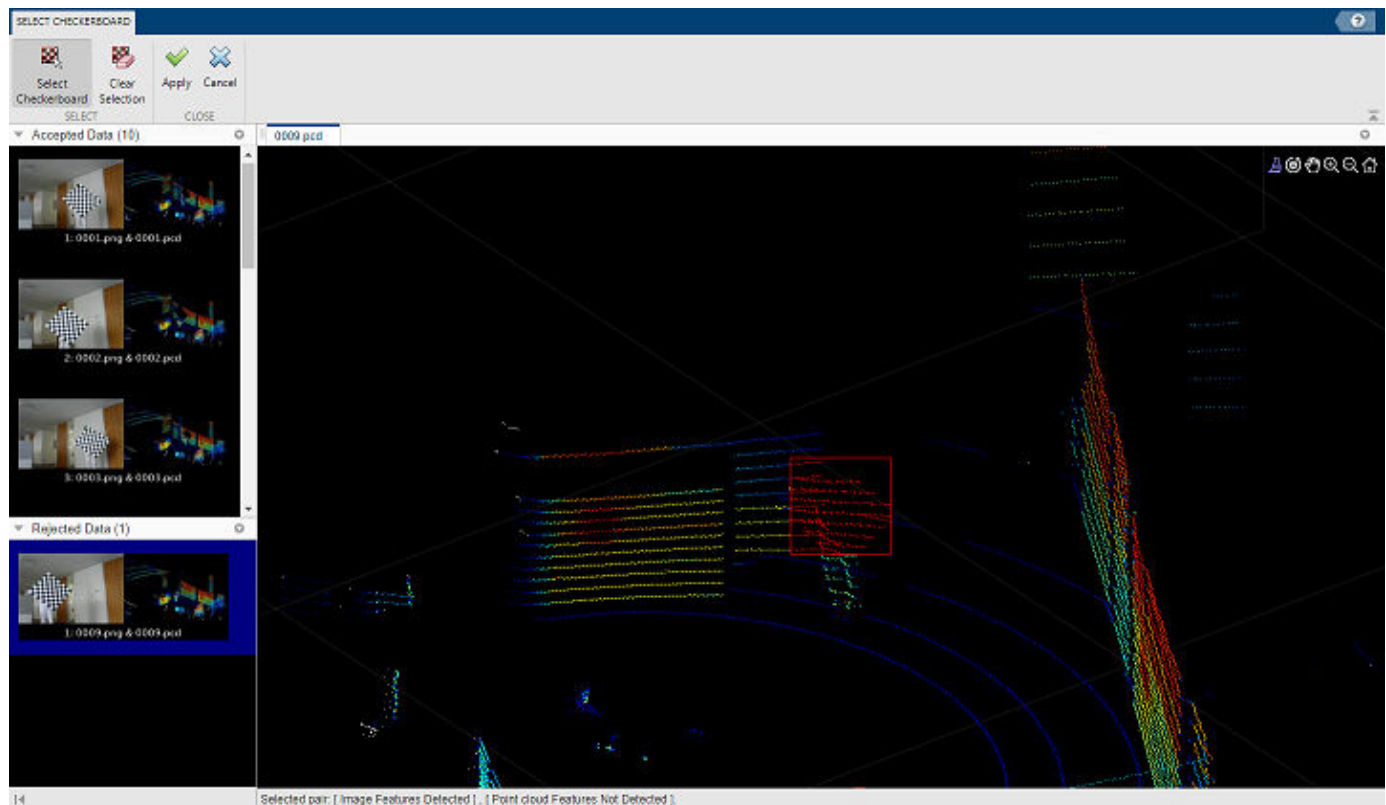

- 1 On the app toolbar, select **Select Checkerboard**. The app opens the **Select Checkerboard** tab. This tab contains the same **Accepted Data** and **Rejected Data** panes as the **Calibration** tab, but the point cloud display pane takes up the rest of the window.
- 2 Select a data pair. The app highlights it in blue. You can select a rejected data pair and find the checkerboard in the point cloud.
- 3 Use the zoom and rotate options in the axes toolbar of the point cloud display to locate the checkerboard.
- 4 Select **Select Checkerboard**. The cursor changes into a crosshair.
- 5 Click and drag the cursor over the checkerboard. A selection rectangle appears, with the points inside it highlighted in red. Alternatively, you can also select **Brush/Select Data** on the axes toolbar.
- 6 After selecting the points, rotate the point cloud to check whether any background points have been selected. If your selection contains unwanted points, select **Clear Selection** to start over.
- 7 Select **Apply** to save the selected points, or **Cancel** to discard them.

This checkerboard selection applies only to the current point cloud. Select **Detect** to detect features using the manually selected checkerboard.

### Feature Detection Settings

The app provides these feature detection settings in which you can tune parameters.

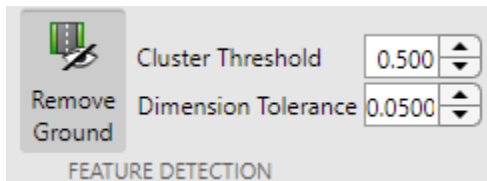

- **Remove Ground** — Remove ground points from the point cloud. The app uses the `pcfitplane` function to estimate the ground plane. The **Remove Ground** feature is enabled by default. Select **Remove Ground** to clear it.
- **Cluster Threshold** — Clustering threshold for two adjacent points in the point cloud, specified in meters. The clustering process is based on the Euclidean distance between adjacent points. If the distance between two adjacent points is less than the clustering threshold, both points belong to the same cluster. Low-resolution lidar sensors require a higher **Cluster Threshold**, while high-resolution lidar sensors benefit from a lower **Cluster Threshold**.
- **Dimension Tolerance** — Tolerance for uncertainty in the rectangular plane dimensions, specified in the range  $[0,1]$ . A higher **Dimension Tolerance** indicates a more tolerant range for the rectangular plane dimensions.

Select **Detect** to detect features using the new parameters.

## Calibration

When you are satisfied with the detection results, select **Calibrate** button to calibrate the sensors. If you have an estimated transformation matrix, select **Initial Transform** to load the transformation matrix from a file or the workspace. The app assumes the rotation angle between the lidar sensor and the camera is in the range  $[-45\ 45]$ , in degrees, along each axis. For a rotation angle outside this range, use **Initial Transform** to specify an initial transformation to improve calibration accuracy.

After calibration, the app interface displays the image with the checkerboard points from the point cloud projected onto it. The app uses the `projectLidarPointsOnImage` function to project the lidar points onto the image. The color information of the images is fused with the point cloud data using the `fuseCameraToLidar` function.

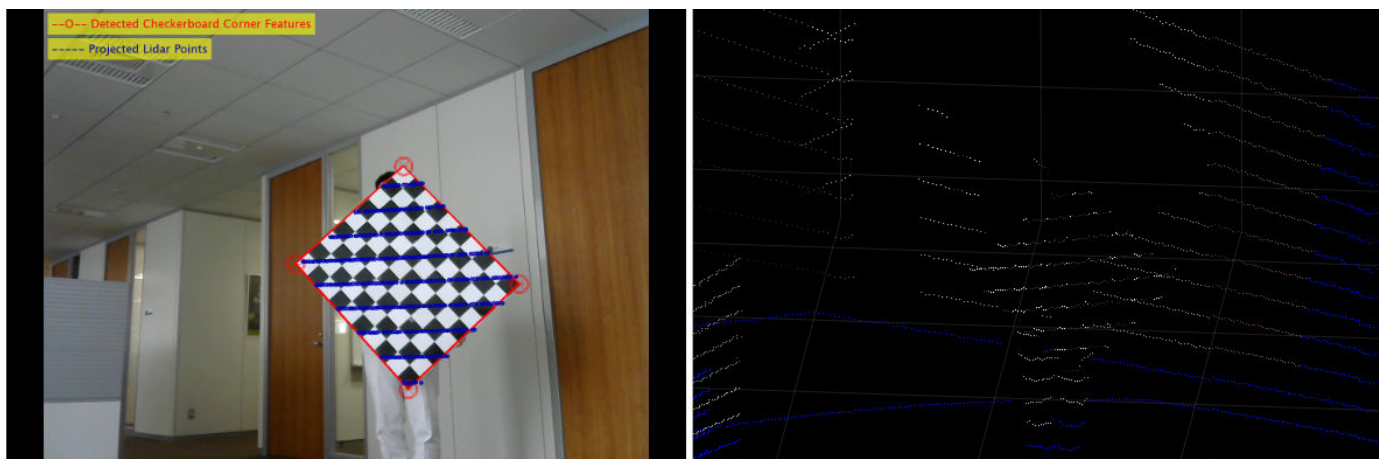

The app also provides the inaccuracy metrics for the transformation matrix using error plots. The plots specify these errors in each data pair:

- **Translation Errors** — The difference between the centroid coordinates of the checkerboard planes in the point clouds and those in the corresponding images. The app returns the error values in meters.
- **Rotation Errors** — The difference between the normal angles defined by the checkerboard planes in the point clouds and those in the corresponding images. The app estimates the plane in the image using the checkerboard corner coordinates. The app returns the error values in degrees.
- **Reprojection Error**— The difference between the projected (transformed) centroid coordinates of the checkerboard planes from the point clouds and those in the corresponding images. The app returns the error values in pixels.

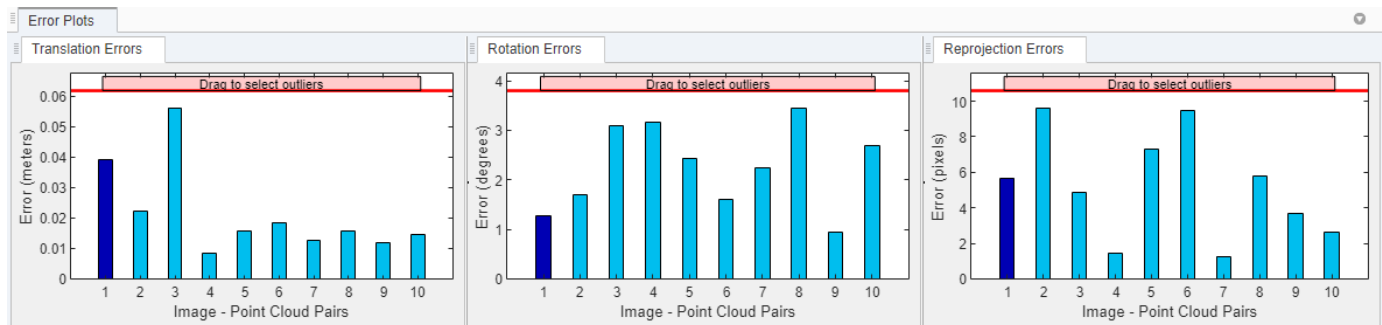

When you select a data pair in the data browser, the corresponding bars in the error plot are highlighted in dark blue. You can tune the calibration results by removing outliers. Drag the red line on each plot vertically to set error limits. The app selects all the data pairs with an error value greater than error limit as outliers, and highlights the error bars and their corresponding data pairs in the data browser in blue. Right-click any of the selected data pairs on the data browser and select **Remove and Recalibrate** to delete the outliers and recalibrate the sensors. Deleting outliers can improve calibration accuracy. For a list of keyboard shortcuts to use with the error plots, see “Error Plots” on page 4-29.

## Export Results

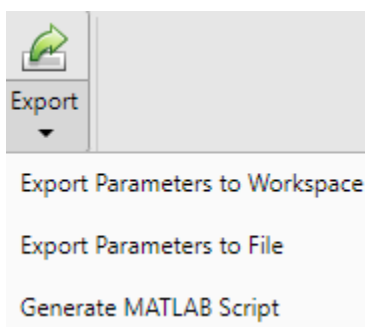

You can export the transformation matrix and error metrics, as variables, into the workspace or a MAT-file. You can generate a MATLAB script of the complete app workflow to use in your projects.

## Keyboard Shortcuts and Mouse Actions

**Note** On Macintosh platforms, use the **Command (⌘)** key instead of **Ctrl**.

Use keyboard shortcuts and mouse actions to increase productivity while using the **Lidar Camera Calibrator** app.

### Data Browser

Task	Action
Navigate through data pairs in the <b>Accepted Data</b> or <b>Rejected Data</b> pane	Up or down arrow
Select all data pairs in the data browser	<b>Ctrl+A</b>
Select multiple data pairs above or below the currently selected data pair.	Hold <b>Shift</b> and press the up arrow or down arrow
Select multiple data pairs.	Hold <b>Ctrl</b> and click on data pairs
<b>Note</b> Deselecting a selected data pair is not currently supported using the same shortcut.	
Delete the selected data pair from the data browser.	<ul style="list-style-type: none"> <li>PC: <b>Backspace</b> or <b>Delete</b></li> <li>Mac: <b>delete</b></li> </ul> A dialog box appears to deletion.
Select the data pair $N$ above the currently selected data pair. $N$ is the number of data pairs fully displayed in the data browser at the current time.	<ul style="list-style-type: none"> <li>PC: <b>Page Up</b></li> <li>Mac: Hold <b>Fn</b> and press the up arrow</li> </ul>
Select the data pair $N$ below the currently selected data pair. $N$ is the number of data pairs fully displayed in the data browser at the current time.	<ul style="list-style-type: none"> <li>PC: <b>Page Down</b></li> <li>Mac: Hold <b>Fn</b> and press the down arrow</li> </ul>
Select the first data pair in the data browser.	<ul style="list-style-type: none"> <li>PC: <b>Home</b></li> <li>Mac: Hold <b>Fn</b> and press the left arrow</li> </ul>
Select the last data pair in the data browser.	<ul style="list-style-type: none"> <li>PC: <b>End</b></li> <li>Mac: Hold <b>Fn</b> and press the right arrow</li> </ul>

### Error Plots

Use these shortcuts on the error plots to analyze the data. Operations on any of the three error plots affect the corresponding error bars on all three plots.

Task	Action
Select the error bar left of the currently selected error bar.	Left arrow
Select the error bar right of the currently selected error bar.	Right arrow
Select the error bar right or left of the currently selected error bar, in addition to the currently selected error bar.	Hold <b>Shift</b> and press the left arrow or right arrow



Task	Action
Select multiple error bars.	Hold <b>Ctrl</b> and click error bars
<b>Note</b> Deselecting a selected error bar is not currently supported using the same shortcut.	
Select all error bars.	<b>Ctrl+A</b>
Delete the selected error bar and corresponding data pair from the data browser. The app then recalibrates the sensors.	<ul style="list-style-type: none"> <li>• PC: <b>Backspace</b> or <b>Delete</b></li> <li>• Mac: <b>delete</b></li> </ul> <p>A dialog box appears to confirm deletion.</p>

### Edit ROI

Shortcuts to use on the **Edit ROI** tab.

Task	Action
Undo ROI size change.	<b>Ctrl+Z</b>
<b>Note</b> The app stores only the last three sizes of the ROI, so you cannot undo more than three times in a row.	
Redo ROI size change.	<b>Ctrl+Y</b>
Clear ROI selection	<b>Esc</b>

### Limitations

The **Lidar Camera Calibrator** app has these limitations:

- The script generated from **Export > Generate MATLAB Script** does not include any checkerboard regions manually selected using the **Select Checkerboard** feature. In the script, the checkerboard region is detected in the specified ROI.
- After manually selecting checkerboard regions using the **Select Checkerboard** feature, when you return to the **Calibration** tab, you can see the selected points (highlighted in red) only while viewing the whole point cloud ( when **SnapToROI** is cleared).

### See Also

**Lidar Camera Calibrator** | [estimateCheckerboardCorners3d](#) | [estimateLidarCameraTransform](#) | [projectLidarPointsOnImage](#) | [fuseCameraToLidar](#) | [bboxCameraToLidar](#)

### Related Examples

- “Lidar and Camera Calibration” on page 1-119
- “Read Lidar and Camera Data from Rosbag File” on page 5-13
- “Detect Vehicles in Lidar Using Image Labels” on page 1-163



## **More About**

- “What Is Lidar-Camera Calibration?” on page 4-10
- “Calibration Guidelines” on page 4-14

## Get Started with Lidar Viewer

Use the **Lidar Viewer** app to view, analyze, and perform preprocessing operations on lidar data. Use the app to prepare data for advanced workflows like labeling, segmentation, and calibration.

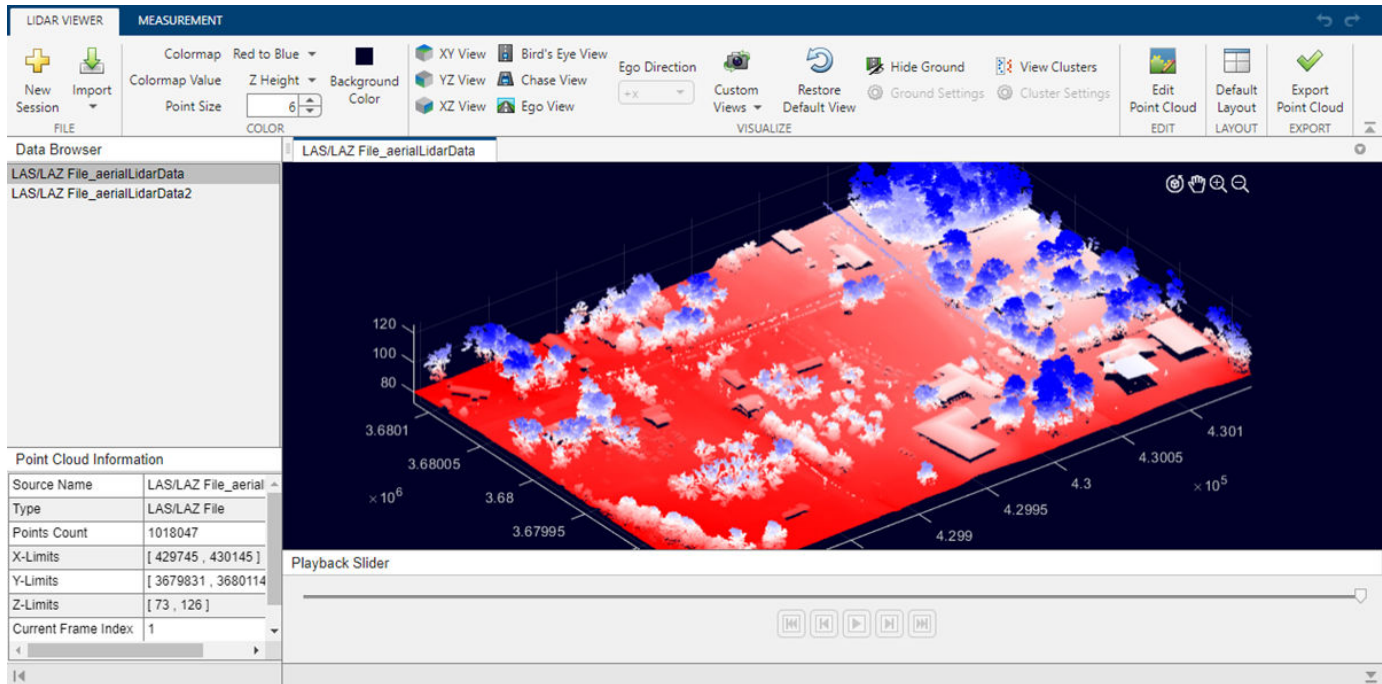

This topic provides an overview of the app workflow and underlying features. To open the app, at the MATLAB command prompt, enter this command.

```
lidarViewer
```

Alternatively, you can open the app from the **Apps** tab, under **Image Processing and Computer Vision**.

### Load Data

The **Lidar Viewer** app can import pointCloud objects from the workspace and read point cloud data from PLY, PCAP, LAS, LAZ, PCD, and rosbag files. You can load lidar data from multiple sources at once. Use this process to load data into the app:

- On the app toolbar, select **Import > From File**. Choose a data source from the list.
- In the **Import** dialog box that appears, specify the location of the point cloud data from the selected data source.
  - **Point Cloud Sequence** — In the **Provide path to a folder containing PCD/PLY file(s)** box, specify the path to the folder containing your point cloud data. Alternatively, select **Browse**, browse to the folder containing your data, and then select **Select Folder**.
  - **Velodyne Lidar** — For Velodyne lidar data, select the device model name from the **Device Model** list. In the **Provide path to a calibration file** box, specify the path to the calibration file of the sensor.

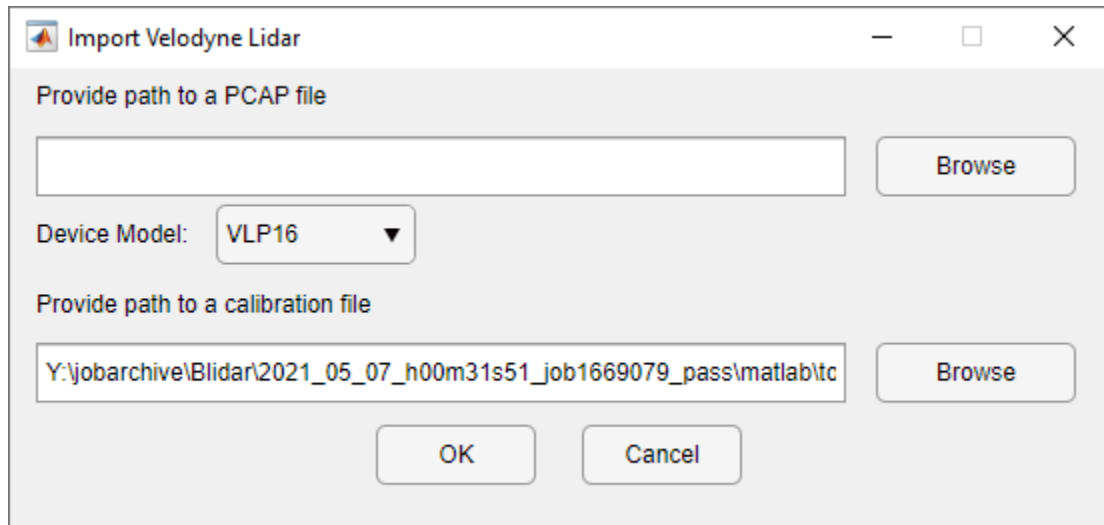

- **LAS/LAZ File**— In the **Provide path to a LAS/LAZ file** box, specify the path to the folder containing your point cloud data. Alternatively, select **Browse**, browse to the folder containing your data, and then select **Select Folder**.
- **Rosbag** — For rosbag files, select the topics that contain point cloud data from the **Point Cloud Topics** list. To load data from a rosbag file, you must have a ROS Toolbox license.

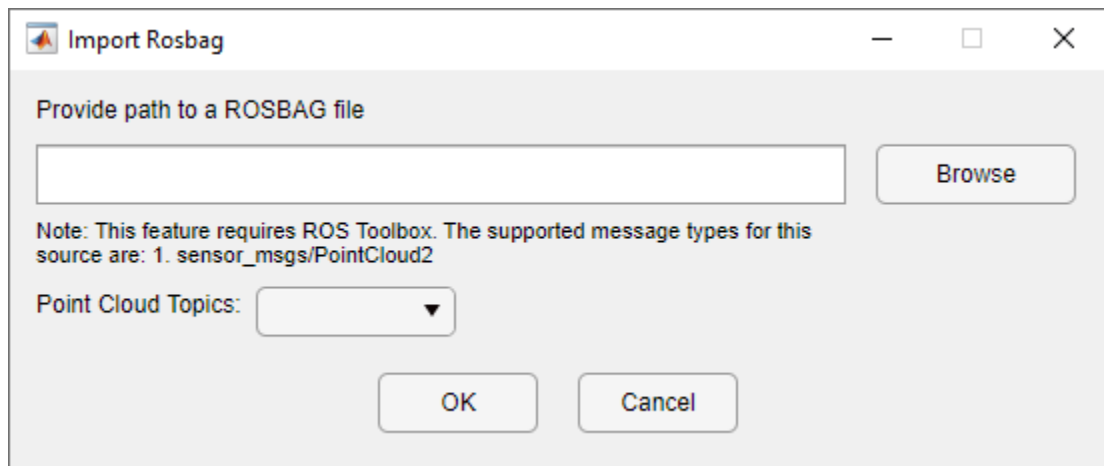

- **Custom Point Cloud** — To load point cloud data from a custom source, create a custom reader function and add it to your MATLAB path. In the **Custom Reader Function** box specify the path to the reader function, and in the **Source Name** box specify the path to the data folder.

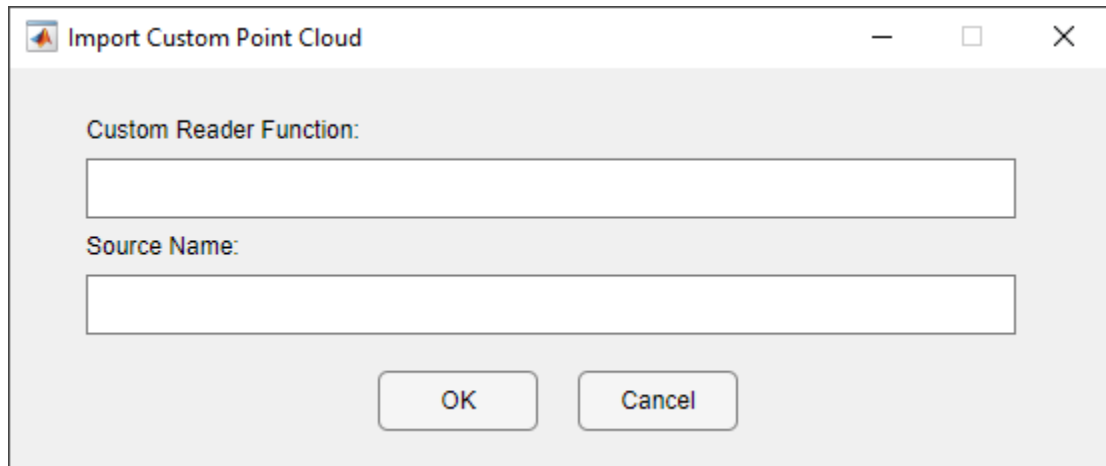

- Alternatively, select **Import > From Workspace** on the app toolbar. In the **Import From Workspace** dialog box that appears, select the variables/ objects from the workspace you want to import.

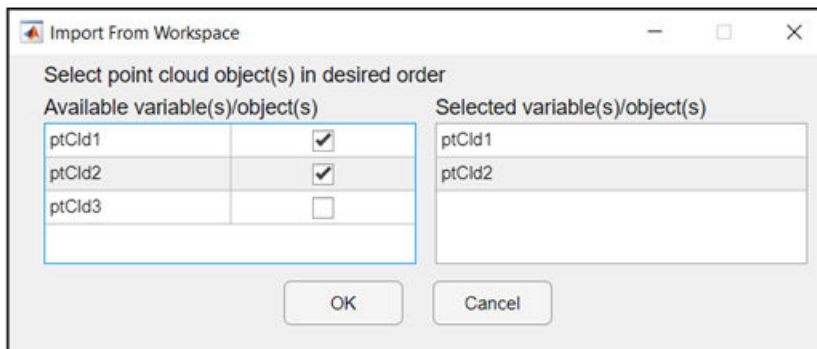

The app loads and plots point cloud data in the **Point Cloud Display** pane.

## Data Visualization

The **Lidar Viewer** app organizes loaded data, based on the order you import it, as a list in the **Data Browser** pane. To delete the imported data, right click on the data you want to delete and select **Delete Data**.

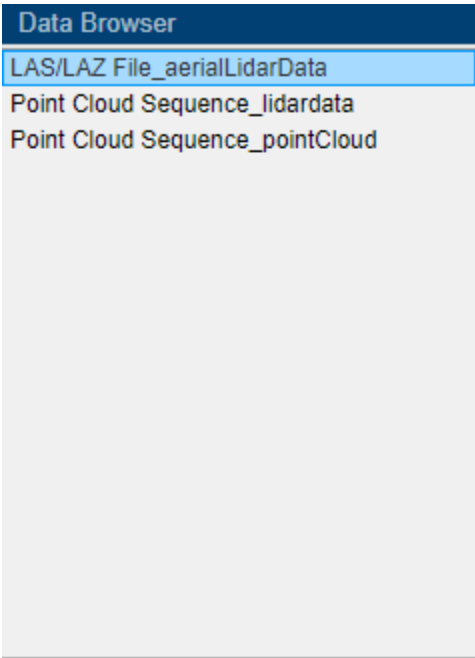

Select the data that you want to visualize. The metadata of the point cloud populates in the **Point Cloud Information** pane. The information and fields change based on the data source and available metadata.

Point Cloud Information	
Source Name	LAS/LAZ File_aerialL
Type	LAS/LAZ File
Points Count	1018047
X-Limits	[ 429745 , 430145 ]
Y-Limits	[ 3679831 , 3680114
Z-Limits	[ 73 , 126 ]
Current Frame Index	1
Number Of Frames	1

The visualization pane displays the point cloud data along with playback controls in the **Playback Slider**.

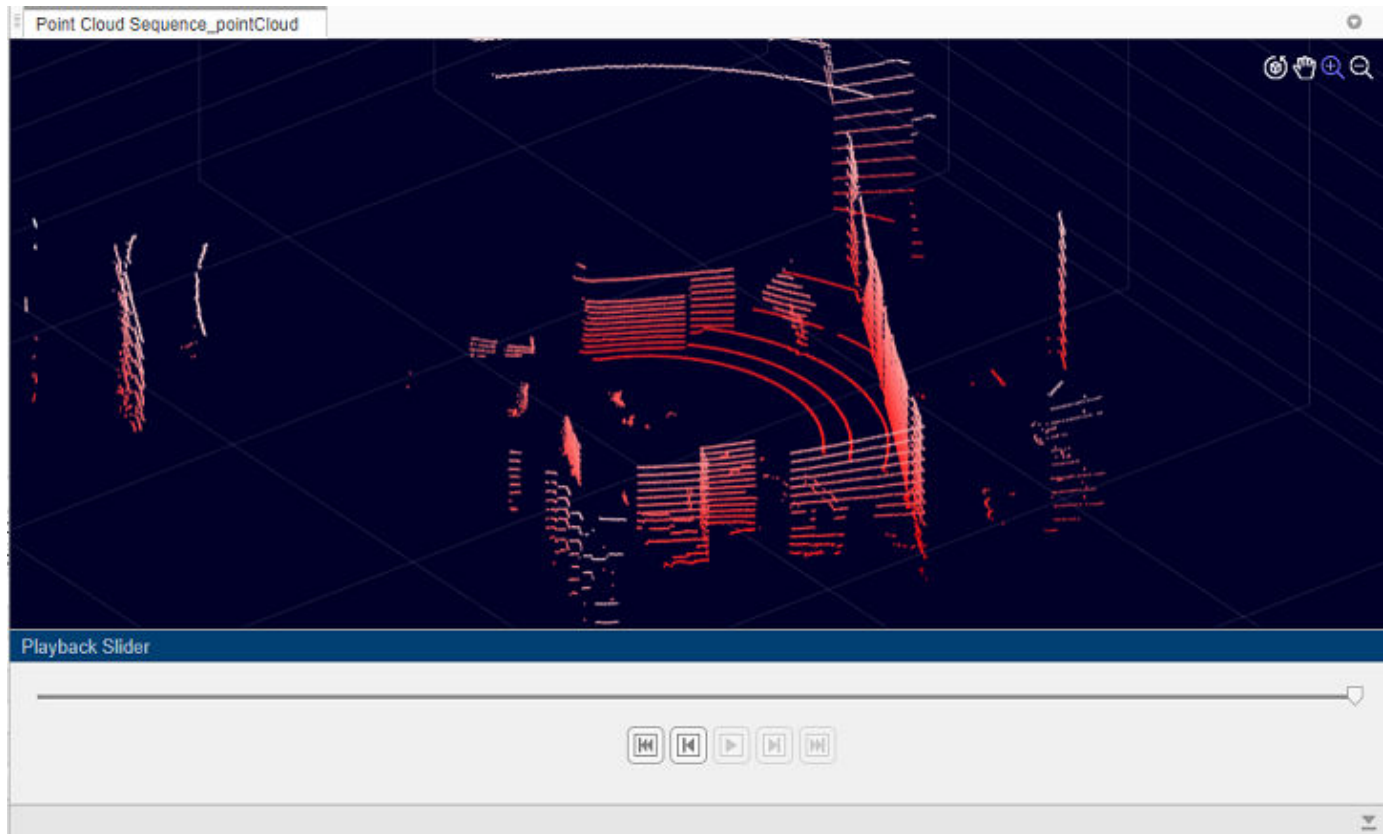

The **Playback Slider** pane contains a slider that indicates your current position in the point cloud sequence, as well as buttons to control the playback of the point cloud data. The buttons, from left to right, are:

- First Frame
- Previous Frame
- Play
- Next Frame
- Last Frame

If you select Play, the Play button becomes the Pause button, and all the playback controls except Pause are disabled.

For point cloud data with timestamp information such as PCAP, rosbag files, the app displays start time, current time, and end time on the **Playback Slider** pane.

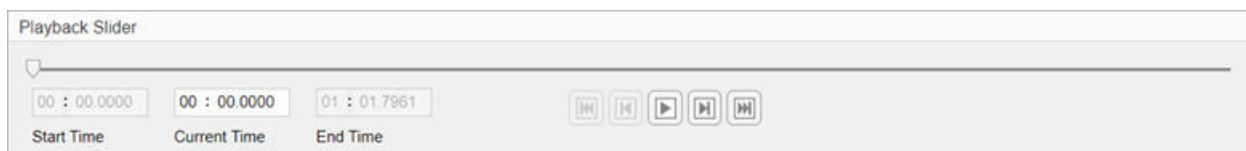

### Color Controls

**Lidar Viewer** provides various visualization features to analyze point cloud data. The app uses color to visualize more details about the displayed point cloud.

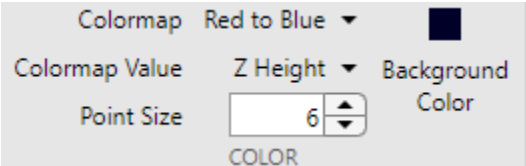

You can control the color of the displayed point cloud by using these options in the **Color** section of the app toolbar:

#### Colormap

Choose the color profile for the point cloud data, from these options.

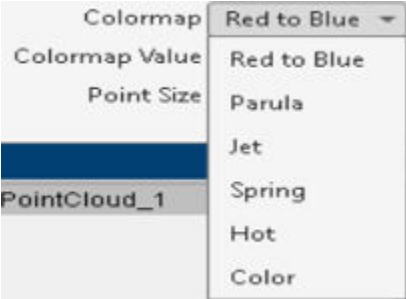

The app enables the **Color** option only when the input point cloud data has color information.

#### Colormap Value

Choose how the color profile applies to the point cloud, from these options:

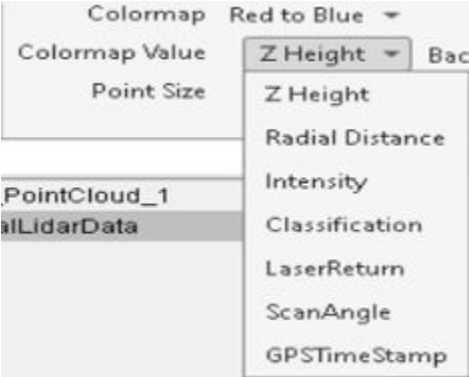

- **Z Height** — The color changes as the distance between points increases.
- **Radial Distance** — The color changes as the distance between points and the ego vehicle increases.
- **Intensity** — The color changes as the intensity value of points increases.

- **Classification** — The color changes based on the classification value of the point. For more information, see “Classification”.

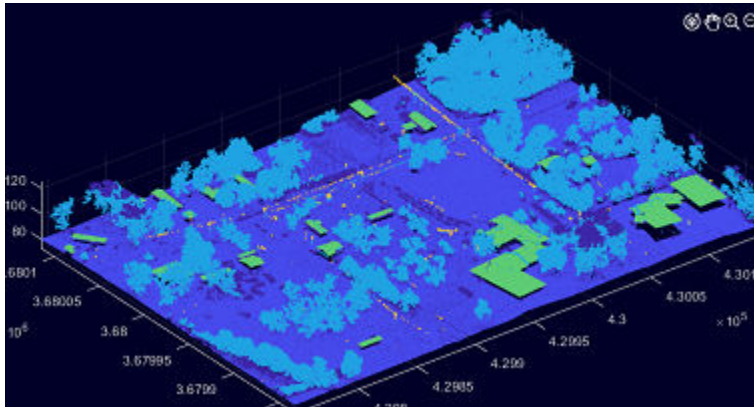

- **LaserReturn** — The color changes as the number of laser returns increases. The return number is the number of times a laser pulse reflects back to the sensor.
- **ScanAngle** — The color changes as the sensor scan angle increases. The scan angle is a value in degrees between -90 and 90. At 0 degrees, the laser pulse is directly below the aerial lidar sensor. At -90 degrees, the laser pulse is to the left side of the sensor, relative to the direction of flight. At 90 degrees, the laser pulse is to the right side of the sensor, relative to the direction of flight.

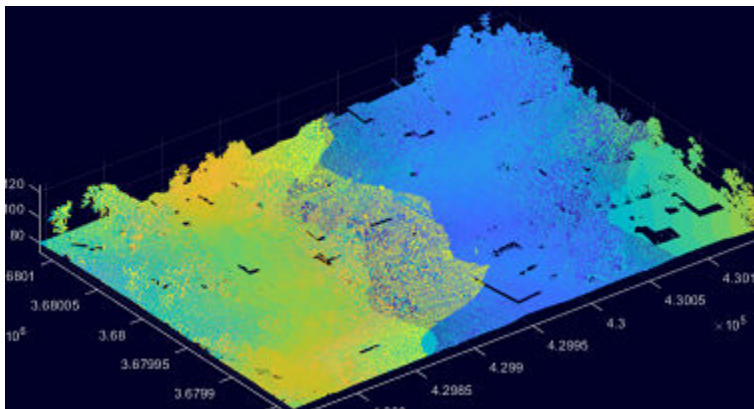

- **GPSTimeStamp** - The color changes as the timestamp of a point increases.

---

**Note** The app enables all the above options for **Colormap Value** with LAS/ LAZ data only. The default options for any other data format include Z Height, Radial Distance, Intensity.

---

### Point Size

Adjust the display size of points.

### Background Color

Select the background color for the point cloud display.



### Camera View Options

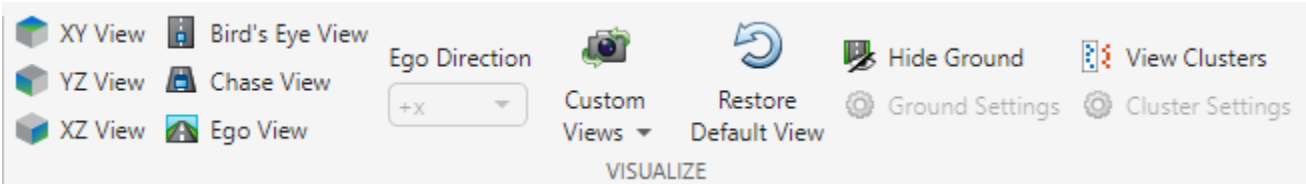

The app provides various predefined camera angles for viewing the point cloud data, as well as the option to create custom views:

#### XY View

View the xy-axes of a point cloud. This is the top view of the scene, line of sight is along z axis.

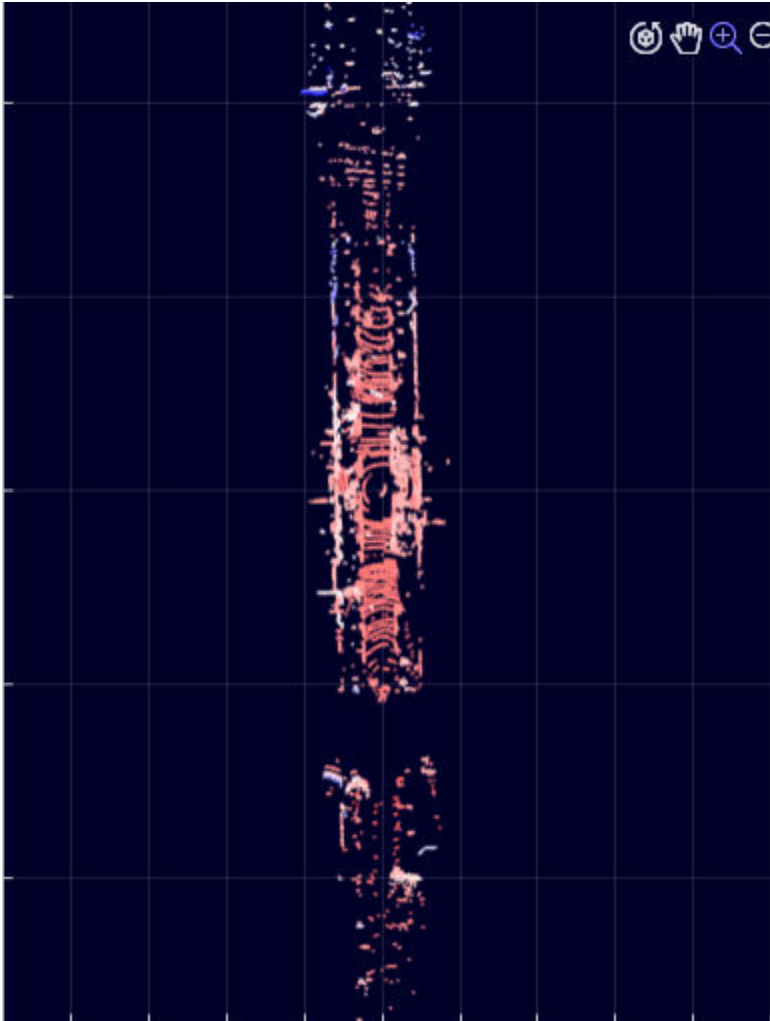

#### YZ View

View the yz-axes of a point cloud. This is the front view of the scene, line of sight is along x axis.

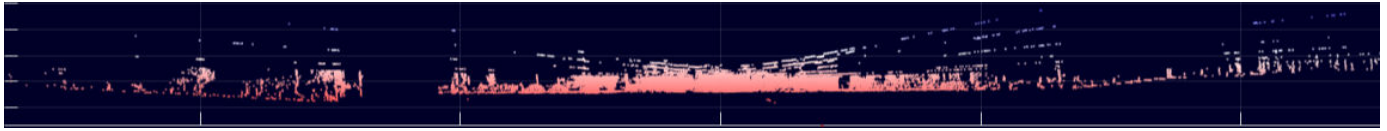

**XZ View**

View the xz-axes of a point cloud. This is the side view of the scene, line of sight is along y axis.

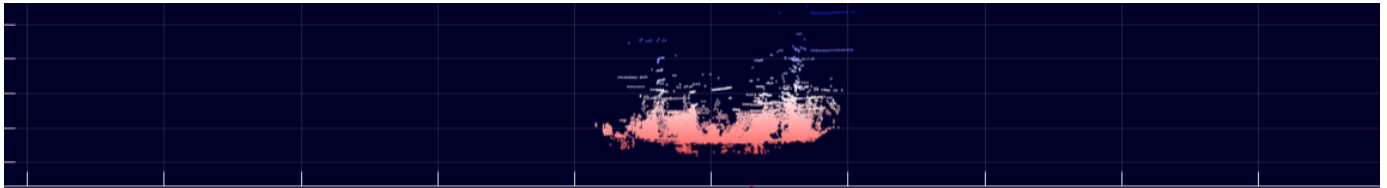

**Bird's Eye View**

View from a high angle above a point cloud.

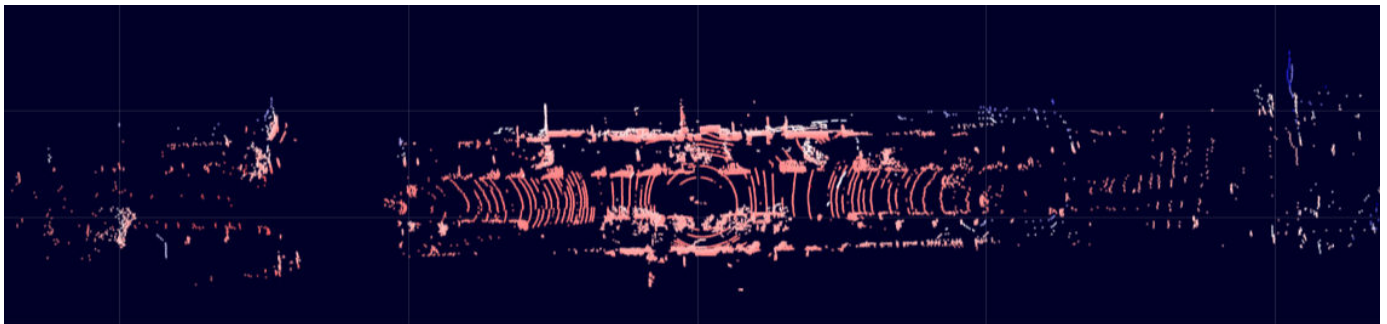

**Chase View**

View the point cloud from a fixed distance behind the ego vehicle (actor).

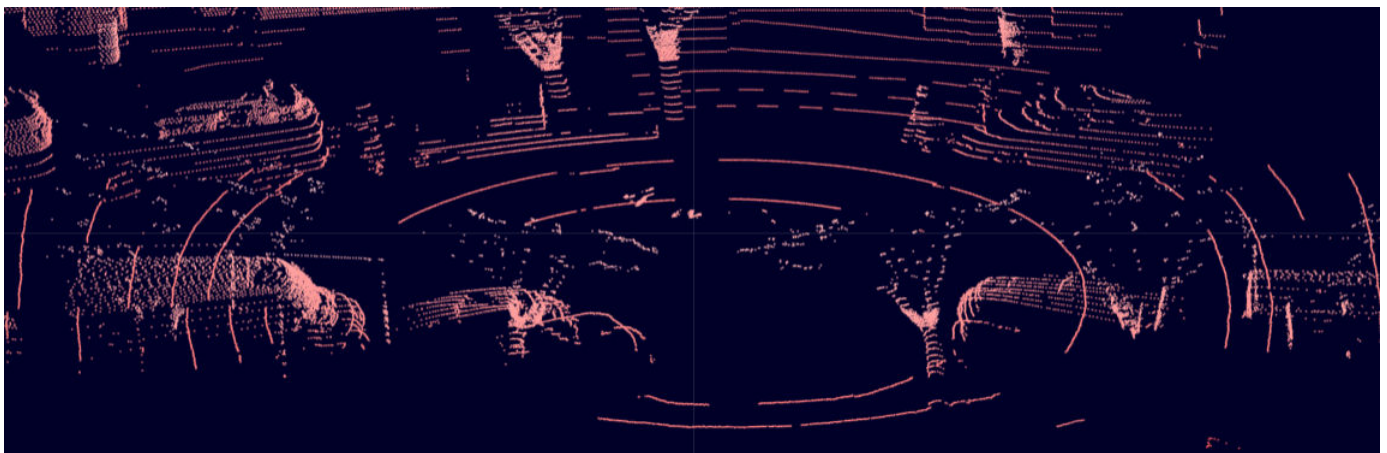

**Ego View**

View a point cloud from the perspective of the ego vehicle.

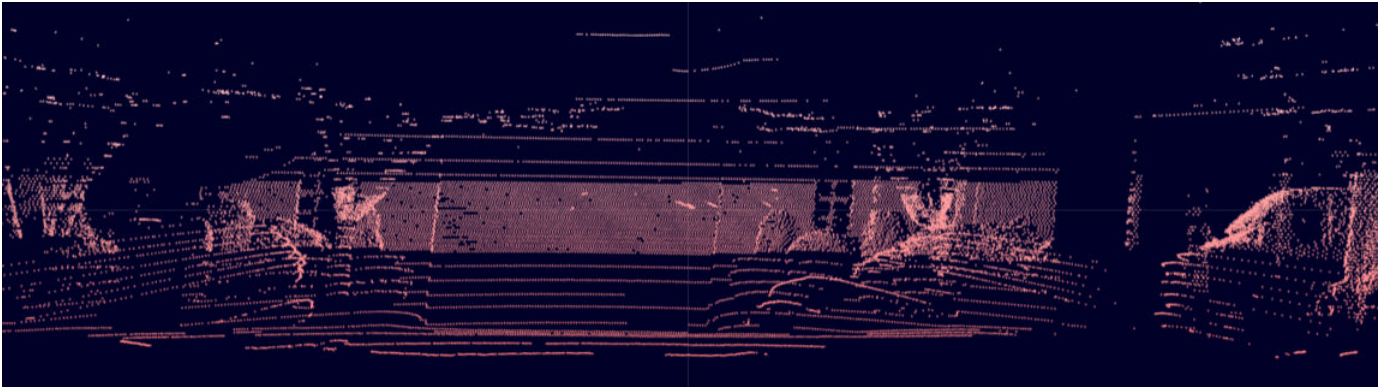

### Ego Direction

Use the **Ego Direction** list to select the direction the camera faces for **Ego View** and **Chase View**.

### Custom Views

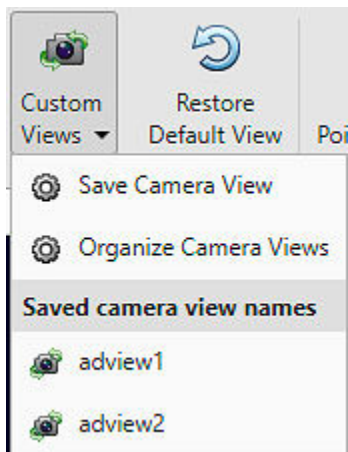

Select **Custom Views** to save and reuse custom views of the point cloud data. You can interactively rotate, pan, and zoom the camera to create a view, then save the view by clicking **Custom Views** and selecting **Save Camera View**. Specify a name for the view and select **OK**. You can return to the saved view at any time by clicking **Custom Views** and selecting the saved view from the list. Select **Organize Camera Views** from the list to delete or rename the saved views.

### Restore Default View

Restore the point cloud display to the default view.

## Hide Ground

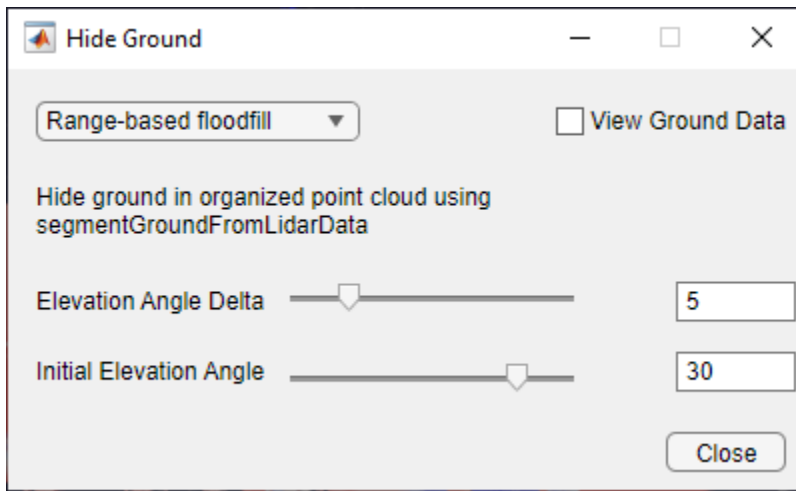

Select **Hide Ground** to remove ground points from the point cloud. This enables the **Ground Settings** option. Click **Ground Settings** to open a dialog box in which you can select from these ground removal algorithms and specify their parameters.

- Select **Range-based floodfill** to remove ground points using the `segmentGroundFromLidarData` function.
- Select **Fit ground plane** to fit and filter the ground plane using the `pcfitplane` function.
- Select **Segment ground SMRF** to filter the ground points using the `segmentGroundSMRF` function. The app enables this option for only organized point clouds.

To visualize the segmented ground and nonground planes on the point cloud, select **View Ground Data**.

## View Clusters

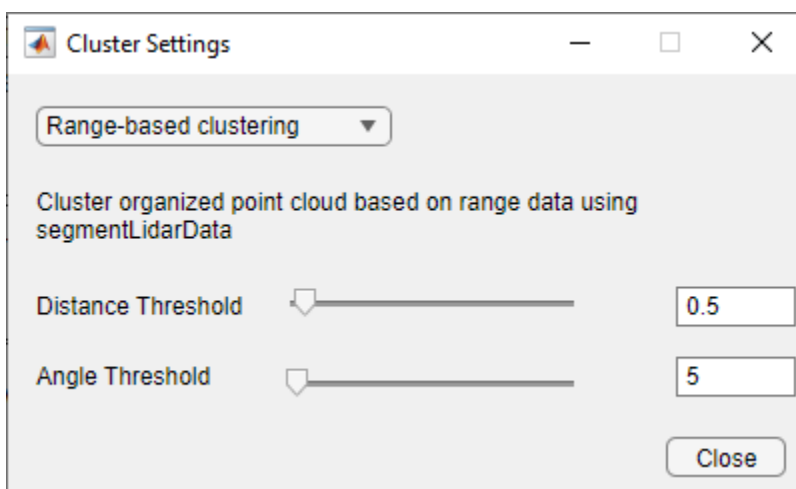

Select **View Cluster** to view point cloud clusters. This enables the **Cluster Settings** option. Click **Cluster Settings** to open a dialog box in which you can select from these cluster-based coloring algorithms.

- Select **Range-based clustering** to cluster point cloud data using the `segmentLidarData` function.
- Select **Distance-based clustering** to cluster point cloud data using the `pcsegdist` function.
- Select **k-means clustering** to perform k-means clustering on the points.

You can specify the algorithm parameters in the dialog box, and visualize the output point cloud clusters.

## Edit Point Cloud

Apply preprocessing operations to a point cloud by selecting on the **Edit Point Cloud** from the app toolstrip. The app opens the **Edit** tab. This tab retains the color and visualization features present in the **Lidar Viewer** tab . You can select built-in preprocessing operations from the **Algorithm** section of the toolstrip:

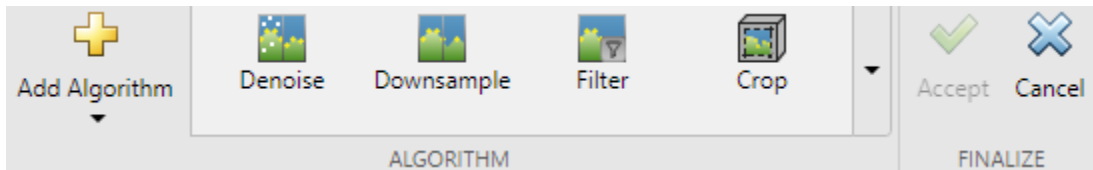

### Denoising

Remove noise from a 3-D point cloud using the `pcdenoise` function.

### Downsampling

Downsample a 3-D point cloud using the `pcdownsample` function.

### Filtering

Median filter 3-D point cloud data using the `pcmedian` function.

### Cropping

Crop a 3-D point cloud using cuboids. You can interactively adjust the cuboid limits, or specify them using the **Cuboid Limits** option. Select a **Crop Method** to specify whether to crop inside or outside the cuboid. Then, click **OK**. You can add multiple cuboids using the **Add Cuboid** option, and visualize the cropped point cloud.

Algorithm Parameters

Original Limits     Current Limits

Axis	Min	Max
X-Limits	4.2975e+05	4.3015e+05
Y-Limits	3.6798e+06	3.6801e+06
Z-Limits	72.7900	125.8200

Crop Method: Inside

Crop data inside/outside the cuboid

Add Cuboid

Cuboid Limits

X-Limits: 4.297e+ 4.301e+

Y-Limits: 3.68e+0 3.68e+0

Z-Limits: 72.79 125.8

### Ground Removal

Segment the ground plane from 3-D point cloud data. You can select from these algorithms:

- Fit Ground Plane — Fit and filter ground plane using the `pcfitplane` function.
- Hide Ground — Hide ground using the `segmentGroundFromLidarData` function.
- Segment Ground — Segment ground using the `segmentGroundSMRF` function.

### Organizing

Convert the 3-D point cloud into an organized point cloud using the `pcorganize` function. For more information, see “What are Organized and Unorganized Point Clouds?” on page 4-17

After selecting an algorithm, the app populates the **Algorithm Parameters** pane with the corresponding tunable parameters.

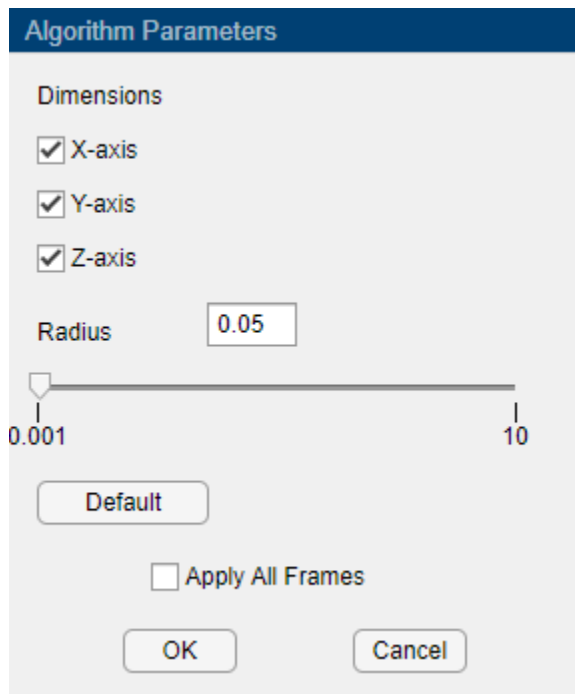

### Algorithm Parameters

The **Lidar Viewer** app dynamically updates the point cloud as you tune the parameters, enabling you to see the results in realtime. Select **Apply All Frames** to apply the algorithm to all the frames in the data source. After tuning your parameters select **OK**. The **History** pane records all preprocessing operations applied to the current frame. You can apply the same algorithm multiple times on the data using **OK**. Select **Cancel** to exit the edit algorithm.

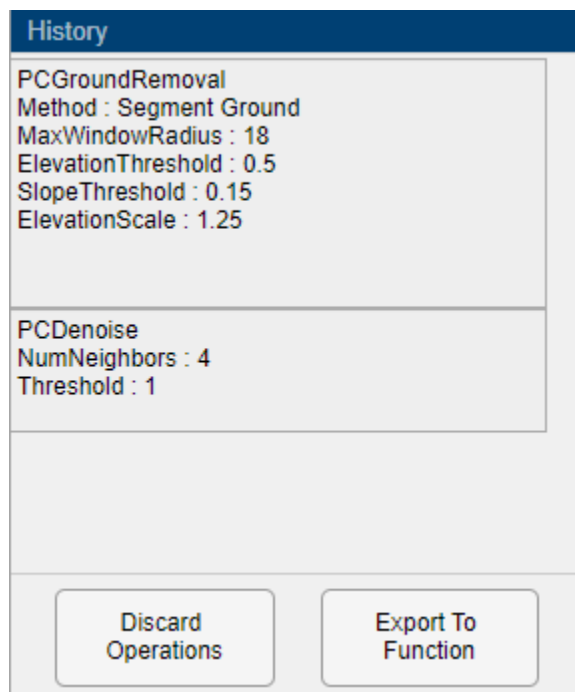

You can discard all applied algorithms by selecting **Discard Operations**. You can also export the selected preprocessing steps and the parameters, as a function by selecting **Export To Function**. The app creates a MAT file containing your custom preprocessing function. The function accepts a pointCloud object as input and outputs the processed pointCloud object.

## Custom Preprocessing Algorithms

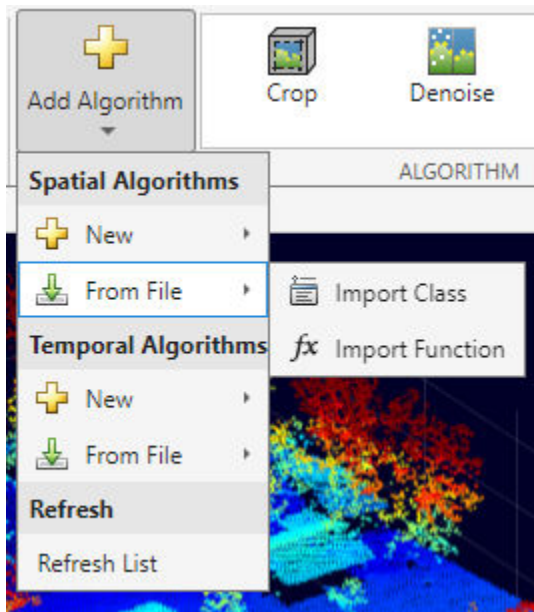

You can create a new custom preprocessing algorithm or import an existing one into the app. Follow these steps to apply a custom preprocessing algorithm to your data.

- 1 Click **Add Algorithm**. To apply your algorithm to only a single point cloud frame, select an option from the **Spatial Algorithms** section. To apply your algorithm to multiple point cloud frames, select an option from the **Temporal Algorithms** section.
- 2 To create a new algorithm, select **New**. Select whether to create an algorithm using a **Class Template** or a **Function Template**. MATLAB opens a new MAT file that contains a code framework and directions to create your custom algorithm. With the template, you can also define user interface (UI) elements for parameter tuning. These UI elements appear in the **Algorithm Parameters** pane.
- 3 To import your algorithm into the app, first select **Add Algorithm** and, in the **Spatial Algorithms** or **Temporal Algorithms** section, select **From File**. Then, select **Import Class** or **Import Function**. In the dialog box, select the file that contains the algorithm you want to import.

To finalize your edits to the point cloud and return to the **Edit** tab, on the app toolstrip, select **Accept**.

You can also export the history of edit operations to a function-based algorithm using **Export To Function**.

For more information on creating custom preprocessing workflows, see “Create Custom Preprocessing Workflow with Lidar Viewer” on page 3-2.



## Export Point Cloud

You can export point clouds as PCD or PLY files. After processing your point clouds, on the app toolstrip, select **Export Point Cloud**. **Lidar Viewer** opens the **Export Point Cloud** dialog box.

Select the point clouds you want to export. Then, in the **Provide path to the destination folder** text box, specify or browse to the destination folder.

**Note** If the input point cloud data is in PLY format, the app exports it as a PLY file. If you load input data of any other format, the app exports them as PCD files.

## Measure Point Cloud

You can measure point cloud attributes such as distance, angle, and volume using the tools in the **Measurement** tab.

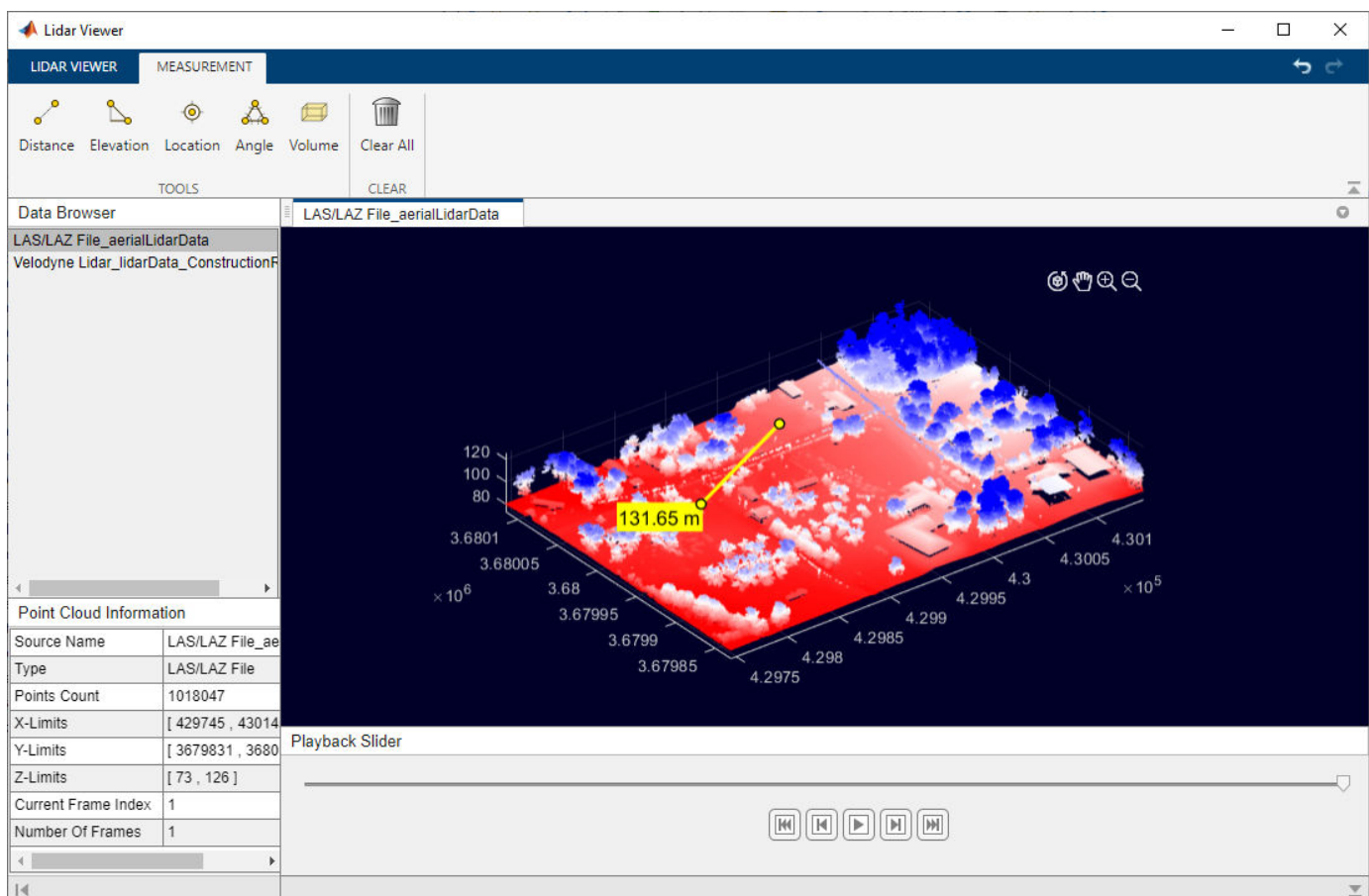

To measure an attribute of the point cloud, select a measurement tool on the app toolstrip, then interactively select points on the point cloud to return the corresponding measurement.

- **Distance** — Measure the distance between any two points in the point cloud.

- **Elevation** — Measure the elevation between any two points in the point cloud.
- **Location** — Obtain the xyz-coordinates of a point.
- **Angle** — Select three points on the point cloud to measure the angles of the triangle defined by the points.
- **Volume** — Measure the volume inside a cuboid region on the point cloud. You can interactively adjust the limits and the size of the cuboid.

---

**Note** The app deletes all your measurements in the current signal when you select **Edit Point Cloud** on the app toolbar, or toggle to a different point cloud signal.

---

## See Also

### Apps

Lidar Viewer | Lidar Labeler

### Functions

pcshow | pointCloud | pcdownsampling | pcmedian | pcdenoise | pcorganize | segmentGroundSMRF | pcfitplane | segmentGroundFromLidarData

### Objects

pointCloud | lasFileReader

## More About

- “Create Custom Preprocessing Workflow with Lidar Viewer” on page 3-2

## Getting Started with PointPillars

PointPillars is a method for 3-D object detection using 2-D convolutional layers. PointPillars network has a learnable encoder that uses PointNets to learn a representation of point clouds organized in pillars (vertical columns). The network then runs a 2-D convolutional neural network (CNN) to produce network predictions, decodes the predictions, and generates 3-D bounding boxes for different object classes such as cars, trucks, and pedestrians.

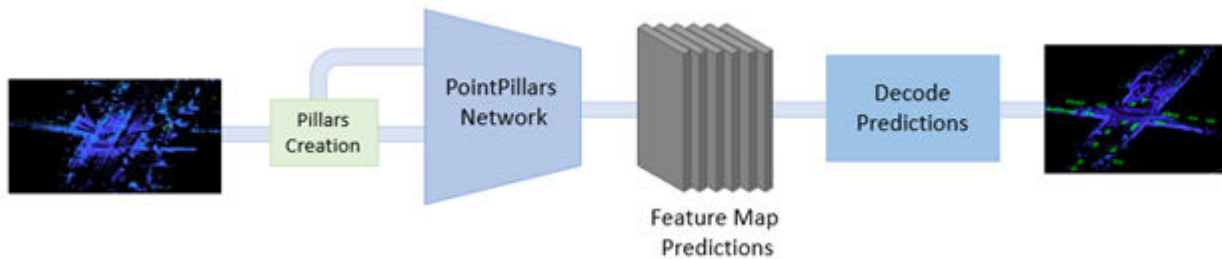

The PointPillars network has these main stages.

- 1 Use a feature encoder to convert a point cloud to a sparse pseudoimage.
- 2 Process the pseudoimage into a high-level representation using a 2-D convolution backbone.
- 3 Detect and regress 3D bounding boxes using detection heads.

### PointPillars Network

A PointPillars network requires two inputs: pillar indices as a  $P$ -by-2 and pillar features as a  $P$ -by- $N$ -by- $K$  matrix.  $P$  is the number of pillars in the network,  $N$  is the number of points per pillar, and  $K$  is the feature dimension.

The network begins with a feature encoder, which is a simplified PointNet. It contains a series of convolution, batch-norm, and relu layers followed by a max pooling layer. A scatter layer at the end maps the extracted features into a 2-D space using the pillar indices.

Next, the network has a 2-D CNN backbone that consists of encoder-decoder blocks. Each encoder block consists of convolution, batch-norm, and relu layers to extract features at different spatial resolutions. Each decoder block consists of transpose convolution, batch-norm, and relu layers.

The network then concatenates output features at the end of each decoder block, and passes these features through six detection heads with convolutional and sigmoid layers to predict occupancy, location, size, angle, heading, and class.

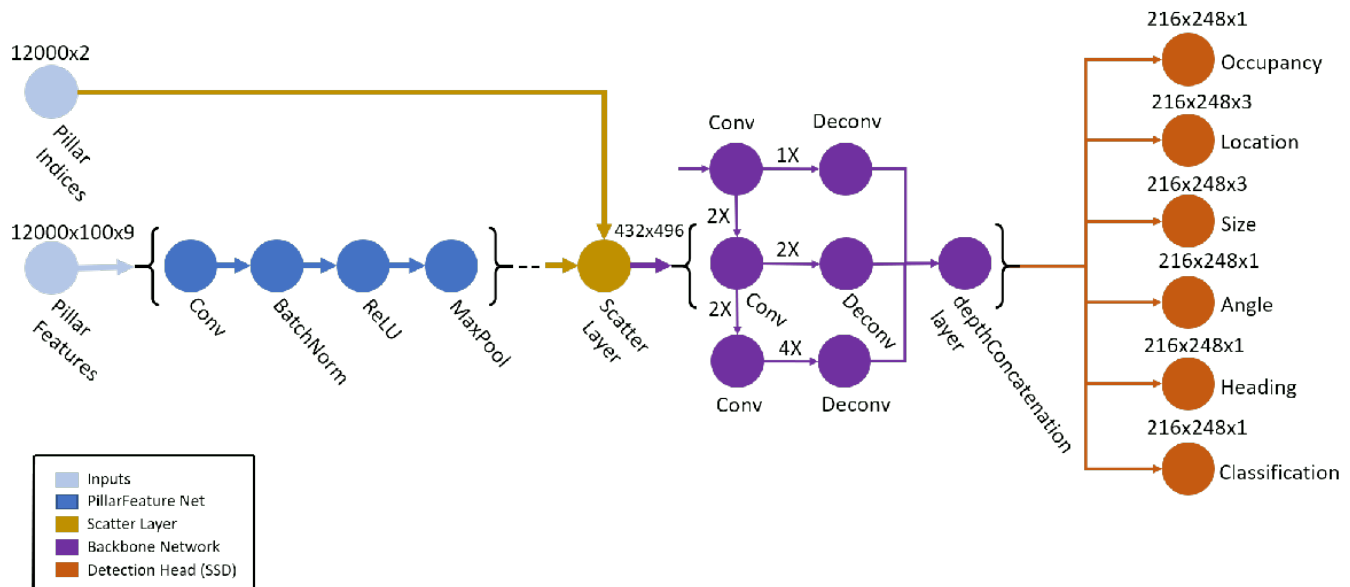

## Create PointPillars Network

You can use the **Deep Network Designer** app to interactively create a PointPillars deep learning network. To programmatically create a PointPillars network, use the `pointPillarsObjectDetector` object.

## Transfer Learning

Reconfigure a pretrained PointPillars network by using the `pointPillarsObjectDetector` object to perform transfer learning. Specify the new object classes and the corresponding anchor boxes to train the network on a new dataset.

## Train PointPillars Object Detector and Perform Object Detection

Use the `trainPointPillarsObjectDetector` function to train a PointPillars network. To perform object detection on a trained PointPillars network, use the `detect` function. For more information on how to train a PointPillars network, see “Lidar 3-D Object Detection Using PointPillars Deep Learning” on page 1-189.

## Code Generation

To learn how to generate CUDA® code for a PointPillars Network, see “Code Generation For Lidar Object Detection Using PointPillars Deep Learning” on page 1-319.

## References

- [1] Lang, Alex H., Sourabh Vora, Holger Caesar, Lubing Zhou, Jiong Yang, and Oscar Beijbom. “PointPillars: Fast Encoders for Object Detection From Point Cloud” In *2019 IEEE/CVF Conference on Computer Vision and Pattern Recognition (CVPR)*, 12689–97. Long Beach, CA, USA: IEEE, 2019. <https://doi.org/10.1109/CVPR.2019.01298>.

[2] Hesai and Scale. PandaSet. <https://scale.com/open-datasets/pandaset>.

## See Also

### Apps

**Deep Network Designer** | **Lidar Viewer** | **Lidar Labeler**

### Objects

`pointPillarsObjectDetector`

### Functions

`trainPointPillarsObjectDetector` | `detect`

## Related Examples

- “Lidar 3-D Object Detection Using PointPillars Deep Learning” on page 1-189
- “Code Generation For Lidar Object Detection Using PointPillars Deep Learning” on page 1-319
- “Lane Detection in 3-D Lidar Point Cloud” on page 1-272
- “Unorganized to Organized Conversion of Point Clouds Using Spherical Projection” on page 1-265

## More About

- “Deep Learning in MATLAB” (Deep Learning Toolbox)
- “Getting Started with Point Clouds Using Deep Learning”

## Getting Started with PointNet++

PointNet++ is a popular neural network used for semantic segmentation of unorganized lidar point clouds. Semantic segmentation associates each point in a 3-D point cloud with a class label, such as car, truck, ground, or vegetation.

PointNet++ network partitions the input points into a set of clusters and then extracts the features using a multi-layer perceptron (MLP) network. The network applies PointNet recursively on the nested, partitioned inputs to extract multi-scale features for accurate semantic segmentation.

Applications of PointNet++ include:

- Tree segmentation for digital forestry applications.
- Extracting a digital terrain model from aerial lidar data.
- Perception for indoor navigation in robotics.
- 3-D city modelling from aerial lidar data.

### PointNet++ Network

The PointNet++ network contains an encoder with set abstraction modules and a decoder with feature propagation modules.

The set abstraction module processes and extracts a set of points to produce a new set with fewer elements. Each set abstraction module contains a sampling and grouping layer followed by a mini-PointNet network.

- The sampling and grouping layer performs sampling by identifying the centroids of local regions. It then performs grouping by constructing local region sets of the neighboring points around the centroids.
- The mini-PointNet network contains a shared MLP network with a series of convolution, normalization, relu layers followed by a max pooling layer. It encodes the local region patterns into feature vectors.

The feature propagation module interpolates the subsampled points and then concatenates them with the point features from the set abstraction modules. The network then passes these features through the unit PointNet network.

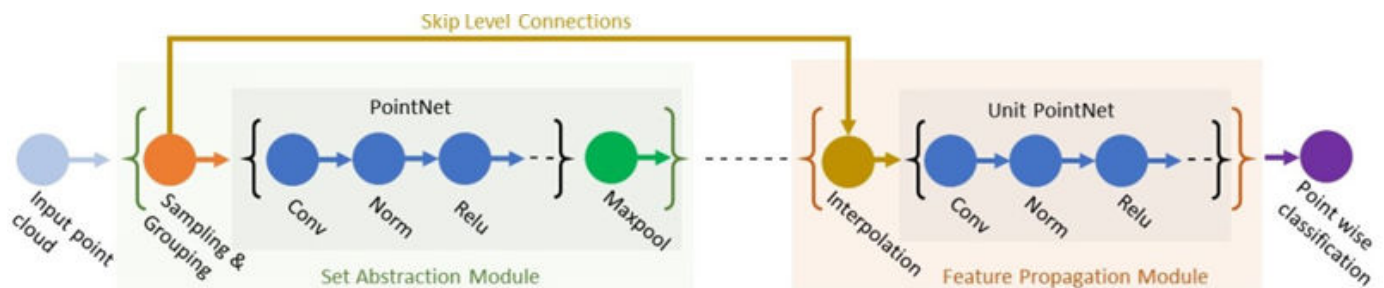

The sampling & grouping layer of the set abstraction module and the interpolation layer of the feature propagation module in this network are implemented using the `functionLayer` function.

## Create PointNet++ Network

Use the `pointnetplusLayers` function to create a PointNet++ network for segmenting point cloud data.

## Train PointNet++ Network

To learn how to train a PointNet++ network for segmenting point cloud data, see “Aerial Lidar Semantic Segmentation Using PointNet++ Deep Learning” on page 1-324.

## Code Generation

To learn how to generate CUDA® code for a PointNet++ network, see “Code Generation For Aerial Lidar Semantic Segmentation Using PointNet++ Deep Learning” on page 1-95.

## References

- [1] Qi, Charles R., Li Yi, Hao Su, and Leonidas J. Guibas. ‘PointNet++: Deep Hierarchical Feature Learning on Point Sets in a Metric Space’. *ArXiv:1706.02413 [Cs]*, 7 June 2017. <https://arxiv.org/abs/1706.02413>.
- [2] Varney, Nina, Vijayan K. Asari, and Quinn Graehling. ‘DALES: A Large-Scale Aerial LiDAR Data Set for Semantic Segmentation’. *ArXiv:2004.11985 [Cs, Stat]*, 14 April 2020. <https://arxiv.org/abs/2004.11985>.

## See Also

### Apps

[Deep Network Designer](#) | [Lidar Viewer](#) | [Lidar Labeler](#)

### Functions

[pointnetplusLayers](#) | [squeezeSegV2Layers](#) | [semanticseg](#) | [trainNetwork](#) | [evaluateSemanticSegmentation](#)

## Related Examples

- “Aerial Lidar Semantic Segmentation Using PointNet++ Deep Learning” on page 1-324
- “Code Generation For Aerial Lidar Semantic Segmentation Using PointNet++ Deep Learning” on page 1-95
- “Lidar Point Cloud Semantic Segmentation Using SqueezeSegV2 Deep Learning Network” on page 1-173
- “Lidar Point Cloud Semantic Segmentation Using PointSeg Deep Learning Network” on page 1-128

## More About

- “Deep Learning in MATLAB” (Deep Learning Toolbox)
- “Getting Started with Point Clouds Using Deep Learning”





# Tutorials

---

- “Generate Lidar Point Cloud Data for Driving Scenario with Multiple Actors” on page 5-2
- “Read Point Cloud Data from LAZ File” on page 5-6
- “Estimate Transformation Between Two Point Clouds Using Features” on page 5-7
- “Match and Visualize Corresponding Features in Point Clouds” on page 5-10
- “Read Lidar and Camera Data from Rosbag File” on page 5-13
- “Read, Process, and Write Lidar Point Cloud Data” on page 5-15
- “Extract Ground Points and Non-Ground Points From Lidar Data ” on page 5-20

## Generate Lidar Point Cloud Data for Driving Scenario with Multiple Actors

This example shows you how to generate lidar point cloud data for a driving scene with roads, pedestrians, and vehicles. First create a driving scenario by using the `drivingScenario` (Automated Driving Toolbox) object, and then configure a `lidarSensor` object to generate point cloud data for the scenario.

### Create Driving Scenario

Create a driving scenario using the `drivingScenario` (Automated Driving Toolbox) object, and define the ego vehicle.

```
scenario = drivingScenario;

% Add the ego vehicle
egoVehicle = vehicle(scenario, ...
    ClassID=1, ...
    Mesh=driving.scenario.carMesh);
waypoints = [1 -2 0; 35 -2 0];
trajectory(egoVehicle,waypoints,10);
```

Define the road and the lanes for the scenario as `Actor` objects using the `actor` (Automated Driving Toolbox) function. Specify a custom value for the `ClassID` property of each actor. Using the `actor` (Automated Driving Toolbox) function to create roads enables you to define the mesh representation for the road, to generate point cloud data. Otherwise, the function does not generate points for the road.

```
actor(scenario,ClassID=7,Length=200,Width=20,Height=0.1);
actor(scenario,ClassID=7,Length=200,Width=0.3, ...
    Height=0.1,Position=[0 -5 0.02]);
actor(scenario,ClassID=7,Length=200,Width=0.3, ...
    Height=0.1,Position=[0 5 0.02]);
```

Add a car, truck, pedestrian, and bicycle to the scene as other actors.

```
% Add a moving car with a speed of 20 meters per second.
movingCar = vehicle(scenario, ...
    ClassID=1, ...
    Mesh=driving.scenario.carMesh);
waypoints = [90 -5 0; 15 -5 0];
speed = 20;
trajectory(movingCar,waypoints,speed);

% Add a truck with a speed of 15 meters per second.
truck = vehicle(scenario, ...
    ClassID=2, ...
    Length=8.2, ...
    Width=2.5, ...
    Height=3.5, ...
    Mesh=driving.scenario.truckMesh);
waypoints = [70 1.7 0; 20 1.9 0];
speed = 15;
trajectory(truck,waypoints,speed);
```

```
% Add a pedestrian.
```

```

pedestrian = actor(scenario, ...
    ClassID=4, ...
    Length=0.24, ...
    Width=0.45, ...
    Height=1.7, ...
    Mesh=driving.scenario.pedestrianMesh);
waypoints = [23 -4 0; 10.4 -4 0];
speed = 1.5;
trajectory(pedestrian,waypoints,speed);

% Add a bicycle.
bicycle = actor(scenario, ...
    ClassID=3, ...
    Length=1.7, ...
    Width=0.45, ...
    Height=1.7, ...
    Mesh=driving.scenario.bicycleMesh);
waypoints = [12.7 -3.3 0; 49.3 -3.3 0];
speed = 5;
trajectory(bicycle,waypoints,speed);
plot(scenario,Waypoints="on")
title("Driving scenario with actors")

```

### Generate Point Cloud Data

Create a lidarSensor object.

```

lidar = lidarSensor(AzimuthResolution=0.5, ...
    ElevationAngles=[-25:1.6:10 11:1:20]);

```

Generate the actor profiles from your driving scenario and assign them to the lidarSensor object.

```

lidar.ActorProfiles = actorProfiles(scenario);

```

Create a pcplayer object to visualize the output point cloud.

```

player = pcplayer([-60 60],[-20 20],[0 5]);

```

Advance the scene and generate point cloud data.

```

while advance(scenario) && player.isOpen()
    % Get updated target poses from the scenario object
    tgts = targetPoses(egoVehicle);

    % Generate and visualize point cloud data
    [ptCloud,isValidTime] = lidar(tgts,scenario.SimulationTime);
    if isValidTime
        view(player,ptCloud);
    end
end

```

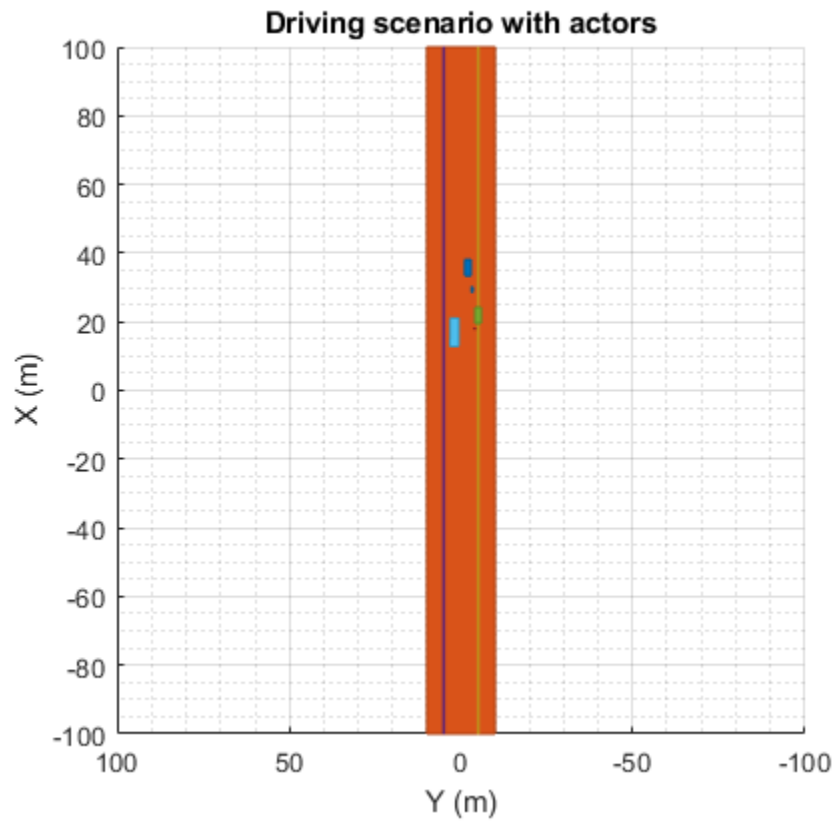

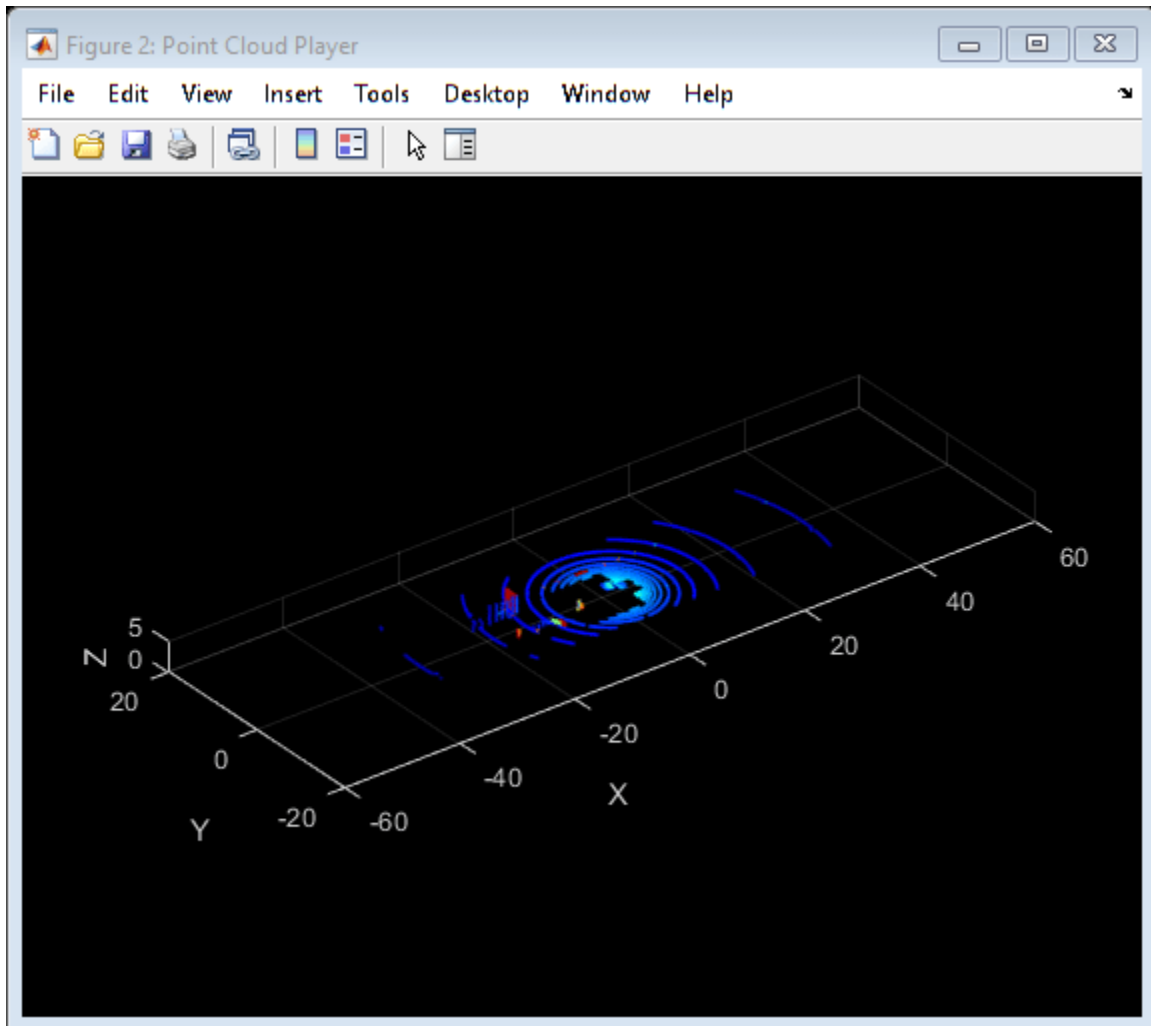

## See Also

### Functions

`lidarSensor` | `drivingScenario`

## Read Point Cloud Data from LAZ File

This example shows how to read and visualize point cloud data from a LAS / LAZ file.

Create a `lasFileReader` object for a LAZ file. Then, use the `readPointCloud` function to read point cloud data from the LAZ file and generate a `pointCloud` object.

Create a `lasFileReader` object to access the LAZ file data.

```
path = fullfile(toolboxdir("lidar"), "lidardata", ...  
    "las", "aerialLidarData.laz");  
lasReader = lasFileReader(path);
```

Read point cloud data from the LAZ file using the `readPointCloud` function.

```
ptCloud = readPointCloud(lasReader);
```

Visualize the point cloud.

```
figure  
pcshow(ptCloud.Location)
```

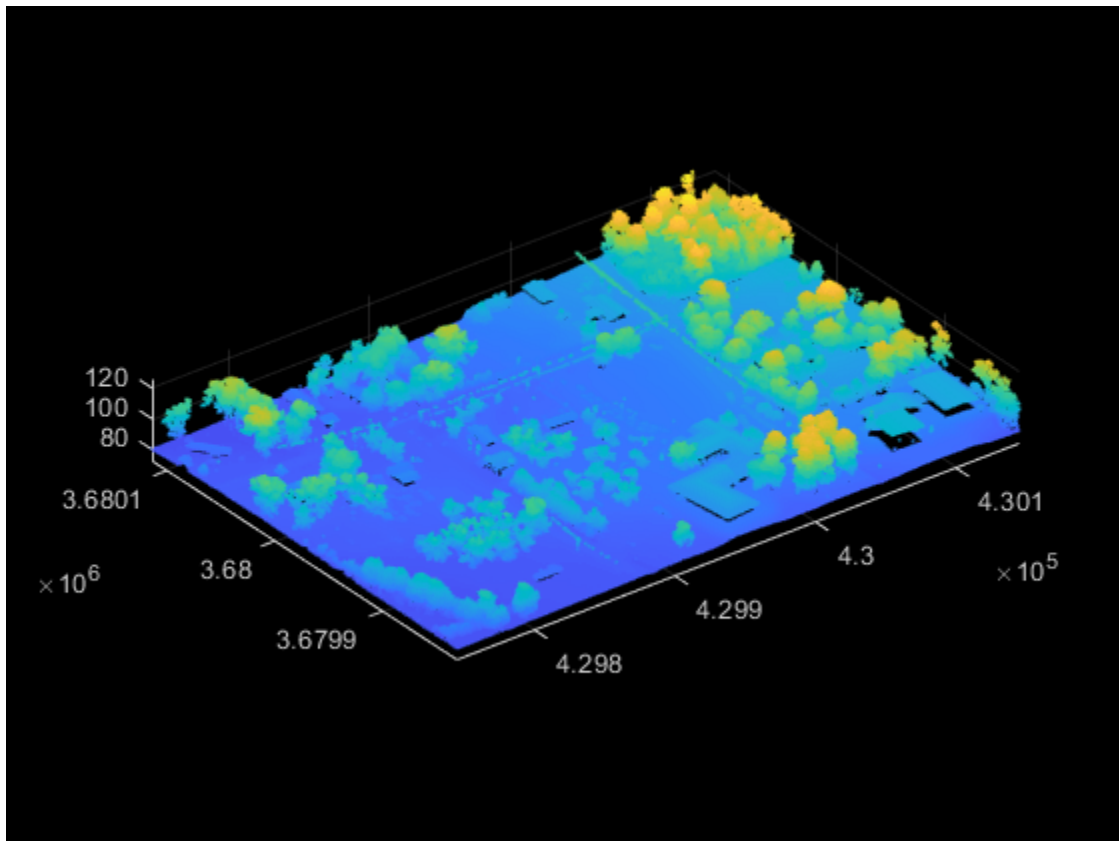

## Estimate Transformation Between Two Point Clouds Using Features

This example shows how to estimate a rigid transformation between two point clouds. In the example, you use feature extraction and matching to significantly reduce the number of points required for estimation. After you use the `extractFPFHFeatures` function to extract fast point feature histogram (FPFH) features from the point clouds, you use the `pcmatchfeatures` function to search for matches in the extracted features. Finally, you use the `estimateGeometricTransform3D` function and the matching features to estimate the rigid transformation.

### Preprocessing

Create two point clouds by applying rigid transformation to an input point cloud.

Read the point cloud data into the workspace.

```
rng("default")
ptCld = pcread("highwayScene.pcd");
ptCld.Count
```

```
ans = 65536
```

Downsample the point cloud to improve the computation speed, as it contains around 65,000 points.

```
ptCloud = pcdsample(ptCld,"gridAverage",0.2);
ptCloud.Count
```

```
ans = 24596
```

Create a rigid transformation matrix with a 30-degree rotation and translation of 5 units in x- and y-axes.

```
rotAngle = 30;
rot = [cosd(rotAngle) sind(rotAngle) 0; ...
      -sind(rotAngle) cosd(rotAngle) 0; ...
      0 0 1];
trans = [5 5 0];
tform = rigid3d(rot,trans);
```

Transform the input point cloud.

```
ptCloudTformed = pctransform(ptCloud,tform);
```

Visualize the two point clouds.

```
pcshowpair(ptCloud,ptCloudTformed)
xlim([-50 75])
ylim([-40 80])
legend("Original","Transformed","TextColor",[1 1 0])
```

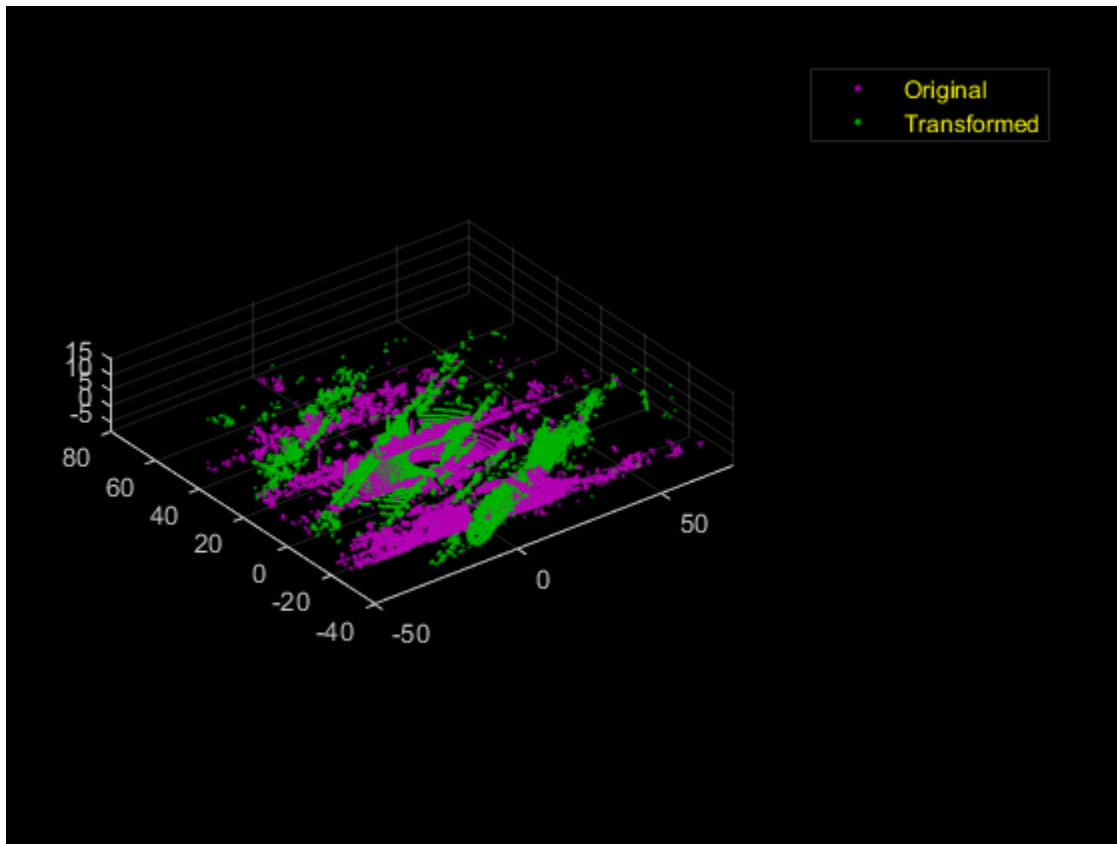

### Feature Extraction and Registration

Extract features from both the point clouds using the `extractFPFHFeatures` function.

```
fixedFeature = extractFPFHFeatures(ptCloud);
movingFeature = extractFPFHFeatures(ptCloudTformed);
```

Find matching features and display the number of matching pairs.

```
[matchingPairs,scores] = pcmatchfeatures(fixedFeature,movingFeature, ...
    ptCloud,ptCloudTformed,"Method","Exhaustive");
length(matchingPairs)
```

```
ans = 1814
```

Select matching points from the point clouds.

```
fixedPts = select(ptCloud,matchingPairs(:,1));
matchingPts = select(ptCloudTformed,matchingPairs(:,2));
```

Estimate the transformation matrix using the matching points.

```
estimatedTform = estimateGeometricTransform3D(fixedPts.Location, ...
    matchingPts.Location,"rigid");
disp(estimatedTform.T)
```

```
    0.8660    0.5000    0.0002    0
   -0.5000    0.8660   -0.0002    0
```



```
-0.0003    0.0000    1.0000    0
 4.9995    5.0022    0.0020    1.0000
```

Display the defined transformation matrix.

```
disp(tform.T)
```

```
 0.8660    0.5000         0         0
-0.5000    0.8660         0         0
         0         0    1.0000         0
 5.0000    5.0000         0    1.0000
```

Use the estimated transformation to retransform ptCloudTformed back to the initial point cloud.

```
ptCloudTformed = pctransform(ptCloudTformed,invert(estimatedTform));
```

Visualize the two point clouds.

```
pcshowpair(ptCloud,ptCloudTformed)
xlim([-50 50])
ylim([-40 60])
title("Aligned Point Clouds")
```

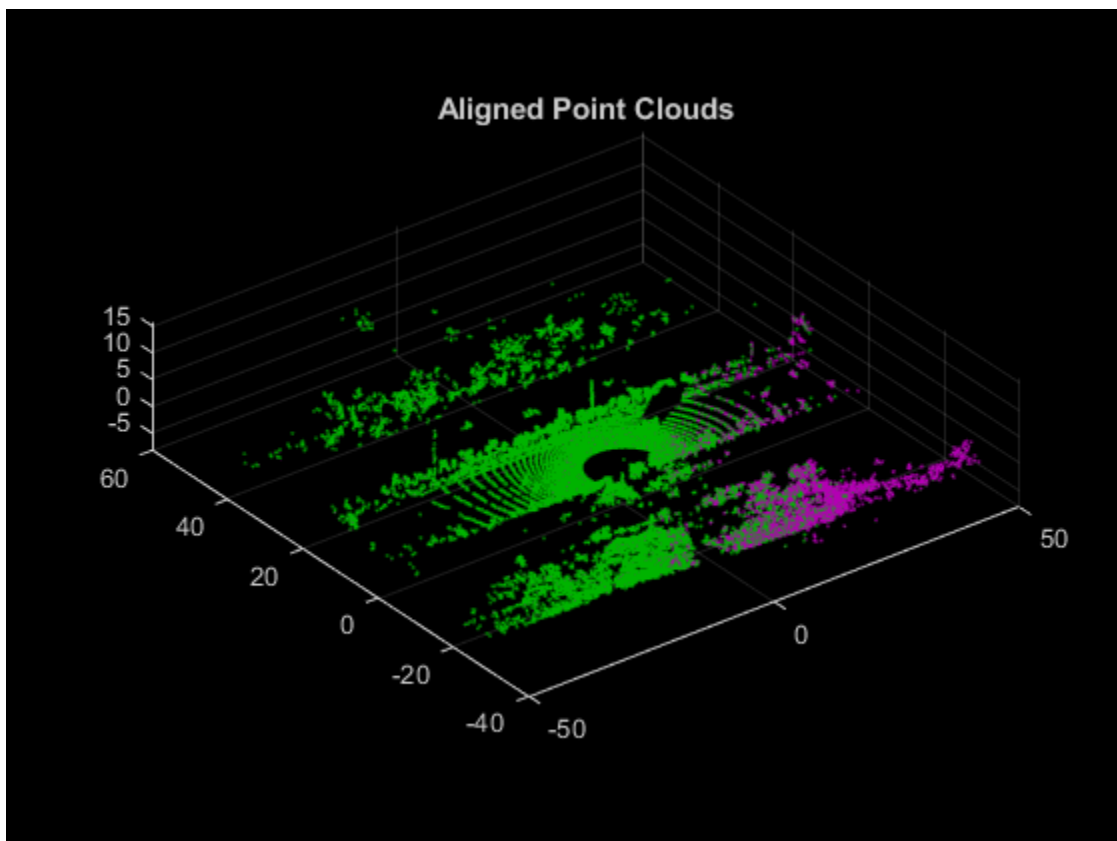

## Match and Visualize Corresponding Features in Point Clouds

This example shows how to match corresponding features between point clouds using the `pcmatchfeatures` function and visualize them using the `pcshowMatchedFeatures` function.

Create a `velodyneFileReader` object.

```
veloReader = velodyneFileReader('lidarData_ConstructionRoad.pcap', 'HDL32E');
```

Read two point clouds from the `velodyneFileReader` object into the workspace.

```
frameNumber = 1;
skipFrame = 5;
fixed = readFrame(veloReader, frameNumber);
moving = readFrame(veloReader, frameNumber+skipFrame);
```

Segment and remove the ground plane from the fixed point cloud and moving point cloud.

```
groundPtsIdxFixed = segmentGroundSMRF(fixed);
groundPtsIdxMoving = segmentGroundSMRF(moving);
fixedSeg = select(fixed, ~groundPtsIdxFixed, 'OutputSize', 'full');
movingSeg = select(moving, ~groundPtsIdxMoving, 'OutputSize', 'full');
figure
pcshowpair(movingSeg, fixedSeg)
ylim([-50 60])
title('Input Point Clouds')
```

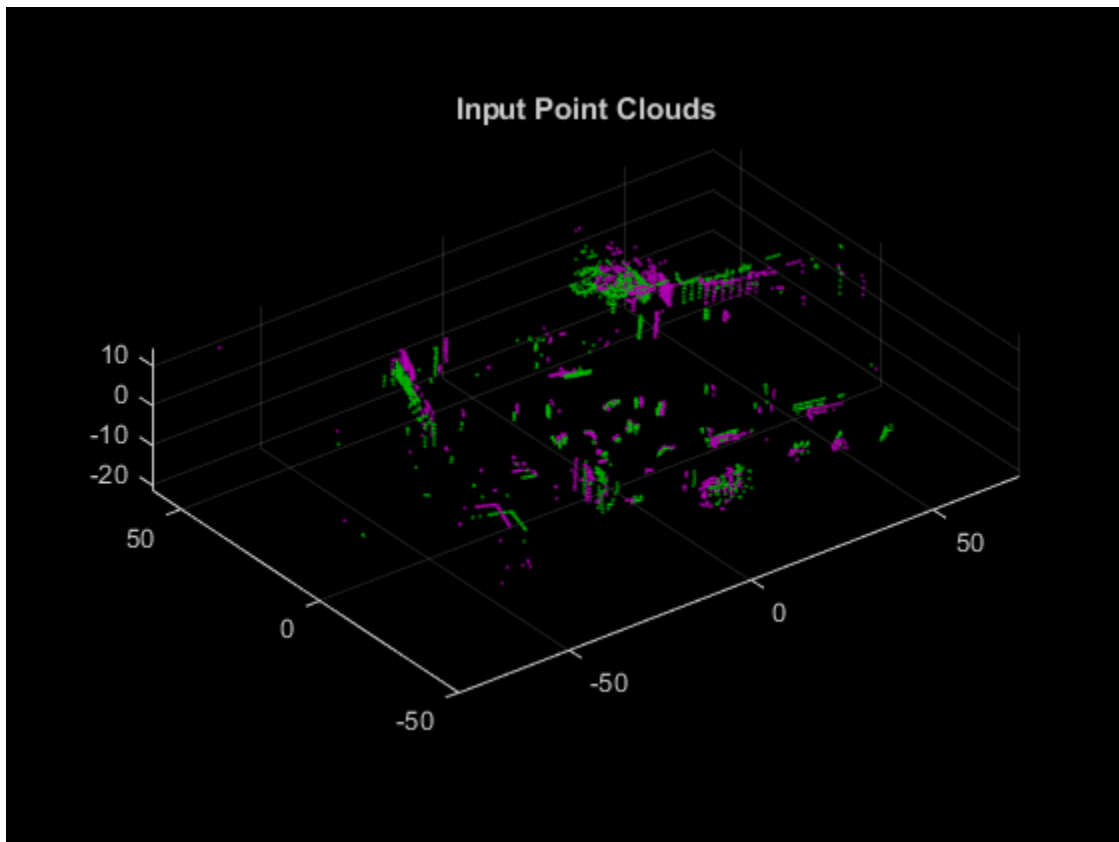

The superimposed input point clouds are color coded:

- Magenta — Moving point cloud
- Green — Fixed point cloud

Downsample the point clouds to reduce the computation time. Downsampling reduces the number of points to process.

```
fixedDownsampled = pcdsample(fixedSeg, 'gridAverage', 0.2);
movingDownsampled = pcdsample(movingSeg, 'gridAverage', 0.2);
```

Extract features from the point clouds using the `extractFPFHFeatures` function. The function returns valid indices in both the point clouds. Select the valid points and create new reference point clouds.

```
[fixedFeature, fixedValidInds] = extractFPFHFeatures(fixedDownsampled);
[movingFeature, movingValidInds] = extractFPFHFeatures(movingDownsampled);
fixedValidPts = select(fixedDownsampled, fixedValidInds);
movingValidPts = select(movingDownsampled, movingValidInds);
```

Match features between the point clouds using the extracted features and reference point clouds.

```
indexPairs = pcmatchfeatures(movingFeature, fixedFeature, movingValidPts, ...
    fixedValidPts);
```

If you do not have the corresponding point cloud data, you can use the two feature sets by themselves. The `pcmatchfeatures` function uses point cloud data to estimate the spatial relation between the points associated with potential feature matches and reject matches based on a spatial relation threshold.

Create point clouds of only the points in each point cloud with matching features in the other point cloud.

```
matchedFixedPts = select(fixedValidPts, indexPairs(:, 2));
matchedMovingPts = select(movingValidPts, indexPairs(:, 1));
```

Visualize the matches.

```
figure
pcshowMatchedFeatures(movingSeg, fixedSeg, matchedMovingPts, matchedFixedPts, ...
    'Method', 'montage')
xlim([-40 210])
ylim([-50 50])
title('Matched Points')
```

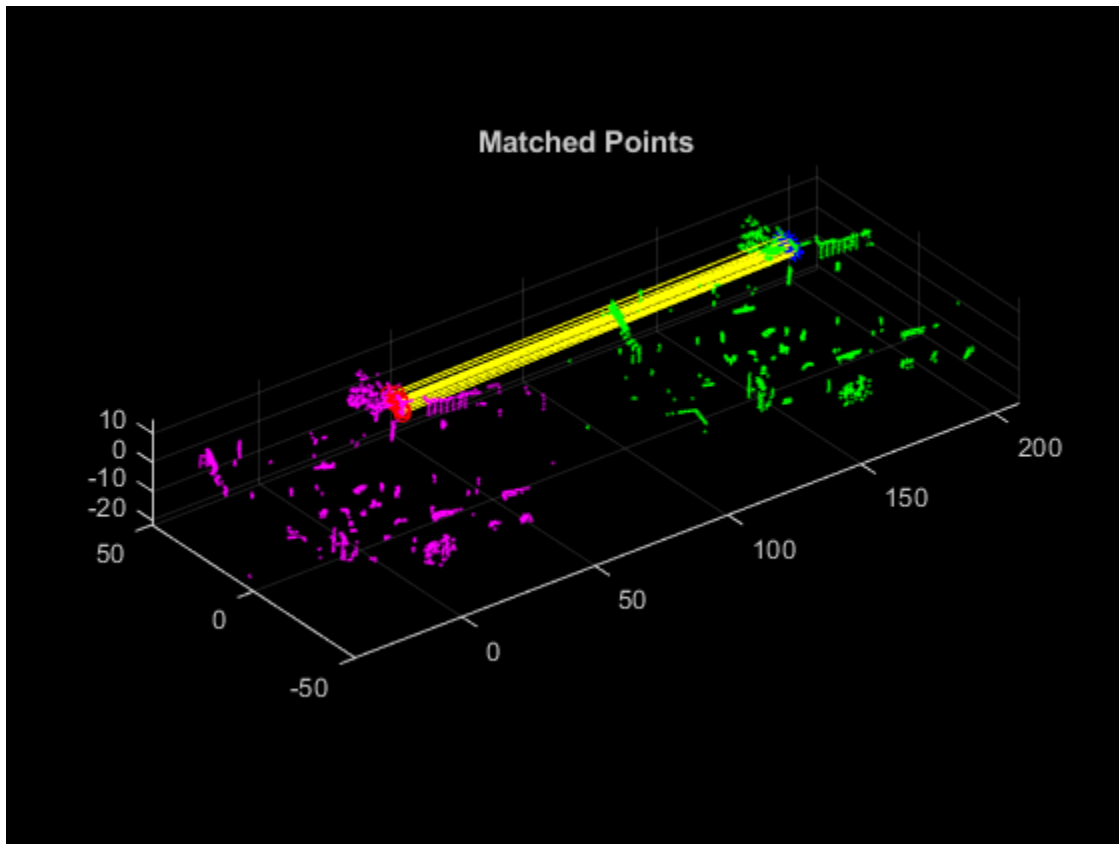

The matched features and point clouds are color coded to improve visualization:

- Magenta — Moving point cloud
- Green — Fixed point cloud
- Red circle — Matched points in the moving point cloud
- Blue asterisk — Matched points in the fixed point cloud
- Yellow — Line connecting the matched features

## Read Lidar and Camera Data from Rosbag File

This example shows how to read and save images and point cloud data from a rosbag file. This example also shows how to prepare the data for lidar camera calibration.

Download the rosbag file using the `helperDownloadRosbag` helper function, defined at the end of this example.

```
path = helperDownloadRosbag;
```

Retrieve information from the bag file.

```
bag = rosbag(path);
```

Select image and point cloud messages from the rosbag and select a subset of messages from the file by using the appropriate topic names. You can filter the data by using timestamps as well. For more information, see the `select` (ROS Toolbox) function.

```
imageBag = select(bag, 'Topic', '/camera/image/compressed');
pcBag = select(bag, 'Topic', '/points');
```

Read all the messages.

```
imageMsgs = readMessages(imageBag);
pcMsgs = readMessages(pcBag);
```

To prepare data for lidar camera calibration, the data across both the sensors must be time-synchronized. Create `timeseries` (ROS Toolbox) objects for the selected topics and extract the timestamps.

```
ts1 = timeseries(imageBag);
ts2 = timeseries(pcBag);
t1 = ts1.Time;
t2 = ts2.Time;
```

For accurate calibration, images and point clouds must be captured with the same timestamps. Match the corresponding data from both the sensors according to their timestamps. To account for uncertainty, use a margin of 0.1 seconds.

```
k = 1;
if size(t2,1) > size(t1,1)
    for i = 1:size(t1,1)
        [val,indx] = min(abs(t1(i) - t2));
        if val <= 0.1
            idx(k,:) = [i indx];
            k = k + 1;
        end
    end
else
    for i = 1:size(t2,1)
        [val,indx] = min(abs(t2(i) - t1));
        if val <= 0.1
            idx(k,:) = [indx i];
            k = k + 1;
        end
    end
end
```

Create directories to save the valid images and point clouds.

```
pcFilePath = fullfile(tempdir, 'PointClouds');
imageFilePath = fullfile(tempdir, 'Images');
if ~exist(imageFilePath, 'dir')
    mkdir(imageFilePath);
end
if ~exist(pcFilePath, 'dir')
    mkdir(pcFilePath);
end
```

Extract the images and point clouds. Name and save the files in their respective folders. Save corresponding image and point clouds under the same number.

```
for i = 1:length(idx)
    I = readImage(imageMsgs{idx(i,1)});
    pc = pointCloud(readXYZ(pcMsgs{idx(i,2)}));
    n_strPadded = sprintf('%04d', i);
    pcFileName = strcat(pcFilePath, '/', n_strPadded, '.pcd');
    imageFileName = strcat(imageFilePath, '/', n_strPadded, '.png');
    imwrite(I, imageFileName);
    pcwrite(pc, pcFileName);
end
```

Launch the Lidar Camera Calibrator app and use the interface to load the data into the app. You can also load the data and launch the app from the MATLAB® command line.

```
checkerSize = 81; %millimeters
padding = [0 0 0 0];
lidarCameraCalibrator(imageFilePath, pcFilePath, checkerSize, padding)
```

### Supporting Function

```
function rosbagFile = helperDownloadRosbag()
% Download the data set from the given URL.
rosbagZipFile = matlab.internal.examples.downloadSupportFile( ...
    'lidar', 'data/lccSample.zip');
[outputFolder, ~, ~] = fileparts(rosbagZipFile);
rosbagFile = fullfile(outputFolder, 'lccSample.bag');
if ~exist(rosbagFile, 'file')
    unzip(rosbagZipFile, outputFolder);
end
end
```

## Read, Process, and Write Lidar Point Cloud Data

This example shows how to read a point cloud into the workspace, select a desired set of points, and then write the selected points to a point cloud file format.

### Step 1: Read and Display Point Cloud

Read data from a .las file into the workspace by using the `lasFileReader` function. Display the properties stored in the output `lasFileReader` object.

```
fileName = fullfile(toolboxdir("lidar"), "lidardata", "las", "aerialLidarData.laz");
lasReader = lasFileReader(fileName)
```

```
lasReader =
```

```
  lasFileReader with properties:
```

```

        FileName: 'B:\matlab\toolbox\lidar\lidardata\las\aerialLidarData.laz'
          Count: 1018047
        LasVersion: '1.0'
        XLimits: [4.2975e+05 4.3015e+05]
        YLimits: [3.6798e+06 3.6801e+06]
        ZLimits: [72.7900 125.8200]
    GPSTimeLimits: [3.3355e+05 sec  3.3443e+05 sec]
      NumReturns: 4
      NumClasses: 10
  SystemIdentifier: 'LAStools (c) by rapidlasso GmbH'
  GeneratingSoftware: 'TerraScan + OT'
  FileCreationDate: 28-Apr-2020
  FileSourceID: 0
  ProjectID: '0-0-0-00000000'
  PointDataFormat: 1
  ClassificationInfo: [6x3 table]
  LaserReturnInfo: [4x2 table]
  VariableLengthRecords: [3x3 table]
```

Read the point cloud from the .las file.

```
ptCloud = readPointCloud(lasReader);
```

Display the point cloud.

```
fig = figure(Position=[0 0 800 400]);
hPanel = uipanel(fig);
hPlot = axes(hPanel);
pcshow(ptCloud.Location, Parent=hPlot)
```

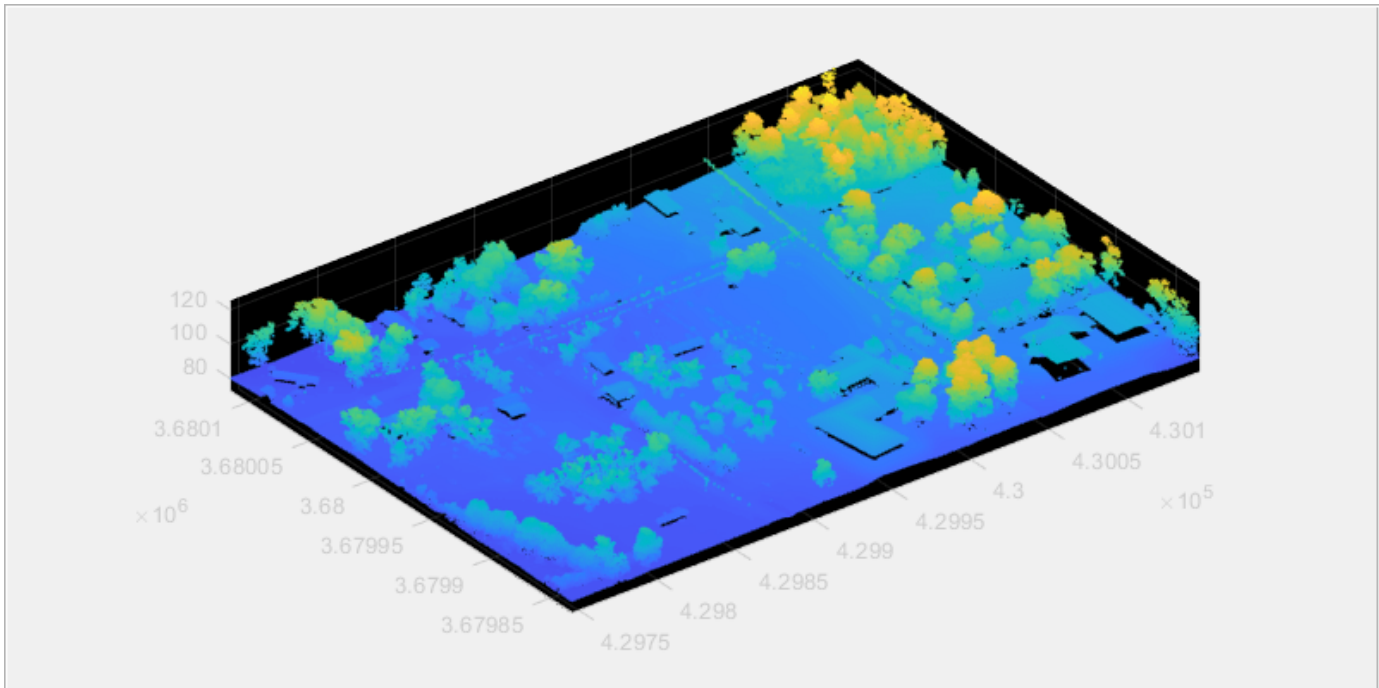

## Step 2: Select Desired Set of Points

You can select a desired set of points in the input point cloud by specifying the classification value for the object classes and indices of the points within a region-of-interest (ROI).

### Select points by specifying classification value

- To select the points by specifying the classification value, read information about the object classes in the input point cloud by using the `ClassificationInfo` property of the `lasFileReader` object.

```
disp(lasReader.ClassificationInfo)
```

Classification Value	Class Name	Number of Points by Class
1	"Unclassified"	114842
2	"Ground"	646632
4	"Medium Vegetation"	210101
6	"Building"	45699
8	"Reserved(8)"	751
9	"Water"	22

- Specify the classification value for the object class to read from the input point cloud by using the `readPointCloud` function. To read the points corresponding to medium vegetation region, set the value for `Classification` name-value argument to 4.

```
ptCloudB = readPointCloud(lasReader,Classification=4);
```

Display the point cloud.

```
fig1 = figure(Position=[0 0 800 400]);
hPanel1 = uipanel(fig1);
```



```
hPlot1 = axes(hPanel1);
pcshow(ptCloudB.Location,Parent=hPlot1)
```

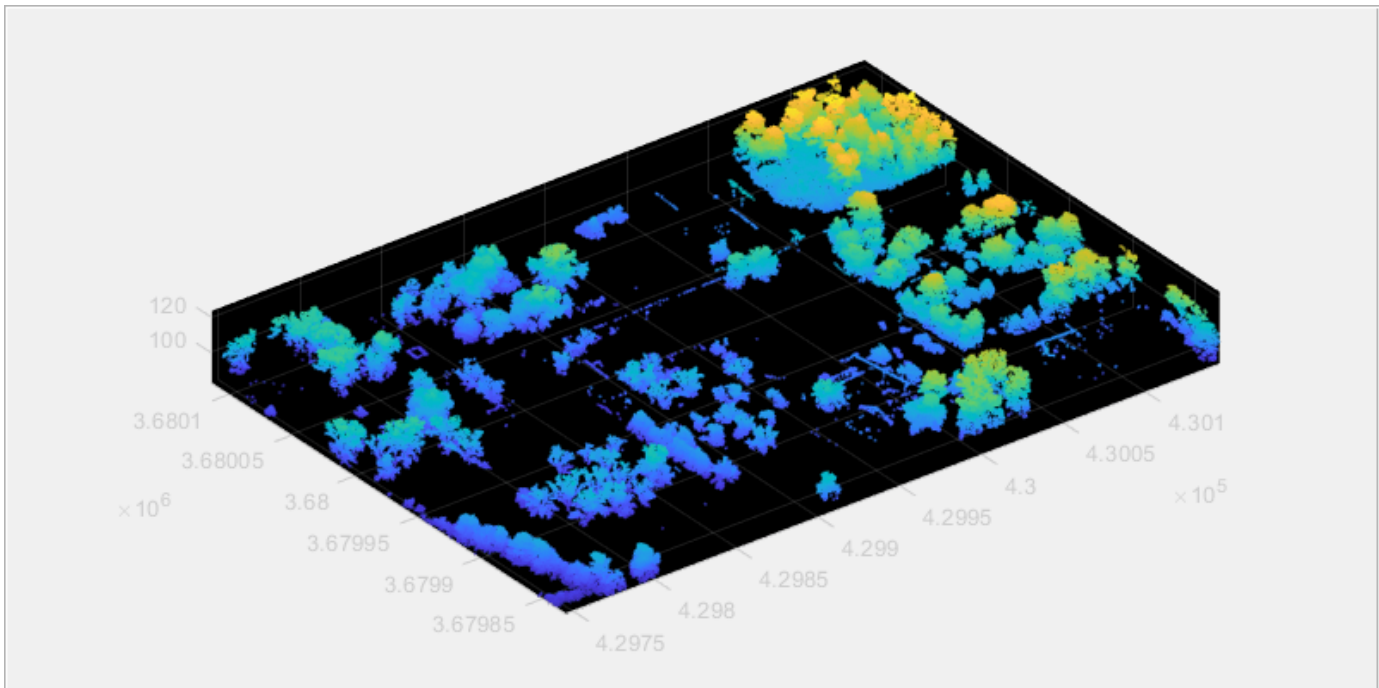

### Select points by specifying indices

Define a cuboid ROI within the range of the  $x$ ,  $y$  and  $z$  coordinates of the input point cloud.

```
roi = [lasReader.XLimits(1)+200, lasReader.XLimits(2), ...
      lasReader.YLimits(1), lasReader.YLimits(2), lasReader.ZLimits(1), lasReader.ZLimits(2)];
```

Find the indices of the points that lie within the cuboid ROI.

```
indices = findPointsInROI(ptCloudB,roi);
```

Select the points that lie within the cuboid ROI and store as a point cloud object.

```
ptCloudC = select(ptCloudB,indices);
```

Display the point cloud.

```
fig2 = figure(Position=[0 0 800 400]);
hPanel2 = uipanel(fig2);
hPlot2 = axes(hPanel2);
pcshow(ptCloudC.Location,Parent=hPlot2)
```

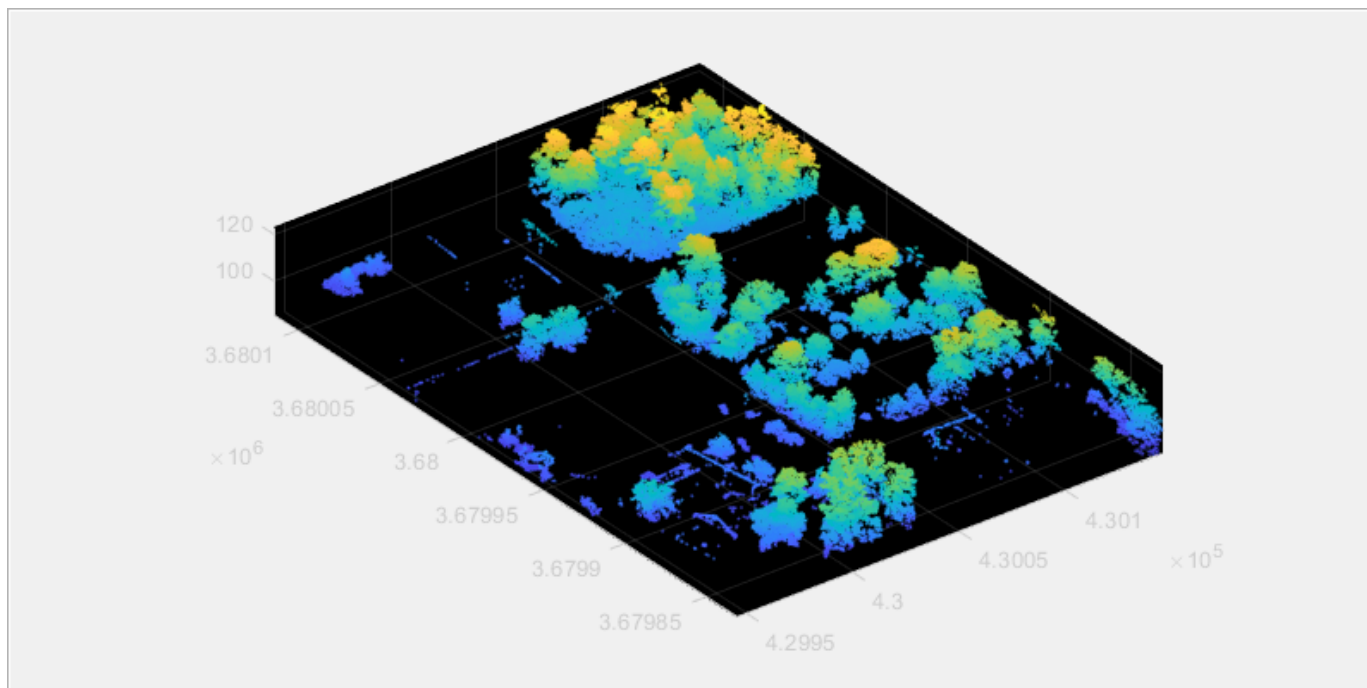

### Step 3: Write Selected Points to .las File format

Specify the name for the .las file and create a `lasFileWriter` object.

```
newfileName = "aerialvegetation.las";
lasWriter = lasFileWriter(newfileName);
```

Write the selected points to the .las file by using the `writePointCloud` function. The function creates the new file in the current working directory.

```
writePointCloud(lasWriter,ptCloudC);
```

### Step 4: Check Properties of the Newly Written File

```
newlasReader = lasFileReader(newfileName)
```

```
newlasReader =
```

```
lasFileReader with properties:
```

```

    FileName: 'C:\TEMP\Bdoc22a_1891349_13144\ibC86E06\20\tpae00cla1\lidar-ex0473765
      Count: 116598
    LasVersion: '1.2'
      XLimits: [4.2995e+05 4.3015e+05]
      YLimits: [3.6798e+06 3.6801e+06]
      ZLimits: [84.9500 123.1100]
    GPSTimeLimits: [0 sec 0 sec]
      NumReturns: 1
      NumClasses: 1
    SystemIdentifier: 'MATLAB'
    GeneratingSoftware: 'LASzip DLL 3.4 r1 (190411)'
    FileCreationDate: 25-Feb-2022
    FileSourceID: 0
    ProjectID: '0-0-0-00000000'
```

```
PointDataFormat: 3
ClassificationInfo: [1x3 table]
LaserReturnInfo: [1x2 table]
VariableLengthRecords: [0x3 table]
```

### **See Also**

[lasFileReader](#) | [pcshow](#) | [readPointCloud](#) | [findPointsInROI](#) | [pointCloud](#) | [select](#)

## Extract Ground Points and Non-Ground Points From Lidar Data

Read lidar data from a PCAP file by using the `velodyneFileReader` function.

```
veloReader = velodyneFileReader("lidarData_ConstructionRoad.pcap", "HDL32E");
```

Specify a time interval to extract a set of lidar data frames from the input lidar data.

```
veloReader.CurrentTime = veloReader.StartTime + seconds(5);
StopTime = veloReader.StartTime + seconds(20);
```

Configure the figure window to display the input lidar data frames and the extracted ground points by using the `pcplayer` function.

```
fig = figure(Position=[0 0 800 600]);

xlimits = [-30 30];
ylimits = [-30 30];
zlimits = [-10 20];
hPanel = uipanel(fig,Position=[0 0.5 1 0.5]);
hPlot = axes(hPanel);
player = pcplayer(xlimits,ylimits,zlimits,Parent=hPlot);

hPanel_groundData = uipanel(fig,Position=[0 0 0.5 0.5]);
hPlot_groundData = axes(hPanel_groundData);
player_groundData = pcplayer(xlimits,ylimits,zlimits,Parent=hPlot_groundData);

hPanel_nongroundData = uipanel(fig,Position=[0.5 0 0.5 0.5]);
hPlot_nongroundData = axes(hPanel_nongroundData);
player_nongroundData = pcplayer(xlimits,ylimits,zlimits,Parent=hPlot_nongroundData);
```

Read the lidar data frames and extract the ground points in the lidar data by using the `segmentGroundFromLidarData` function. Then, use the indices of the extracted ground points to segment the non-ground points from the frame.

```
while (hasFrame(veloReader) && veloReader.CurrentTime < StopTime)
    % Read a lidar data frame
    ptCloud = readFrame(veloReader);

    % Extract ground points from lidar data frame
    groundPtsIdx = segmentGroundFromLidarData(ptCloud);
    ptCloudGround = select(ptCloud,groundPtsIdx,OutputSize="full");

    % Extract non-ground points from lidar data frame
    ptCloudNonGround = select(ptCloud,~groundPtsIdx,OutputSize="full");

    % Display the input lidar data and the extracted points
    view(player,ptCloud)
    title(hPlot,"Input Lidar Data")
    view(player_groundData,ptCloudGround)
    title(hPlot_groundData,"Extracted Ground Points")
    view(player_nongroundData,ptCloudNonGround)
    title(hPlot_nongroundData,"Extracted Non-Ground Points")
    colormap(autumn)
    pause(0.01);
end
```

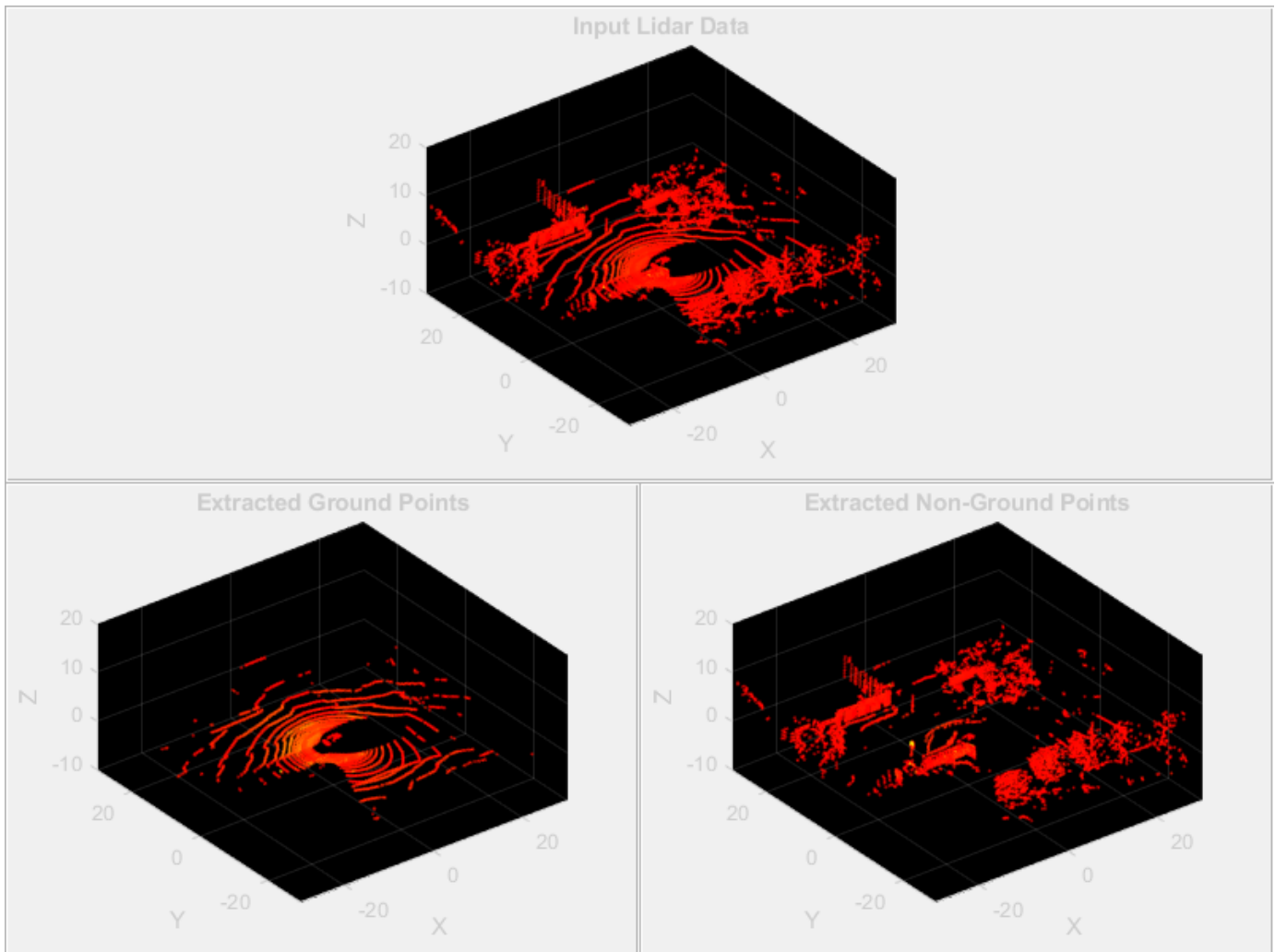

**See Also**

`select | segmentGroundFromLidarData | pcplayer`

